

# Worm Gear Sets

## 2" - 48" Center Distances



# Delroyd Worm Gear Sets • 2" - 48" Center Distance

## Contents

Engineering information .....	1
Application Data Form .....	5
Rating tables .....	6
Worm and gear data .....	31
Single - and double - extended worm assemblies .....	43
Gear assemblies.....	50
Gear shaft assemblies .....	51
Shaft-mounted gear shaft assemblies.....	55
Helical attachment assemblies.....	58
Primary worm attachment assemblies .....	59
Recommendations and Precautions .....	60

## Standard Components

The lowest cost and shortest delivery schedules are normally achieved through the use of standard worm and gear sets described in this catalog.

In addition to using standard shaft center distances, ratios and bearing mounting parts, designs should also include standard bores, flanges, and bolt circles where possible. Since the use of non-standard hubs is not uncommon to the worm gear industry, Delroyd provides for this by having a flanged rim design available for mounting on any adaptable center.

## Casing Design

When designing the casing used in the Delroyd worm gear speed reducer line, consideration was given to the accepted need for ruggedness, together with the requirements of retaining the lubricant, supporting bearings, excluding dirt and moisture, and dissipating heat.

On most applications for which worm and gear sets are purchased, the size and configuration of the casings are determined by the general requirements of the machine into which the set will be installed. In these cases, the area for heat dissipation is usually much greater than that of the standard reducer. Thus, the resulting temperature rise will be maintained well within the accepted industry limit of 100° F over ambient, without any auxiliary cooling. Where a separate box is to be designed for the worm and gear set, the same approximate casing proportions as used in the standard Delroyd reducer can be followed, provided fan cooling or some other form of auxiliary cooling is available. When continuous operation without auxiliary cooling is anticipated, a corresponding increase in casing area will be required.

## Case Machining For Proper Backlash

In any type of gearing a certain amount of backlash is required for satisfactory operation. Clearance must be provided to accommodate an oil film and to allow for thermal expansion. The amount of backlash provided is not of particular importance

in most applications. Closer limits than required will result in unnecessary higher costs and should naturally be avoided. It is important, however, to recognize where minimum backlash may be required to insure proper equipment functioning. Close limits are most often specified for accuracy of index or timing. In other instances, it may be advantageous to specify minimum backlash for limiting the stress at the gear teeth caused by shock loading - such as a reverse overriding impact load.

Listed below are standard extreme allowable backlash limits for standard sets, measured by a "circular shake" movement at a radius equal to the gear pitch radius. In machining the housing the center distance should be held within the right hand column tolerance. Any change over this will provide increased backlash measurement.

## Extreme Allowable Backlash Limits For Standard Sets\*

Center Distance	Normal Circular Shake Backlash Assembled	Using Center Distance Case Bore Tolerance
2.000	.003/.013	+.002/-.000
2.500	.003/.013	+.002/-.000
3.000	.003/.013	+.002/-.000
3.500	.003/.013	+.002/-.000
4.000	.004/.014	+.002/-.000
5.000	.004/.014	+.003/-.000
6.000	.005/.015	+.003/-.000
7.000	.006/.018	+.003/-.000
8.000	.007/.020	+.003/-.000
9.000	.008/.021	+.003/-.000
10.000	.010/.023	+.003/-.000
12.000	.010/.026	+.003/-.000
14.000	.013/.031	+.003/-.000
17.000	.015/.036	+.003/-.000
20.000	.019/.043	+.005/-.000
21.837	.020/.045	+.005/-.000
24.000	.020/.045	+.005/-.000
27.000	.020/.045	+.005/-.000
30.000	.020/.045	+.005/-.000
36.000	.020/.045	+.005/-.000
42.000	.025/.052	+.005/-.000
48.000	.025/.052	+.005/-.000

\*All dimensions in inches.

## Ratings

Ratings are given on pages 6-30 Refer to Delroyd catalogs 8804 and 7000 for complete selection procedure.

## Worm Bearing Fits And Adjustments

Dimensions, "MC", "MD", "MG" and "MH" (2" through 7" sizes) on pages 46 and 47 illustrate case bore dimensions for designer use in specifying correct component fit. Dimension "MH" represents the bearing manufacturer's recommended bore tolerance and dimension "MG" the bearing clearance bore. The same bores are used on both sides of the assembly. Bearing endplay should be adjusted to the following by use of shims at the bearing covers:

2" through 4" size .003 to .007"

5" through 7" size .006 to .010"

Housing bore dimensions on pages 40 through 52 (8" through 48" sizes) again represent recommended case machining tolerances. Dimension "MH" (8" through 12" sizes) is the thrust bearing manufacturer's recommended fit and the proper radial bearing housing case bore. Sizes 14" through 20" use a tapered roller radial bearing housing mounted in case bore dimension "MH". Sizes 21.837" through 48" use tapered roller bearings mounted directly in case housing bores "MH" and "MN". Worm thrust bearings with spacers are not adjustable and the bearing retainer should be pulled up tight to assure clamping of the cups and cup spacer. Proper end-play has been designed into the bearing spacer. No adjustment is required on the spherical or tapered roller bearings on the 8" through 48" sizes.

## Location Of Contact

Provision for adjustment of the gearing at assembly cannot be overlooked. The worm, having threads that are continuous in form, is not critical in regard to endwise location. The gear, however, must be precisely located in an axial position. In most assemblies the accumulation of tolerances on the dimensions of housings, shafts, bearings and gear makes it impractical to control the location of the gear by accuracy of machining alone. Correct positioning is normally achieved by shimming the gear at assembly.

All gears are produced to allow for deflection and to provide an entry gap for lubricant on the "entering side" of the gear teeth. Therefore, contact on the driving face of the worm gear tooth is required on the "leaving side" as shown in the top figure. Contact should be checked after the worm and gear have been installed by coating the threads of the worm with Prussian blue and turning gears in mesh by hand.

The contact surface can easily be shifted by changing shims at the opposite end of the gear shaft to move the gear to the right or left of the worm. In doing this, once bearing adjustment is made, shims should not be added or removed simply moved from under one cover to the other. When assembling a worm gear which has to run in both directions of rotation, it is necessary to consider both driving faces of the teeth and to aim at contact as shown in the bottom figure. Note that both faces have a leaving side contact in relation to the corresponding direction of rotation of the worm. This is an inherent feature of Delroyd worm gearing as the worm deflects under load, contact moves toward the center of the gear tooth but still maintains some gap for lubricant on the entering side.

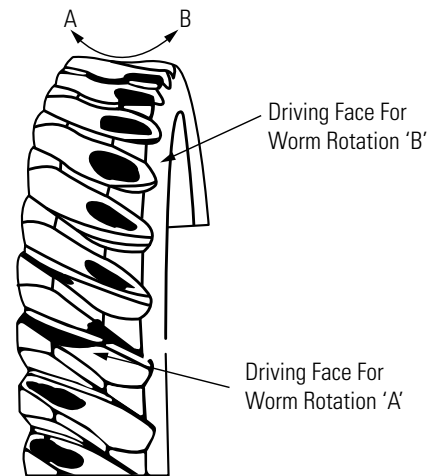
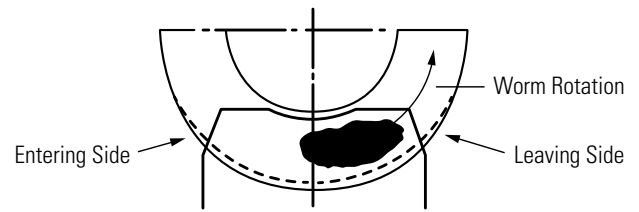

## Lubrication

Worm gear performance depends on the ability of the lubricant to reduce friction on, and carry heat from, the working surfaces. Recommended lubricants are those meeting requirements out-lined in Table #8, American Gear Manufacturers Association Specification #250.04, for cylindrical worm gearing. In the usual lubrication system, oil contained within the housing is directed by splash to the bearings and to the zone of tooth and thread contact. Natural splash can be augmented by flingers, scrapers and cups attached to the gear. Channels or ribs can be placed inside the housing to help direct oil to bearings. For splash lubrication the recommended lubricant levels are (1) worm-below-gear: level at center of worm; (2) worm-above-gear: level a 1/6 of gear diameter; and (3) worm-beside-gear: level at center of worm and gear. To avoid excessive oil churning, pressure lubrication is advisable where speeds are high. This method is also advisable for worm-mover-gear arrangements operation at speeds too slow to assure satisfactory lubrication. With this system an oil cooler in the pipeline can be used to good advantage.

# Engineering Information

## BEARING SELECTION

Careful consideration should be given to selection of bearings in order to locate adequately the gearing, and support the loads involved. A procedure for calculating bearing loads is presented on this page. The use of standards is recommended wherever design considerations permit.

## HOW TO CALCULATE BEARING LOADS

Friction Angle  $\phi$

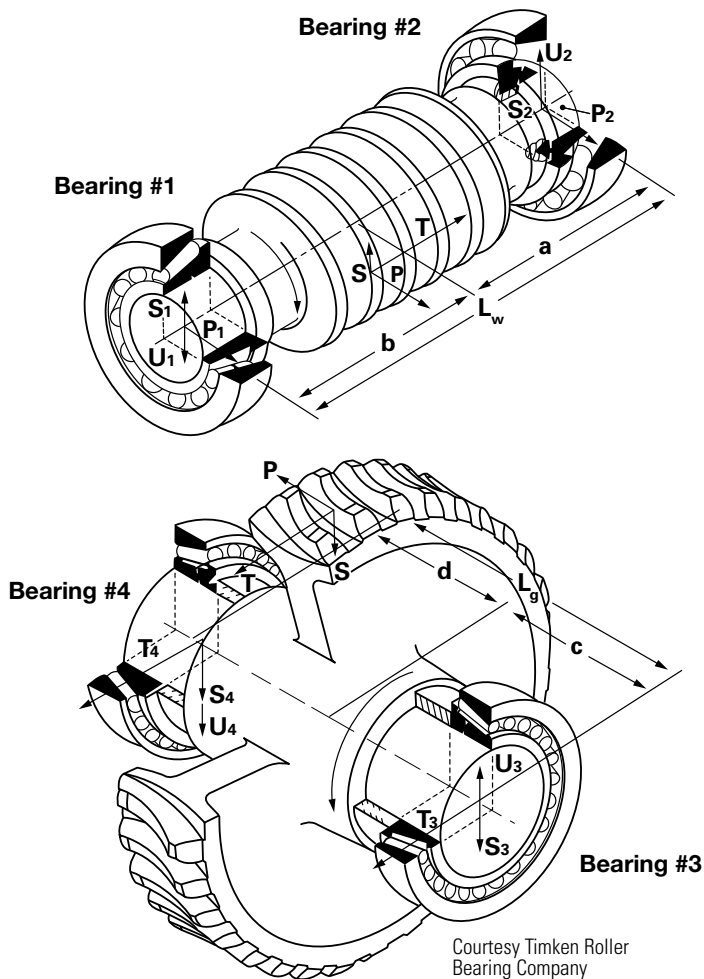
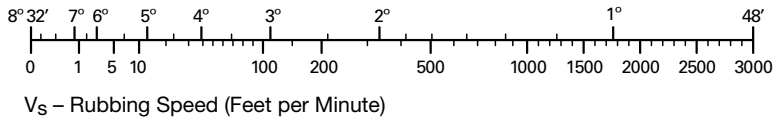

## GEARS

Integral gear and hub assemblies from standard Delroyd reducers are available as shown on page 53. This tabulation also shows flanged rim designs, size 3 1/2" center distance and larger, suitable for bolting to any adaptable center. Flanged rims fit the center in the counterbore only and a shrink fit is recommended where the gear is to transmit rated loads. This is necessary due to the differential rate of expansion between bronze and the center material, and insures positive location of the rim at maximum operating temperature. The flanged rim locating dimension is shown on page 53 as dimension "K". Also listed is the hub outside diameter "U" necessary to provide a recommended ASA Class FN-2 shrink fit. Assembly can easily be facilitated by heating the rim to about 200°F. This will cause sufficient expansion to permit center insertion for bolt hole alignment. Lightly loaded applications, where operating temperatures stay reasonably under the normal 180° F range, can use a free fit. The interference fit should also be avoided on applications involving less than standard backlash.

### Principal forces and bearing loads in a worm and gear set.

$P$	$= Q/WPR$
$S$	$= P \tan NPA/\sin (LA+ \phi)$
$T$	$= P / \tan (LA+ \phi)$
$V_s$	$= .262 (WPD) (RPM) / \cos LA$

where

WPD	is	pitch diameter of worm, inches
WPR	is	pitch radius of worm, inches
GPR	is	pitch radius of gear, inches
LA	is	lead angle of worm, degrees
P	is	tangential force of worm, pounds
Q	is	torque input to worm, inch pounds
S	is	separating force, pounds
T	is	axial thrust of worm, pounds
NPA	is	normal pressure angle, degrees*
$\phi$	is	friction angle for worm driving, degrees
RPM	is	worm speed, RPM
$V_s$	is	rubbing speed, feet per minute

\*20° for C.D. 2.000", 3.500", and 14.000"

through 48.000".

22 1/2° for C.D. 3.000", and 4.000" through 12.000".

## Bearing Loads

Resulting from	Bearing #1	Bearing #2	Bearing #3	Bearing #4
P	$P(a)/L_w = P_1$	$P(b)/L_w = P_2$	$P(GPR)/L_g = U_3$	$P(GPR) / L_g = U_4$
S	$S(a)/L_w = S_1$	$S(b)/L_w = S_2$	$S(d)/L_g = S_3$	$S(c)/L_g = S_4$
T	$T(WPR)/L_w = U_1$	$T(WPR)/L_w = U_2$	$T(d)/L_g = T_3$	$T(c)/L_g = T_4$
Radial Load	$\sqrt{P_1^2 + (S_1 - U_1)^2}$ =R1	$\sqrt{P_2^2 + (S_2 + U_2)^2}$ =R2	$\sqrt{T_3^2 + (U_3 - S_3)^2}$ =R3	$\sqrt{T_4^2 + (S_4 + U_4)^2}$ =R4
Thrust Load		T		P



## Approximate WR<sup>2</sup> Values

Assuming uniform acceleration (or deceleration), the motor torque required to accelerate - or the brake torque required to decelerate - in a given time can be determined by the following:

$$T = \frac{WR_{ws}^2 \times \Delta N}{3690t}$$

where

$$T = \text{Torque in inch pounds}$$

$$WR_{ws}^2 = \text{lb-in}^2$$

$$\Delta N = \text{RPM change}$$

$$t = \text{Time in seconds}$$

Listed in the table are approximate WR<sup>2</sup> values for standard single extended worm gear assemblies and standard low speed shaft assemblies for sets shown in this catalog.

$$WR_{ws}^2 = \frac{WR_{LSS}^2 \times WR_{DL}^2}{(\text{ratio})^2} + WR_{WA}^2 + WR_M^2$$

where

$WR_{ws}^2$  is  $WR^2$  of the system with respect to input shaft

$WR_{LSS}^2$  is  $WR^2$  of the reducer low speed shaft assembly

$WR_{DL}^2$  is  $WR^2$  of the driven load

$WR_{WA}^2$  is  $WR^2$  of the worm assembly

$WR_M^2$  is  $WR^2$  of the motor

Center Distance	WR <sup>2</sup> Worm Assembly lb-in <sup>2</sup>	WR <sup>2</sup> Low Speed Shaft Assembly* lb-in <sup>2</sup>
2.500"	.36	10.0
3.000"	1.40	20.0
3.500"	1.58	53.0
4.000"	3.30	114
5.000"	8.52	265
6.000"	15.4	633
7.000"	16.3	1,220
8.000"	38.7	2,250
9.000"	55.3	4,020
10.000"	76.4	6,700
12.000"	151	17,300
14.000"	369	23,800
17.000"	513	66,300
20.000"	1,920	174,000
21.837"	2,150	215,000
24.000"	3,560	487,000
27.000"	6,510	566,000
30.000"	7,910	945,000
36.000"	10,600	2,140,000
42.000"	26,800	4,420,000
48.000"	31,700	8,030,000

\*Below 12" center distance, this value represents a complete gear and not just a flanged rim. For 12" and greater center distances, the  $WR_{LSS}^2$  consists of a flanged rim plus a gear center approximating the size of the gear center used in standard Delroyd units.

## Service Factors

Tables in this catalog provide mechanical ratings in terms of input horsepower and inch-pounds output torque. Mechanical ratings reflect gearing wear capacity. Values in the rating tables apply for continuous service, free from recurrent shock loading, and of total duration up to ten hours per day. Normal starting or momentary peak loads up to 300% of this rating are permissible for a maximum period of two seconds duration. The total number of 300% peak loads is limited to 25,000 over the life of the reducer. Use of service factors is necessary dependent on actual nature and duration of service. The terms specified in the service factor table "intermittent" and "occasional" refer to total operating time per day while the term "frequent starts and stops" refers to more than ten starts per hour.

## Service Factors

		Driven Machine AGMA Load Classification		
		Uniform	Moderate Shock	Heavy Shock
	Duration of Service	(Peak Load of 100% of Driver Hp.)	(Peak Load of 125% of Driver Hp.)	(Peak Load of 150% of Driver Hp.)
Prime Mover	occasional 1/2 hr/day	0.80	0.90	1.00
	intermittent 2 hr/day	0.90	1.00	1.25
	10 hr/day	1.00	1.25	1.50
	24 hr/day	1.25	1.50	1.75
Electric Motor	occasional 1/2 hr/day	0.90	1.00	1.25
	intermittent 2 hr/day	1.00	1.25	1.50
	10 hr/day	1.25	1.50	1.75
	24 hr/day	1.50	1.75	2.00
Multi-cylinder internal combustion engine	occasional 1/2 hr/day	1.00	1.25	1.50
	intermittent 2 hr/day	1.25	1.50	1.75
	10 hr/day	1.50	1.75	2.00
	24 hr/day	1.75	2.00	2.25
Single cylinder internal combustion engine	occasional 1/2 hr/day	1.00	1.25	1.50
	intermittent 2 hr/day	1.25	1.50	1.75
	10 hr/day	1.50	1.75	2.00
	24 hr/day	1.75	2.00	2.25

FOR FREQUENT STARTS AND STOPS  
(more than 10 per hour)

Electric motor	occasional 1/2 hr/day	0.90	1.00	1.25
	intermittent 2 hr/day	1.00	1.25	1.50
	10 hr/day	1.25	1.50	1.75
	24 hr/day	1.50	1.75	2.00

# Worm Gear Set Application Data Sheet

\* 1. Quantity \_\_\_\_\_  
Delivery \_\_\_\_\_

\* 2. Will This job repeat \_\_\_\_\_

\* 3. Center Distance \_\_\_\_\_

\* 4. Ratio  
A. Exact \_\_\_\_\_  
B. +/- 3% \_\_\_\_\_  
C. Other \_\_\_\_\_

\* 5. Threadform  
A. Use Delroyd Standard \_\_\_\_\_  
B. Duplicate exactly \_\_\_\_\_ (sample required)

\* 6. Backlash  
A. Delroyd Standard \_\_\_\_\_  
B. Less than standard \_\_\_\_\_  
(specify limits) \_\_\_\_\_ / \_\_\_\_\_

7. Output Torque \_\_\_\_\_ inch pounds, service factor \_\_\_\_\_  
A. AGMA Load Class \_\_\_\_\_ Uniform (Peak Load of 100% of Driven Hp.)  
\_\_\_\_\_ Moderate Shock (Peak Load of 125% of Driven Hp.)  
\_\_\_\_\_ Heavy Shock (Peak Load of 150% of Driven Hp.)  
B. Hours per day operation \_\_\_\_\_  
C. Starts and Stops per hour \_\_\_\_\_ day \_\_\_\_\_

\* 8. Driving Unit Information  
A. Driver \_\_\_\_\_ (Electric Motor, etc.)  
HP \_\_\_\_\_ at \_\_\_\_\_ RPM Brake Size \_\_\_\_\_  
Starting Torque \_\_\_\_\_ % Nema \_\_\_\_\_  
Motor Frame \_\_\_\_\_  
Voltage \_\_\_\_\_ PH \_\_\_\_\_ HZ \_\_\_\_\_ DC \_\_\_\_\_

\* 9. Load Information  
A. What is this gear set driving? \_\_\_\_\_

10. Noise requirements? \_\_\_\_\_

11. Oil being used for existing set? \_\_\_\_\_

12. Duplicate performance \_\_\_\_\_  
Improved performance \_\_\_\_\_

13. Gear rim mounting holes  
A. \_\_\_\_\_ Customer to supply at assembly  
B. \_\_\_\_\_ Delroyd to supply (possible tooling charge)

14. Special Specifications  
A. Worm Shaft Material \_\_\_\_\_  
B. Heat Treating Process \_\_\_\_\_  
C. Thread Lead Accuracy \_\_\_\_\_  
D. Gear Material \_\_\_\_\_  
E. Gear Tooth Spacing Accuracy \_\_\_\_\_  
F. Testing Requirements \_\_\_\_\_  
G. Dimensional Tolerances \_\_\_\_\_  
I. Other \_\_\_\_\_

15. How long did the existing gear set operate? \_\_\_\_\_

16. Company Name \_\_\_\_\_  
Address \_\_\_\_\_  
City \_\_\_\_\_  
Phone Number \_\_\_\_\_

Your Name \_\_\_\_\_  
Date \_\_\_\_\_  
State \_\_\_\_\_ Zip \_\_\_\_\_  
Fax Number \_\_\_\_\_

\*Minimum Required Information

DELROYD\* is represented by an extensive network of distributors throughout North America. Please call toll free, 1-800-432-0121 for the name of the nearest distributor.



**Delroyd Worm Gear**  
PO Box 1032  
Niagara Falls, NY USA 14302-1032  
tel: 716.298-4100  
fax: 716.298-4101

# Horsepower and Torque Ratings

## Center Distance 2.000"

Ratio	Worm Speed RPM	1750	1450	1150	865	680	575	450	300	100
5-1/6	Input HP	2.77	2.48	2.20	1.82	1.51	1.33	1.09	.765	.278
	Output Torque	465	503	560	610	645	662	690	720	757
7-1/4	Input HP	2.27	2.04	1.77	1.45	1.21	1.06	.867	.589	.213
	Output Torque	525	568	620	673	705	725	750	755	790
9-2/3	Input HP	1.74	1.56	1.34	1.08	.894	.778	.624	.440	.157
	Output Torque	525	567	611	650	680	693	715	740	775
12-1 /2	Input HP	1.52	1.38	1.21	1.01	.850	.740	.610	.430	.170
	Output Torque	598	651	708	768	809	833	863	900	952
15-1 /2	Input HP	1.32	1.18	1.02	.828	.687	.603	.487	.338	.125
	Output Torque	603	549	696	744	780	800	820	847	885
20-1/2	Input HP	1.08	.982	.821	.667	.556	.484	.394	.278	.102
	Output Torque	623	657	708	755	790	806	830	860	895
25	Input HP	.950	.861	.751	.623	.527	.445	.384	.272	.099
	Output Torque	623	680	740	798	840	860	890	925	970
30	Input HP	.806	.718	.622	.515	.429	.376	.307	.218	.082
	Output Torque	620	670	720	773	808	827	846	876	920
38	Input HP	.680	.600	.520	.440	.371	.321	.260	.191	.071
	Output Torque	626	673	724	775	810	831	857	888	933
40	Input HP	.654	.586	.506	417	.350	.308	.252	.180	.069
	Output Torque	625	675	723	773	805	830	848	878	916
46	Input HP	.542	.491	.432	.361	.318	.271	.231	.170	.062
	Output Torque	614	660	709	759	794	814	838	869	912
50	Input HP	.522	.462	.401	.328	.303	.240	.197	.140	.054
	Output Torque	580	620	668	707	735	750	765	787	825
54	Input HP	.471	.425	.386	.320	.272	.232	.186	.136	.052
	Output Torque	593	636	683	730	762	781	804	833	873
60	Input HP	.434	.385	.330	.271	.226	.197	.162	.116	.044
	Output Torque	550	586	622	660	686	698	715	734	753
70	Input HP	.348	.318	.269	.222	.185	.162	.138	.094	.036
	Output Torque	500	533	565	597	620	630	644	650	688

Ratings based on 1.0 service factor. For AGMA recommended practice on service factors, see page 4.

# Horsepower and Torque Ratings

## Center Distance 2.500"

Ratio	Worm Speed RPM	1750	1450	1150	865	680	575	450	300	100
5-1/6	Input HP	4.14	3.79	3.37	2.81	2.37	2.10	1.72	1.22	.446
	Output Torque	709	781	872	962	1030	1070	1110	1170	1250
7-1/4	Input HP	3.59	3.26	2.85	2.35	1.97	1.72	1.41	.990	.359
	Output Torque	856	936	1030	1120	1180	1220	1270	1320	1400
9-2/3	Input HP	2.88	2.61	2.27	1.87	1.55	1.36	1.10	.781	.283
	Output Torque	898	977	1070	1160	1210	1250	1290	1340	1410
12-2/3	Input HP	2.80	2.52	2.20	1.81	1.50	1.30	1.01	.771	.28
	Output Torque	1086	1185	1293	1404	1481	1527	1584	1654	1753
15-1/2	Input HP	2.08	1.87	1.62	1.33	1.11	.968	.792	.554	.205
	Output Torque	993	1080	1170	1260	1320	1350	1400	1450	1520
20-1/2	Input HP	1.66	1.48	1.28	1.05	.873	.766	.617	.436	.160
	Output Torque	1010	1090	1170	1260	1320	1350	1380	1440	1500
25	Input HP	1.46	1.33	1.17	.980	.824	.727	.598	.426	.160
	Output Torque	1040	1140	1240	1350	1420	1470	1520	1580	1660
30	Input HP	1.25	1.13	.994	.812	.684	.600	.492	.350	.133
	Output Torque	1040	1120	1230	1310	1380	1410	1450	1510	1590
40	Input HP	.972	.874	.748	.626	.521	.462	.378	.270	.103
	Output Torque	1020	1100	1180	1270	1310	1360	1400	1440	1510
50	Input HP	.797	.715	.623	.515	.435	.381	.313	.225	.087
	Output Torque	978	1050	1140	1210	1270	1300	1340	1390	1450
60	Input HP	.668	.601	.525	.435	.368	.323	.265	.191	.075
	Output Torque	929	1000	1080	1160	1210	1240	1270	1310	1380
70	Input HP	.551	.494	.431	.357	.302	.266	.219	.158	.062
	Output Torque	849	912	982	1050	1100	1120	1150	1190	1250

Ratings based on 1.0 service factor. For AGMA recommended practice on service factors, see page 4.



# Horsepower and Torque Ratings

## Center Distance 3.000"

Ratio	Worm Speed RPM	1750	1450	1150	865	680	575	450	300	100
5-1/6	Input HP	7.62	7.06	6.33	5.39	4.62	4.09	3.38	2.42	.900
	Output Torque	1320	1470	1660	1870	2020	2110	2200	2340	2530
7-1/4	Input HP	6.40	5.89	5.24	4.39	3.73	3.29	2.71	1.92	.720
	Output Torque	1540	1710	1900	2100	2260	2340	2450	2580	2750
9-2/3	Input HP	5.39	4.91	4.33	3.63	3.07	2.69	2.22	1.57	.576
	Output Torque	1700	1870	2030	2280	2440	2510	2620	2740	2920
15-1/2	Input HP	3.92	3.59	3.20	2.67	2.26	2.00	1.60	1.18	.439
	Output Torque	1900	2090	2330	2550	2720	2810	2920	3070	3260
20-1/2	Input HP	3.07	2.78	2.43	2.01	1.70	1.50	1.22	.860	.324
	Output Torque	1920	2080	2300	2480	2620	2700	2800	2920	3080
24-1/2	Input HP	2.71	2.45	2.17	1.81	1.53	1.35	1.11	.792	.294
	Output Torque	1970	2150	2360	2580	2720	2790	2910	3040	3220
30	Input HP	2.31	2.13	1.90	1.61	1.38	1.22	1.02	.731	.283
	Output Torque	1970	2170	2400	2650	2820	2910	3050	3180	3390
40	Input HP	1.79	1.63	1.44	1.21	1.03	.911	.746	.550	.203
	Output Torque	1930	2110	2310	2520	2650	2740	2840	2960	3110
50	Input HP	1.46	1.34	1.19	.991	.847	.749	.624	.449	1.73
	Output Torque	1870	2040	2230	2430	2560	2640	2730	2860	3010
60	Input HP	1.19	1.09	.943	.799	.663	.599	.495	.359	.143
	Output Torque	1750	1910	2070	2230	2290	2410	2490	2590	2710
70	Input HP	1.02	9.26	.821	.702	.596	.534	.450	.327	.132
	Output Torque	1640	1790	1960	2130	2250	2320	2400	2500	2640

Ratings based on 1.0 service factor. For AGMA recommended practice on service factors, see page 4.

# Horsepower and Torque Ratings

## Center Distance 3.500"

Ratio	Worm Speed RPM	1750	1450	1150	865	680	575	450	300	100
5-1/6	Input HP	10.8	10.0	9.12	8.10	6.87	6.18	5.16	3.75	1.41
	Output Torque	1880	2090	2400	2820	3020	3200	3390	3650	3990
7-1/4	Input HP	8.72	8.10	7.29	6.24	5.36	4.76	3.95	2.83	1.06
	Output Torque	2100	2360	2600	3020	3270	3410	3580	3810	4130
9-2/3	Input HP	7.64	7.11	6.42	5.52	4.75	4.25	3.54	2.54	.960
	Output Torque	2420	2710	3070	3480	3770	3960	4170	4430	4810
12-1/2	Input HP	6.35	5.97	5.39	4.61	3.94	3.52	2.92	2.15	.80
	Output Torque	2570	2900	3270	3660	3940	4110	4320	4590	4970
14-1/2	Input HP	5.68	5.39	4.95	4.27	3.69	3.30	2.73	2.04	.77
	Output Torque	2620	2980	3390	3840	4150	4340	4580	4890	5330
15-1/2	Input HP	5.48	5.15	4.61	3.94	3.40	3.03	2.53	1.82	.697
	Output Torque	2670	3010	3380	3820	4110	4300	4520	4790	5180
20-1/2	Input HP	4.48	4.05	3.63	3.08	2.64	2.35	1.96	1.40	.536
	Output Torque	2750	3060	3420	3810	4090	4250	4450	4700	5040
24-1/2	Input HP	3.82	3.53	3.16	2.72	2.33	2.07	1.73	1.25	.482
	Output Torque	2780	3100	3460	3890	4160	4320	4530	4790	5130
30	Input HP	3.24	3.03	2.75	2.38	2.07	1.86	1.57	1.15	.580
	Output Torque	2770	3100	3500	3960	4260	4460	4690	4980	5370
40	Input HP	2.55	2.39	2.16	1.86	1.62	1.46	1.22	.898	.358
	Output Torque	2750	3080	3450	3860	4170	4340	4550	4810	5170
50	Input HP	2.07	1.92	1.74	1.50	1.30	1.17	.986	.718	.287
	Output Torque	2660	2960	3300	3680	3940	4100	4290	4520	4820
60	Input HP	1.68	1.60	1.44	1.25	1.09	.973	.826	.604	.243
	Output Torque	2450	2800	3130	3480	3730	3850	4040	4250	4540
70	Input HP	1.43	1.32	1.20	1.04	.906	.806	.693	.508	.260
	Output Torque	2330	2580	2880	3190	3420	3550	3720	3910	4170

Ratings based on 1.0 service factor. For AGMA recommended practice on service factors, see page 4.

# Horsepower and Torque Ratings

## Center Distance 4.000"

Ratio	Worm Speed RPM	1750	1450	1150	865	680	575	450	300	100
5-1/6	Input HP	14.8	13.5	12.3	10.9	9.44	8.62	7.30	5.36	2.05
	Output Torque	2580	2830	3240	3800	4170	4480	4810	5230	5830
7-1/4	Input HP	11.7	10.8	9.83	8.52	7.39	6.64	5.54	4.03	1.52
	Output Torque	2820	3150	3600	4120	4520	4770	5050	5420	5920
9-2/3	Input HP	10.1	9.37	8.46	7.40	6.30	5.63	4.69	3.41	1.28
	Output Torque	3220	3610	4080	4720	5060	5320	5600	6040	6520
11-2/3	Input HP	8.77	8.35	7.63	6.57	5.61	5.01	4.21	3.01	1.18
	Output Torque	3340	3810	4345	4920	5330	5580	5900	6300	6880
12-2/3	Input HP	8.15	7.88	7.02	6.20	5.22	4.72	3.91	2.82	1.11
	Output Torque	3410	3880	4410	4990	5400	5660	5970	6370	6940
14-2/3	Input HP	7.45	6.99	6.20	5.25	4.51	4.08	3.40	2.45	.919
	Output Torque	3510	3940	4420	4940	5310	5530	5800	6150	6640
15-1/2	Input HP	7.22	6.74	6.06	5.22	4.50	4.01	3.33	2.42	.914
	Output Torque	3570	4010	4510	5120	5550	5790	6080	6500	7000
17-1/2	Input HP	6.51	6.15	5.61	4.79	4.12	3.62	3.08	2.23	.89
	Output Torque	3610	4080	4620	5190	5600	5840	6150	6540	7100
20-1/2	Input HP	5.74	5.32	4.76	4.07	3.50	3.11	2.59	1.86	.709
	Output Torque	3660	4080	4560	5120	5530	5750	6030	6370	6860
24-1/2	Input HP	4.91	4.54	4.06	3.45	2.96	2.62	2.19	1.57	.596
	Output Torque	3670	4080	4550	5070	5450	5640	5940	6250	6690
27-1/2	Input HP	4.43	4.28	3.85	3.28	2.94	2.54	2.15	1.53	.584
	Output Torque	3700	4160	4680	5230	5620	5850	6140	6510	7040
30	Input HP	4.23	3.96	3.58	3.09	2.69	2.41	2.03	1.48	.580
	Output Torque	3710	4160	4960	5290	5730	5990	6300	6710	7240
35	Input HP	3.65	3.45	3.18	2.78	2.47	2.19	1.86	1.31	.52
	Output Torque	3690	4170	4720	5300	5720	5960	6280	6670	7240
36	Input HP	3.58	3.40	3.12	2.70	2.30	2.10	1.81	1.30	.510
	Output Torque	3690	4170	4710	5304	5720	5970	6280	6680	7250
40	Input HP	3.31	3.08	2.78	2.39	2.08	1.86	1.57	1.14	.448
	Output Torque	3690	4120	4610	5170	5580	5790	6080	6430	6910
46	Input HP	2.90	2.78	2.60	2.29	1.92	1.79	1.51	1.15	.45
	Output Torque	3610	4080	4630	5210	5620	5870	6190	6580	7150
48	Input HP	2.77	2.64	2.39	2.07	1.82	1.61	1.41	1.05	.440
	Output Torque	3600	4040	4530	5050	5420	5640	5910	6260	6760
50	Input HP	2.65	2.45	2.20	1.88	1.62	1.35	1.22	.883	.345
	Output Torque	3550	3930	4380	4860	5200	5400	5640	5930	6300
60	Input HP	2.12	1.94	1.73	1.48	1.26	1.13	.941	.680	.266
	Output Torque	3310	3630	4010	4420	4700	4860	5050	5280	5600
70	Input HP	1.82	1.68	1.53	1.32	1.15	1.03	.870	.639	.258
	Output Torque	3100	3440	3860	4280	4590	4760	4960	5240	5600

Ratings based on 1.0 service factor. For AGMA recommended practice on service factors, see page 4.

# Horsepower and Torque Ratings

## Center Distance 5.000"

Ratio	Worm Speed RPM	1750	1450	1150	865	680	575	450	300	100
5-1/6	Input HP	23.8	21.8	19.5	17.4	15.7	14.3	12.4	9.32	3.65
	Output Torque	4180	4620	5170	6120	6930	7480	8200	9150	10500
7-1/4	Input HP	19.7	18.1	16.4	14.6	12.9	11.7	10.1	7.26	2.84
	Output Torque	4830	5330	6080	7130	7960	8500	9180	10000	11200
9-2/3	Input HP	16.6	15.4	13.9	12.3	10.8	9.85	8.37	6.08	2.33
	Output Torque	5360	5970	6770	7890	8780	9420	10100	10900	12000
11-2/3	Input HP	14.6	13.6	12.3	11.0	9.70	8.80	7.40	5.51	2.15
	Output Torque	5690	6330	7160	8370	9270	9830	10500	11400	12700
12 -2/3	Input HP	13.6	12.4	11.4	10.1	8.81	7.91	6.70	4.90	1.89
	Output Torque	5730	6200	7230	8370	9200	9710	10300	11200	12300
15-1/2	Input HP	11.6	10.9	9.95	8.63	7.59	6.74	5.65	4.12	1.57
	Output Torque	5830	6600	7570	8640	9610	10000	10600	11400	12400
18-1/2	Input HP	10.2	9.25	8.58	7.51	6.55	5.91	4.99	3.69	1.47
	Output Torque	6070	6620	7670	8820	9650	10200	10800	11600	12800
20-1/2	Input HP	9.28	8.57	7.87	6.88	6.00	5.42	4.56	3.36	1.30
	Output Torque	6000	6660	7650	8780	9620	10200	10800	11600	12700
24-1/2	Input HP	7.94	7.40	6.75	5.89	5.12	4.59	3.85	2.83	1.10
	Output Torque	6040	6750	7710	8820	9630	10100	10600	11400	12600
27-1/2	Input HP	7.22	6.73	6.18	5.40	4.74	4.22	3.61	2.70	1.06
	Output Torque	6170	6750	7780	8910	9720	10200	10800	11600	12700
29-1/2	Input HP	6.80	6.34	5.80	5.06	4.42	3.99	3.35	2.47	.966
	Output Torque	6070	6800	7760	8850	9680	10200	10800	11500	12600
36	Input HP	5.79	5.30	4.95	4.40	3.90	3.52	3.01	2.25	.92
	Output Torque	6190	6740	7810	8990	9850	10300	11000	11800	13100
40	Input HP	5.25	4.88	4.51	3.95	3.45	3.12	2.64	1.95	.778
	Output Torque	6010	6710	7670	8770	9570	10000	10600	11400	12400
48	Input HP	4.12	4.04	3.75	3.30	2.90	2.61	2.21	1.65	.69
	Output Torque	5760	6570	7490	8490	9200	9640	10100	10900	11800
50	Input HP	4.21	3.90	3.56	3.13	2.76	2.49	2.11	1.56	.626
	Output Torque	5800	6450	7280	8390	9130	9560	10100	10700	11700
60	Input HP	3.40	3.19	2.90	2.52	2.16	1.99	1.69	1.24	.501
	Output Torque	5440	6100	6870	7800	8440	8810	9250	9840	10600
70	Input HP	2.85	2.65	2.44	2.16	1.91	1.74	1.49	1.12	.465
	Output Torque	5000	5600	6350	7270	7920	8330	8800	9410	10300
100	Input HP	1.59	1.60	1.49	1.22	1.12	1.02	.91	.61	.31
	Output Torque	3570	4040	4570	5130	5540	5780	6090	6470	7020

Ratings based on 1.0 service factor. For AGMA recommended practice on service factors, see page 4.

# Horsepower and Torque Ratings

## Center Distance 6.000"

Ratio	Worm Speed RPM	1750	1450	1150	865	680	575	450	300	100
5-1/8	Input HP	34.8	31.7	28.3	25.2	22.9	21.0	18.3	14.0	5.66
	Output Torque	6090	6690	7490	8810	10200	11000	12100	13800	16100
7-2/5	Input HP	28.9	26.4	23.7	21.2	19.0	17.3	14.9	11.1	4.37
	Output Torque	7250	7980	9000	10700	12000	12900	14100	15600	17800
9-3/4	Input HP	24.0	21.9	19.8	17.7	15.5	14.2	12.2	9.00	3.49
	Output Torque	7870	8650	9830	11600	12800	13900	15000	16400	18400
11-2/3	Input HP	21.4	19.9	17.9	15.9	13.9	12.5	10.6	7.81	3.02
	Output Torque	8410	9370	10590	12400	13700	14500	15500	16900	18900
14-2/3	Input HP	18.0	16.4	15.0	13.4	11.8	10.7	9.09	6.55	2.61
	Output Torque	8660	9530	10900	12800	14300	15200	16300	17400	19800
20-1/2	Input HP	14.0	12.8	11.7	10.4	9.28	8.38	7.23	5.36	2.13
	Output Torque	9160	10000	11500	13400	15100	16000	17300	18800	21100
24-1/2	Input HP	11.9	10.9	10.0	8.86	7.87	7.11	6.07	4.53	1.78
	Output Torque	9180	10100	11600	13500	15000	15900	17000	18500	20400
29-1/2	Input HP	10.2	9.36	8.59	7.64	6.79	6.16	5.28	3.96	1.63
	Output Torque	9220	10200	11600	13500	15100	16000	17200	18700	20800
40	Input HP	7.83	7.15	6.65	5.91	5.27	4.79	4.13	3.11	1.26
	Output Torque	9150	10100	11600	13400	15000	15900	17000	18500	20500
45	Input HP	7.00	6.51	5.97	5.47	4.90	4.48	3.88	2.98	1.29
	Output Torque	9120	10100	11400	13500	15000	15900	17200	18700	21000
48	Input HP	6.44	6.04	5.62	5.01	4.51	4.09	3.50	2.70	1.19
	Output Torque	8990	10000	11300	13200	14600	15500	16600	18000	20100
50	Input HP	6.22	5.73	5.28	4.71	4.19	3.83	3.29	2.47	1.01
	Output Torque	8720	9650	11000	12800	14200	15100	16100	17100	19200
60	Input HP	5.03	4.64	4.30	3.82	3.36	3.07	2.63	1.98	.806
	Output Torque	8210	9080	10500	12000	13200	14000	14800	16000	17600
70	Input HP	4.27	3.94	3.66	3.29	2.95	2.71	2.35	1.80	.749
	Output Torque	7720	8520	9780	11400	12600	13400	14300	15500	17200

Ratings based on 1.0 service factor. For AGMA recommended practice on service factors, see page 4.

# Horsepower and Torque Ratings

## Center Distance 7.000"

Ratio	Worm Speed RPM	1750	1450	1150	865	680	575	450	300	100
5-1/8	Input HP	52.5	48.2	43.2	37.4	34.1	31.8	27.9	21.3	8.80
	Output Torque	9210	10200	11500	13200	15200	16400	18600	21100	25300
7-2/5	Input HP	43.1	39.3	35.4	30.7	28.1	25.7	22.5	16.8	6.74
	Output Torque	10900	11900	13400	15400	17900	19200	21400	23700	27600
8-3/5	Input HP	37.2	35.5	32.0	26.9	24.2	23.2	20.2	14.9	5.95
	Output Torque	10700	11900	13600	15800	18200	19700	21600	24200	28000
9-3/4	Input HP	35.7	32.8	29.3	26.0	23.4	21.2	18.7	13.6	5.37
	Output Torque	11600	13000	14600	17100	19400	20800	23400	24900	28500
14-2/3	Input HP	26.5	24.2	21.7	19.4	17.3	15.8	13.6	10.1	4.05
	Output Torque	12800	14000	15900	18600	21100	22500	24600	26900	30800
20-1/2	Input HP	20.7	19.1	17.2	15.4	13.8	12.6	10.9	8.08	3.26
	Output Torque	13600	15200	17100	20000	22600	24400	26400	28600	32800
24-1/2	Input HP	17.8	16.3	14.7	13.1	11.7	10.7	9.22	6.82	2.73
	Output Torque	13800	15200	17200	20100	22600	24100	26700	28200	31900
29-1/2	Input HP	14.8	13.6	12.4	11.0	9.84	8.87	7.62	5.62	2.24
	Output Torque	13600	15000	17100	20000	22300	23600	25400	27300	30600
35-1/2	Input HP	11.5	10.7	9.78	8.78	7.79	7.07	6.02	4.53	1.88
	Output Torque	12800	14200	16000	18800	20800	22000	23600	25700	28700
40	Input HP	11.5	10.5	9.61	8.64	7.73	7.03	6.13	4.56	1.86
	Output Torque	13600	15000	17000	20000	22300	23700	25800	27700	31200
50	Input HP	9.30	8.54	7.79	6.98	6.30	5.75	5.00	3.75	1.56
	Output Torque	13200	14600	16500	19300	21600	23000	24900	26800	30000
60	Input HP	7.47	6.84	6.34	5.64	5.07	4.58	4.00	2.99	1.24
	Output Torque	12400	13600	15500	18100	20200	21300	22900	25000	27400
70	Input HP	6.34	5.83	5.33	4.84	4.38	4.02	3.53	2.68	1.15
	Output Torque	11700	12900	14600	17100	19200	20300	22100	23800	26900
80	Input HP	4.71	4.48	4.15	3.75	3.41	3.10	2.77	2.12	.912
	Output Torque	9870	10900	12300	14600	16300	17400	18700	20500	23200

Ratings based on 1.0 service factor. For AGMA recommended practice on service factors, see page 4.



# Horsepower and Torque Ratings

## Center Distance 8.000"

Ratio	Worm Speed RPM	1750	1450	1150	865	680	575	450	300	100
5-1/8	Input HP	71.3	65.7	59.2	51.3	46.1	42.9	38.4	29.9	12.5
	Output Torque	12500	13900	15800	18100	20700	22700	25700	29800	36200
7-2/5	Input HP	58.8	54.2	48.5	42.1	38.3	35.3	31.2	23.8	9.70
	Output Torque	14800	16400	18500	21300	24500	26700	29900	33800	39800
9-3/4	Input HP	48.7	44.7	40.1	35.1	31.9	29.1	25.6	19.2	7.71
	Output Torque	16100	17800	20100	23200	26700	28700	32000	35500	41100
11-2/3	Input HP	40.2	37.0	33.8	29.6	27.2	25.2	21.9	16.8	6.90
	Output Torque	15900	17700	20200	23300	27000	29400	32400	36600	42900
14 -2/3	Input HP	36.8	33.5	29.9	26.6	23.9	22.0	19.2	14.3	5.76
	Output Torque	17800	19700	22100	25800	29500	31700	35000	38500	44200
16-2/3	Input HP	30.9	28.6	26.1	23.0	21.1	19.5	17.0	13.0	5.4
	Output Torque	17100	19000	21700	25200	29000	31500	34800	39100	45600
17-0/3	Input HP	30.1	27.8	25.3	22.5	20.4	19.3	16.4	12.5	5.22
	Output Torque	16900	18800	21500	25000	28700	31000	34000	37900	43800
20-1/2	Input HP	28.1	25.7	23.1	20.4	18.6	17.0	14.9	11.2	4.59
	Output Torque	18600	20500	23100	26800	30900	32900	36400	40300	46400
24-1/2	Input HP	24.1	22.1	19.9	17.7	16.0	14.5	12.7	9.58	3.88
	Output Torque	18800	20700	23300	27300	31100	33300	36700	40200	46000
25-1/2	Input HP	21.4	20.1	18.3	16.3	15.1	13.7	12.1	9.31	3.85
	Output Torque	17500	19500	22200	25900	29800	32200	35400	39600	46100
29-1/2	Input HP	20.2	18.5	16.6	14.9	13.4	12.2	10.6	7.98	3.22
	Output Torque	18700	20600	23200	27300	30800	32900	36000	39200	44200
40	Input HP	16.2	14.2	13.3	11.5	10.5	9.59	8.41	6.38	2.65
	Output Torque	19600	20500	24200	27100	30800	32800	36100	39400	44800
50	Input HP	12.5	11.4	10.3	9.34	8.50	7.82	6.84	5.22	2.20
	Output Torque	18000	19900	22300	26100	29600	31500	34800	38000	43100
59	Input HP	10.4	9.53	8.64	7.81	7.10	6.62	5.81	4.60	2.09
	Output Torque	17100	19800	21000	24600	27400	29500	32300	36100	41700
60	Input HP	10.2	9.37	8.50	7.68	6.97	6.38	5.59	4.25	1.77
	Output Torque	17200	18900	21400	25100	28300	30100	32800	35500	40000
70	Input HP	8.95	7.82	7.08	6.40	5.88	5.39	4.81	3.73	1.62
	Output Torque	16500	17500	19600	23000	26100	28100	30800	33700	38400

Ratings based on 1.0 service factor. For AGMA recommended practice on service factors, see page 4.

# Horsepower and Torque Ratings

## Center Distance 9.000"

Ratio	Worm Speed RPM	1750	1450	1150	865	680	575	450	300	100
5-1/8	Input HP	92.5	85.4	77.5	67.0	59.7	55.5	50.4	39.8	17.4
	Output Torque	16200	18200	20700	23800	26700	29300	33900	39700	50200
5-5/6	Input HP	78.6	72.7	65.1	58.9	52.1	49.5	44.7	35.5	15.4
	Output Torque	15700	17500	20000	23500	26300	29500	33800	39800	49500
7-2/6	Input HP	76.2	70.5	63.2	54.9	49.7	46.1	41.0	31.7	13.2
	Output Torque	19100	21300	24000	27700	31600	34600	39100	44800	54100
9-3/4	Input HP	65.1	60.2	53.5	46.4	42.4	39.1	34.6	26.4	10.7
	Output Torque	21600	24000	26800	30800	35700	38700	43400	48900	57300
14 -2/3	Input HP	46.9	43.1	38.3	34.0	30.6	27.9	24.1	18.0	7.03
	Output Torque	23100	25600	28500	33400	38000	40900	44800	49400	55500
20-1/2	Input HP	37.8	34.2	30.8	26.8	24.6	22.6	20.1	15.3	6.44
	Output Torque	25100	27400	31100	35500	41000	44300	49600	55700	65500
24-1/2	Input HP	31.6	28.9	26.1	22.8	20.9	19.3	17.0	13.1	5.38
	Output Torque	24800	27300	30800	35600	41100	44400	49200	55100	63700
29-1/2	Input HP	26.5	24.4	21.9	19.4	17.6	16.2	14.2	10.8	4.42
	Output Torque	24800	27300	30700	35700	40900	43800	48600	53500	61400
36	Input HP	20.7	19.3	17.7	16.0	14.5	13.7	12.3	9.68	4.35
	Output Torque	22900	25600	29200	34300	39100	43000	48000	54800	65500
40	Input HP	19.8	18.1	16.3	14.6	13.3	12.1	10.7	8.06	3.31
	Output Torque	24300	26600	29900	35200	40000	42900	47100	51500	58400
50	Input HP	16.3	15.0	13.6	12.0	11.1	10.2	9.12	7.03	3.03
	Output Torque	23800	26200	29700	34300	39300	42400	46900	51100	60800
60	Input HP	13.1	12.3	10.9	9.82	8.89	8.32	7.32	5.64	2.42
	Output Torque	22400	25000	27700	32400	36400	39700	43600	47900	54800
70	Input HP	11.0	10.0	9.23	8.22	7.65	7.12	6.37	5.02	2.22
	Output Torque	20900	23000	26000	30000	34600	37300	41300	46100	53500
80	Input HP	8.22	7.81	7.31	6.75	5.92	5.91	4.93	4.03	1.98
	Output Torque	17100	19000	21700	25300	29000	31300	34300	38300	44300

Ratings based on 1.0 service factor. For AGMA recommended practice on service factors, see page 4.

# Horsepower and Torque Ratings

## Center Distance 10.000"

Ratio	Worm Speed RPM	1750	1450	1150	865	680	575	450	300	100
5-1/8	Input HP	119	107	101	87.4	77.8	71.4	65.0	52.5	23.3
	Output Torque	21000	23700	27200	31000	35300	38300	43800	52500	67500
7-2/6	Input HP	98.9	91.3	82.3	71.5	64.0	58.8	52.9	41.6	17.6
	Output Torque	24900	27700	31400	36000	40800	44300	50600	59100	72300
8-3/5	Input HP	90.8	83.0	74.1	64.9	58.1	52.5	45.4	35.9	15.3
	Output Torque	26700	28500	33000	38400	44300	46400	50400	59000	72700
9-3/4	Input HP	82.5	76.3	68.8	60.0	54.3	50.0	44.6	34.5	14.3
	Output Torque	27300	30500	34600	40000	45700	49600	56100	64400	77000
12-1/4	Input HP	72.2	66.5	60.0	53.5	47.0	43.2	38.0	30.0	11.9
	Output Torque	28900	31900	36200	42800	47300	50800	57200	67100	78700
14 -2/3	Input HP	62.6	57.9	51.8	44.9	41.0	37.8	33.5	25.9	10.7
	Output Torque	30700	34300	38500	44100	50800	55000	61800	70500	83200
15-2/3	Input HP	52.7	48.9	44.5	39.9	35.9	33.8	30.1	23.5	10.4
	Output Torque	27600	30700	35100	41300	46900	51700	58200	66900	80700
20-1 /2	Input HP	48.2	44.6	40.0	34.8	31.7	29.3	26.2	20.4	8.60
	Output Torque	32400	35900	40500	46300	53400	57700	65100	74400	88400
24-1/2	Input HP	40.9	37.7	33.3	29.7	27.1	24.9	22.2	17.2	7.21
	Output Torque	32300	35800	39600	46300	53400	57500	64600	73200	85900
29-1 /2	Input HP	35.1	32.1	29.0	25.5	23.5	21.3	18.9	14.4	5.90
	Output Torque	33100	36400	41000	47500	55000	58500	65100	72500	83000
32-1/2	Input HP	32.0	30.0	27.3	25.0	22.5	20.3	17.5	13.5	5.00
	Output Torque	32200	35800	41000	49900	56400	59000	64900	72300	75600
35-1 /2	Input HP	30.0	28.1	25.5	22.7	20.5	19.0	16.8	12.5	4.60
	Output Torque	32400	36400	41500	48800	55100	59500	66400	71600	75700
40	Input HP	26.3	24.3	21.9	19.3	17.8	16.4	14.6	11.4	4.89
	Output Torque	32100	35600	40100	46200	53200	57300	64100	72200	84400
47	Input HP	22.0	20.0	19.0	16.5	14.3	13.5	12.2	10.1	4.15
	Output Torque	30000	32400	39200	44100	47600	52500	59300	70100	80000
50	Input HP	21.0	19.4	17.6	15.5	14.3	13.1	11.8	9.33	4.04
	Output Torque	31000	34200	38600	44400	51200	55000	61800	69700	80900
60	Input HP	16.9	14.9	14.2	13.0	11.6	10.7	9.57	7.42	3.24
	Output Torque	29300	30900	36400	43300	48600	51800	57700	64200	74100
70	Input HP	14.3	13.0	11.9	10.5	9.81	9.10	8.26	6.60	2.95
	Output Torque	27400	30100	34000	39000	44900	48400	57200	61500	71800
80	Input HP	10.1	9.70	9.00	8.12	7.60	7.10	6.25	5.15	2.45
	Output Torque	21600	24100	27500	31800	36900	40200	44500	50200	59000

Ratings based on 1.0 service factor. For AGMA recommended practice on service factors, see page 4.

# Horsepower and Torque Ratings

## Center Distance 12.000"

Ratio	Worm Speed RPM	1750	1450	1150	865	680	575	450	300	100
5-1/9	Input HP	176	164	149	132	118	107	93.7	77.6	35.6
	Output Torque	31200	35000	39900	47000	53100	56000	63200	77700	103000
6-5/6	Input HP	158	145	130	113	101	92.1	82.1	67.1	29.1
	Output Torque	37000	40700	46100	52600	59700	64000	72800	88700	111000
7-2/6	Input HP	152	141	128	112	99.7	88.7	80.5	65.0	28.6
	Output Torque	38200	43000	49100	57000	64000	67100	77400	92800	118000
9-3/4	Input HP	129	119	108	94.6	84.0	75.3	68.3	54.6	23.4
	Output Torque	43100	48100	54900	63300	71100	75100	86500	102000	127000
11-1/4	Input HP	120	110	100	88.1	77.9	72.1	62.0	48.1	22.1
	Output Torque	45700	50300	57600	66800	75300	81100	89000	101000	133000
12-1/4	Input HP	112	104	93.0	82.0	73.7	67.0	59.0	46.0	22.0
	Output Torque	45700	51300	57700	66900	75900	83700	91900	105000	146000
13-1/3	Input HP	102	94.2	83.9	73.9	66.0	61.1	55.0	41.8	18.2
	Output Torque	45500	50500	56400	65500	73800	80500	92100	102000	129000
14 -2/3	Input HP	94.1	88.7	80.2	69.6	62.4	56.0	50.8	40.1	17.2
	Output Torque	46500	52700	59900	68700	77700	82200	94400	110000	135000
20-1/2	Input HP	74.0	68.4	61.7	54.0	48.4	43.6	39.3	31.1	13.4
	Output Torque	50100	55600	63100	72400	82100	87000	99200	115000	139000
24-1/2	Input HP	63.4	58.6	53.1	46.2	41.7	37.7	34.1	27.0	11.7
	Output Torque	50500	56300	63800	73000	83000	88000	100000	117000	142000
29-1/2	Input HP	53.3	49.3	44.4	38.7	35.1	31.7	28.6	22.4	9.63
	Output Torque	50500	56200	63300	72600	83000	87800	99500	114000	136000
40	Input HP	40.3	38.1	33.7	29.5	26.9	24.3	22.1	17.7	7.82
	Output Torque	49800	56400	62600	71700	81600	86300	98400	114000	138000
50	Input HP	32.4	30.0	27.3	24.0	21.8	19.9	18.0	14.3	6.52
	Output Torque	48600	53900	61100	70100	79600	84700	95900	111000	133000
60	Input HP	26.2	24.2	21.9	19.3	17.8	16.0	14.6	11.6	5.20
	Output Torque	42800	50800	57100	65800	75400	79600	89900	103000	122000
70	Input HP	21.3	19.8	17.9	15.8	14.6	13.4	12.3	9.94	4.63
	Output Torque	41800	46600	52500	60100	68400	72600	83000	95900	116000
80	Input HP	15.7	14.7	13.5	12.1	11.1	10.1	9.35	7.61	3.25
	Output Torque	32200	35800	40900	48100	54800	60200	67500	77300	92600

Ratings based on 1.0 service factor. For AGMA recommended practice on service factors, see page 4.

# Horsepower and Torque Ratings

## Center Distance 14.000"

Ratio	Worm Speed RPM	1750	1450	1150	865	680	575	450	300	100
5-1/10	Input HP	265	242	213	185	160	145	127	103	51.2
	Output Torque	46700	51500	57100	65800	72200	77000	85600	103000	149000
6-5/8	Input HP	230	210	182	158	137	120	107	85.0	42.0
	Output Torque	51900	57100	61900	70700	78000	80000	92200	108000	157000
7-3/7	Input HP	215	192	167	142	123	112	101	84.7	39.7
	Output Torque	55000	59500	64900	73100	80500	86300	99400	123000	168000
9-4/5	Input HP	175	158	140	120	103	93.8	85.4	70.5	35.0
	Output Torque	58900	64000	71400	81100	88200	94500	109000	134000	192000
14-3/4	Input HP	122	109	96.2	84.5	75.7	70.2	64.4	52.5	23.7
	Output Torque	60600	65500	72700	84300	95400	104000	121000	146000	188000
16-1/3	Input HP	106	98.4	89.5	79.9	73.0	66.5	61.7	50.0	23.0
	Output Torque	58200	64800	74000	84100	99900	107000	125000	151000	194000
16-2/3	Input HP	106	98.0	85.0	75.1	65.3	61.2	55.0	45.2	21.0
	Output Torque	59200	66700	70900	83000	91200	100000	114000	138000	183000
19-2/3	Input HP	95.1	83.6	76.0	67.1	59.7	55.9	51.1	41.0	18.9
	Output Torque	62400	66100	75400	87700	98600	108000	126000	148000	193000
24-1/2	Input HP	82.2	72.0	63.7	55.9	50.0	47.0	43.1	35.4	16.1
	Output Torque	66100	69800	77500	89600	101000	111000	129000	155000	198000
29-1/2	Input HP	68.8	62.5	53.5	47.1	42.2	39.8	36.3	29.9	13.6
	Output Torque	65500	71500	77000	89200	100000	111000	128000	153000	191000
39-1/2	Input HP	49.9	46.3	42.0	37.1	33.6	31.7	28.8	23.5	10.7
	Output Torque	62100	69400	78500	90900	103000	114000	130000	155000	193000
50	Input HP	43.0	38.4	32.5	28.8	25.9	24.6	22.5	18.7	8.86
	Output Torque	65100	69800	74000	86500	96400	106000	122000	147000	186000
60	Input HP	35.2	31.2	26.5	24.2	21.3	20.2	18.6	15.6	7.36
	Output Torque	62100	66200	70100	84400	91600	101000	116000	141000	176000
70	Input HP	28.1	25.5	22.1	19.8	18.1	17.0	15.8	13.4	6.69
	Output Torque	55500	60400	65600	76000	83300	94400	109000	132000	170000
79	Input HP	21.5	20.5	19.0	17.1	15.1	14.2	13.1	11.3	5.22
	Output Torque	46200	51400	58700	69100	76900	86400	99200	11700	146000

Ratings based on 1.0 service factor. For AGMA recommended practice on service factors, see page 4.

# Horsepower and Torque Ratings

## Center Distance 17.000"

Ratio	Worm Speed RPM	1750	1450	1150	865	680	575	450	300	100
5-1/10	Input HP	430	390	345	300	265	245	208	155	82.7
	Output Torque	76000	83000	89200	107000	125000	131000	141000	156000	242000
6-3/8	Input HP	362	327	283	240	210	190	172	145	74.2
	Output Torque	80200	87300	95200	107000	118000	126000	145000	182000	269000
7-3/7	Input HP	355	315	275	232	202	182	155	126	62.9
	Output Torque	91300	97800	107000	119000	132000	140000	152000	184000	266000
8-2/7	Input HP	351	297	261	218	188	168	149	126	63.2
	Output Torque	100000	102000	113000	124000	137000	143000	163000	204000	293000
9-1/7	Input HP	312	284	245	210	183	166	142	115	55.4
	Output Torque	98600	108000	117000	133000	145000	156000	170000	204000	285000
9-4/5	Input HP	306	277	240	204	177	160	139	110	53.7
	Output Torque	104000	113000	123000	138000	153000	162000	178000	208000	296000
12-3/4	Input HP	240	220	198	152	142	128	112	93.0	44.6
	Output Torque	104000	114000	131000	133000	155000	165000	184000	226000	308000
14 -3/4	Input HP	215	192	165	138	120	108	97.2	82.0	39.1
	Output Torque	107000	115000	124000	138000	153000	160000	184000	230000	313000
16-1/3	Input HP	163	151	136	121	111	104	92.0	79.7	38.7
	Output Torque	89500	99700	113000	133000	153000	169000	190000	241000	330000
19-2/3	Input HP	156	142	125	103	92.3	85.1	77.2	65.0	31.2
	Output Torque	103000	113000	125000	149000	154000	167000	191000	238000	322000
21-1/3	Input HP	142	133	118	98.3	85.1	77.3	66.4	63.1	29.9
	Output Torque	100000	123000	126000	138000	151000	161000	175000	241000	321000
24-1/2	Input HP	137	127	112	94.1	81.2	73.0	64.8	54.5	26.5
	Output Torque	111000	124000	137000	151000	165000	174000	196000	242000	329000
29-1/2	Input HP	120	112	100	83.5	70.0	64.9	55.2	46.3	22.5
	Output Torque	115000	130000	145000	155000	169000	184000	197000	242000	326000
39-1/2	Input HP	89.4	81.0	71.0	62.5	55.0	50.0	45.0	35.3	17.0
	Output Torque	112000	124000	134000	155000	172000	184000	207000	236000	311000
50	Input HP	79.1	72.2	64.2	54.5	49.5	45.1	37.1	29.0	14.5
	Output Torque	121000	133000	149000	160000	187000	199000	206000	232000	310000
60	Input HP	63.3	58.3	51.5	46.1	38.6	35.2	31.1	23.8	12.1
	Output Torque	113000	125000	139000	161000	120000	179000	199000	220000	293000
70	Input HP	47.5	42.5	37.0	34.6	31.4	27.3	24.4	20.5	11.1
	Output Torque	95000	102000	111000	135000	148000	155000	165000	206000	284000

Ratings based on 1.0 service factor. For AGMA recommended practice on service factors, see page 4.



# Horsepower and Torque Ratings

## Center Distance 18.000"

Ratio	Worm Speed RPM	1750	1450	1150	865	680	575	450	300	100
6-4/7	Input HP	440	395	350	303	265	238	202	154	86
	Output Torque	100000	109000	121000	140000	156000	164000	177000	202000	325000
7-3/5	Input HP	407	370	325	280	240	215	185	137	80
	Output Torque	108000	118500	132000	150000	161500	172000	187000	206000	345000
8-3/5	Input HP	377	342	305	260	223	200	172	130	71
	Output Torque	112000	123000	137000	156000	169000	179000	195000	219000	348000
9-4/5	Input HP	349	315	280	244	213	191	166	122	68
	Output Torque	116000	125000	141000	163000	179000	190000	209000	229000	364000
12-1/4	Input HP	300	270	235	200	174	156	135	103	56
	Output Torque	133000	137000	151000	171000	187000	197000	216000	244000	386000
14 -3/4	Input HP	240	215	190	163	143	130	112	84	46
	Output Torque	122000	131000	146000	165000	183000	195000	212000	241000	371000
17-1/3	Input HP	212	188	165	142	125	113	97	76	40
	Output Torque	125000	133000	146000	165000	184000	196000	213000	243000	374000
24-1/2	Input HP	170	155	135	112	97	87	75	60	35
	Output Torque	139500	154000	166500	182000	198000	208000	234000	266000	434000
26-1/2	Input HP	158	141	124	103	89	80	69	54	32
	Output Torque	140000	149000	165000	181000	196000	206000	226000	256000	417000
32-1/2	Input HP	134	118	102	86	75	69	60	47	27
	Output Torque	143000	152000	167000	182000	198000	213000	231000	266000	430000
35-1/2	Input HP	120	106	93	79	68	61	53	41	24
	Output Torque	139000	146000	161000	180000	194000	203000	220000	248000	402000
44	Input HP	104	92	80	70	61	56	49	39	23
	Output Torque	145000	154000	168000	192000	208000	226000	246000	276000	434000
53	Input HP	74	67	60	51	45	42	37	30	17
	Output Torque	122000	131000	145000	163000	180000	191000	210000	238000	367000
62	Input HP	62	56	51	45	40	37	32	25	16
	Output Torque	116000	123000	138000	162000	178000	190000	208000	221000	351000
70	Input HP	54	48	42	38	33	30	26	21	14
	Output Torque	110000	118000	130000	153000	162000	168000	186000	205000	332000

Ratings based on 1.0 service factor. For AGMA recommended practice on service factors, see page 4.

# Horsepower and Torque Ratings

## Center Distance 20.000"

Ratio	Worm Speed RPM	1750	1450	1150	865	680	575	450	300	100
5-1/10	Input HP	625	580	520	445	400	370	315	240	122
	Output Torque	111000	124000	141000	159000	181000	197000	215000	243000	360000
7-3/7	Input HP	530	480	425	360	304	270	227	176	91.9
	Output Torque	136000	149000	165000	187000	200000	210000	224000	258000	392000
9-4/5	Input HP	464	426	380	317	270	240	196	153	77.2
	Output Torque	156000	174000	195000	216000	232000	239000	250000	294000	428000
11-2/5	Input HP	390	355	315	265	225	200	170	130	62
	Output Torque	153000	166000	186000	206000	223000	232000	246000	276000	393000
14-3/4	Input HP	325	295	265	225	192	174	150	118	58.0
	Output Torque	164000	178000	202000	227000	246000	263000	287000	324000	472000
19-2/3	Input HP	252	225	200	163	144	130	113	92.5	45.8
	Output Torque	166000	179000	201000	217000	242000	256000	284000	342000	480000
24-1/2	Input HP	215	192	165	134	114	106	89.5	77.6	37.9
	Output Torque	175000	188000	203000	219000	234000	257000	274000	345000	480000
29-1/2	Input HP	195	175	150	116	96.0	85.1	76.8	65.6	32.9
	Output Torque	189000	204000	219000	224000	234000	243000	277000	347000	484000
32-1/2	Input HP	170	155	130	108	92.1	80.0	70.2	55.2	31.7
	Output Torque	176000	192000	204000	223000	239000	247000	273000	311000	497000
36-1/2	Input HP	150	137	112	100	85.2	75.0	65.0	51.0	27.7
	Output Torque	173000	190000	195000	230000	245000	254000	277000	310000	484000
39-1/2	Input HP	135	125	110	90.0	76.2	70.0	59.0	50.6	25.7
	Output Torque	170000	190000	210000	227000	240000	258000	274000	343000	477000
50	Input HP	110	104	95.0	78.5	66.3	60.0	49.0	41.1	20.5
	Output Torque	172000	192000	222000	242000	256000	271000	278000	330000	454000
60	Input HP	88.6	79.9	70.2	58.3	49.9	46.0	41.2	33.4	17.4
	Output Torque	161000	175000	192000	210000	222000	240000	269000	315000	435000
70	Input HP	69.6	63.0	56.0	48.3	41.6	38.1	33.8	28.3	15.8
	Output Torque	142000	155000	171000	193000	208000	222000	245000	296000	421000

Ratings based on 1.0 service factor. For AGMA recommended practice on service factors, see page 4.

# Horsepower and Torque Ratings

## Center Distance 21.837"

Ratio	Worm Speed RPM	1450	1150	865	680	575	450	300	100
6-1/9	Input HP	640	565	485	430	390	345	273	153
	Output Torque	165000	184000	210000	236000	252000	282000	333000	530000
6-5/8	Input HP	630	555	478	422	384	334	264	145
	Output Torque	175000	194000	199000	249000	268000	297000	348000	556000
7-2/7	Input HP	585	515	430	385	350	305	240	135
	Output Torque	176000	197500	221000	250000	269000	298000	349000	560000
7-6/7	Input HP	565	495	420	365	335	290	230	133
	Output Torque	186000	204000	229000	253000	273000	299000	354000	603000
8-5/6	Input HP	540	470	400	349	320	278	223	125
	Output Torque	200000	218000	247000	274000	296000	326000	389000	631000
10-1/4	Input HP	508	438	370	321	290	258	204	113
	Output Torque	219000	236000	262000	290000	310000	349000	410000	660000
11-1/4	Input HP	465	415	350	304	276	240	190	106
	Output Torque	220000	246000	274000	302000	321000	357000	418000	669000
11-3/4	Input HP	450	400	338	292	265	230	182	104
	Output Torque	223000	247000	276000	303000	322000	358000	419000	693000
13-1/4	Input HP	364	318	271	238	218	190	154	86.0
	Output Torque	201000	220000	248000	275000	279000	330000	395000	636000
13-2/3	Input HP	352	308	263	231	211	185	148	84.0
	Output Torque	201000	220000	248000	275000	297000	329000	390000	635000
17-2/3	Input HP	293	248	215	189	173	151	120	69.0
	Output Torque	212000	226000	258000	288000	309000	342000	400000	655000
19-2/3	Input HP	265	225	195	170	155	135	109	62.0
	Output Torque	213000	227000	260000	286000	306000	340000	406000	653000
22-1/3	Input HP	233	203	173	154	140	124	99.0	56.0
	Output Torque	213000	231000	259000	290000	310000	346000	409000	660000
23-1/3	Input HP	220	190	164	146	133	116	93.0	54.0
	Output Torque	208000	224000	255000	286000	307000	336000	399000	649000
26-1/2	Input HP	214	188	160	142	130	114	92.0	53.0
	Output Torque	228000	252000	284000	317000	341000	376000	446000	701000
35-1/2	Input HP	156	138	115	104	95.0	84.0	67.0	38.0
	Output Torque	216000	240000	263000	297000	319000	354000	413000	663000
45	Input HP	141	125	105	96.0	89.0	78.0	63.0	35.0
	Output Torque	246000	271000	296000	338000	365000	401000	470000	720000
50	Input HP	125	112	97.2	87.0	80.1	72.0	57.0	32.0
	Output Torque	228000	254000	296000	330000	356000	401000	456000	662000
63	Input HP	98.0	87.0	76.0	68.0	63.0	56.0	46.0	28.0
	Output Torque	225000	248000	281000	312000	336000	374000	441000	700000
71	Input HP	80.0	70.0	60.0	55.0	50.0	45.0	35.0	24.0
	Output Torque	202000	222000	249000	282000	303000	333000	376000	620000

Ratings based on 1.0 service factor. For AGMA recommended practice on service factors, see page 4.

# Horsepower and Torque Ratings

## Center Distance 24.000"

Ratio	Worm Speed RPM	1150	865	680	575	450	300	100
4-1/12	Input HP	920	805	720	650	570	430	230
	Output Torque	200000	231000	261000	278000	307000	352000	544000
5-1/10	Input HP	800	690	610	545	470	360	190
	Output Torque	218000	248000	278000	294000	322000	366000	565000
6-8/9	Input HP	670	565	490	445	390	315	164
	Output Torque	241000	264000	293000	315000	349000	418000	654000
7-3/8	Input HP	645	535	460	416	360	285	150
	Output Torque	253000	279000	305000	325000	357000	419000	643000
7-6/7	Input HP	605	500	430	390	340	265	145
	Output Torque	253000	276000	301000	315000	357000	413000	662000
8-1/7	Input HP	575	480	415	375	325	255	140
	Output Torque	246000	272000	297000	314000	350000	403000	637000
9-5/6	Input HP	550	465	402	360	312	244	137
	Output Torque	286000	320000	352000	372000	409000	474000	769000
10-1/5	Input HP	495	405	350	312	270	205	115
	Output Torque	266000	287000	314000	329000	364000	410000	672000
14-3/4	Input HP	390	325	281	255	220	170	100
	Output Torque	300000	332000	363000	388000	425000	484000	821000
17-2/3	Input HP	348	288	248	224	193	146	88.0
	Output Torque	318000	348000	380000	404000	439000	490000	831000
19-2/3	Input HP	295	246	216	195	167	129	80.0
	Output Torque	299000	330000	363000	387000	420000	479000	820000
22-1/3	Input HP	280	232	195	175	152	120	73.0
	Output Torque	315000	347000	369000	397000	423000	493000	850000
24-2/3	Input HP	262	216	185	167	145	113	67.0
	Output Torque	328000	357000	387000	410000	449000	513000	846000
26-1/2	Input HP	245	200	170	152	130	105	62.0
	Output Torque	324000	350000	385000	400000	430000	508000	847000
29-1 /2	Input HP	230	185	160	144	124	97.0	57.0
	Output Torque	342000	360000	390000	415000	450000	516000	854000
39-1 /2	Input HP	168	140	121	110	95.0	72.0	45.0
	Output Torque	324000	355000	384000	410000	449000	492000	845000
41	Input HP	155	130	115	104	88.0	70.0	43.0
	Output Torque	308000	342000	380000	402000	425000	493000	830000
44-1/2	Input HP	150	125	105	97.0	84.0	67.0	42.0
	Output Torque	324000	357000	375000	406000	442000	507000	860000
50	Input HP	144	116	100	91.0	80.0	65.0	40.0
	Output Torque	344000	361000	390000	415000	458000	539000	905000
60	Input HP	111	95.0	84.0	76.0	66.0	51.0	32.0
	Output Torque	310000	346000	380000	404000	439000	488000	821000
70	Input HP	85.0	73.0	65.0	60.0	55.0	44.0	27.0
	Output Torque	270000	300000	331000	356000	407000	469000	756000
89	Input HP	55.0	50.0	45.0	43.0	40.0	35.0	22.0
	Output Torque	215000	256000	285000	318000	368000	465000	760000

Ratings based on 1.0 service factor. For AGMA recommended practice on service factors, see page 6.

# Horsepower and Torque Ratings

## Center Distance 26.500"

Ratio	Worm Speed RPM	865	680	575	450	300	100
4-1/12	Input HP	884	805	761	616	521	325
	Output Torque	254000	293000	323000	338000	427000	777000
5-7/10	Input HP	754	625	583	478	404	239
	Output Torque	301000	316000	348000	364000	459000	791000
6-3/8	Input HP	710	590	549	451	383	225
	Output Torque	316000	333000	367000	384000	484000	827000
7-3/8	Input HP	655	543	507	416	353	205
	Output Torque	337000	355000	390000	409000	515000	868000
7-7/9	Input HP	600	500	465	383	324	183
	Output Torque	326000	343000	378000	395000	499000	819000
9-1/5	Input HP	562	466	432	358	304	172
	Output Torque	360000	378000	416000	435000	549000	896000
11-2/5	Input HP	498	412	387	317	270	154
	Output Torque	392000	412000	454000	475000	599000	981000
16-1/4	Input HP	372	309	289	238	199	111
	Output Torque	412000	433000	477000	499000	617000	984000
20-1/3	Input HP	310	257	242	201	167	94.3
	Output Torque	423000	445000	491000	513000	633000	1020000
21-1/3	Input HP	301	273	234	192	161	94.5
	Output Torque	430000	451000	497000	520000	636000	1040000
22-1/3	Input HP	284	236	222	182	154	86.7
	Output Torque	423000	446000	491000	513000	636000	1007000
23-2/3	Input HP	273	227	213	183	147	86.2
	Output Torque	431000	453000	490000	505000	641000	1040000
24-1/2	Input HP	264	219	205	169	142	80.9
	Output Torque	428000	449000	495000	518000	641000	1020000
29-1/3	Input HP	222	185	173	142	121	68.1
	Output Torque	426000	448000	494000	516000	643000	999000
30-1/2	Input HP	221	182	171	141	118	71.9
	Output Torque	435000	457000	503000	527000	645000	1065000
34-1/2	Input HP	195	164	155	128	108	65.0
	Output Torque	434000	456000	503000	526000	645000	105700
37-1/2	Input HP	177	147	138	115	97.8	55.1
	Output Torque	424000	446000	492000	514000	641000	986000
50	Input HP	132	115	107	91.9	80.4	49.9
	Output Torque	397000	436000	481000	512000	645000	1055000
51	Input HP	125	111	104	88.2	75.2	46.3
	Output Torque	392000	429000	473000	504000	621000	1005000
60	Input HP	106	92	87.3	75.0	63.4	39.7
	Output Torque	375000	411000	452000	482000	592000	966000
100	Input HP	46.2	41.1	38.8	33.5	29.4	19.0
	Output Torque	243000	266000	293000	312000	389000	606000

Ratings based on 1.0 service factor. For AGMA recommended practice on service factors, see page 4.

# Horsepower and Torque Ratings

## Center Distance 27.000"

Ratio	Worm Speed RPM	865	680	575	450	300	100
4-7/11	Input HP	742	698	651	587	497	306
	Output Torque	238000	291000	320000	368000	464000	835000
5-7/9	Input HP	646	585	544	490	415	249
	Output Torque	260000	302000	333000	383000	480000	834000
6-5/8	Input HP	703	610	558	490	392	219
	Output Torque	330000	362000	389000	437000	515000	845000
7-5/8	Input HP	640	545	495	430	360	192
	Output Torque	340000	372000	399000	440000	550000	850000
8-5/6	Input HP	565	482	438	380	325	167
	Output Torque	350000	378000	406000	448000	565000	855000
9-2/5	Input HP	540	460	415	360	310	160
	Output Torque	355000	384000	410000	454000	570000	865000
11-4/5	Input HP	480	407	360	305	240	135
	Output Torque	392000	418400	433000	468700	547300	893500
15-1/4	Input HP	400	330	300	265	210	110
	Output Torque	420000	442000	475000	530000	624000	940000
16-3/4	Input HP	375	312	280	255	203	104
	Output Torque	436000	457000	483000	554000	650000	970000
17-1/3	Input HP	365	305	272	250	198	101
	Output Torque	437000	462000	486000	560000	658000	975000
19-1/3	Input HP	334	280	250	228	180	94.0
	Output Torque	440000	467000	492000	570000	662000	988000
19-2/3 LH	Input HP	330	276	247	225	179	93.0
	Output Torque	438000	465000	490000	568000	665000	963000
21-2/3	Input HP	305	257	233	208	165	87.0
	Output Torque	442000	473000	500000	574000	672000	995000
22-2/3	Input HP	292	250	227	203	161	83.0
	Output Torque	448000	487000	522000	587000	687000	1000000
24-1/3	Input HP	279	240	219	195	157	78.0
	Output Torque	450000	500000	525000	610000	690000	1020000
29-1/2	Input HP	230	214	194	173	131	68.5
	Output Torque	455000	537000	573000	640000	718000	1040000
30-1/2	Input HP	225	210	190	170	128	68.0
	Output Torque	460000	540000	577000	653000	723000	1030000
35-1/2	Input HP	194	180	165	145	111	56.0
	Output Torque	455000	532000	570000	640000	713000	1010000
37-1/2	Input HP	183	170	156	137	105	55.0
	Output Torque	450000	526000	567000	632000	705000	1010000
45	Input HP	153	135	125	115	88.0	46.0
	Output Torque	445000	492000	532000	615000	688000	990000
51	Input HP	137	120	107	100	78.0	43.0
	Output Torque	438000	483000	510000	586000	660000	980000
53	Input HP	130	112	100	93.0	72.0	38.0
	Output Torque	435000	480000	500000	582000	659000	970000
62	Input HP	110	98.0	89.0	79.0	64.0	34.0
	Output Torque	430000	470000	490000	565000	647000	915000

Ratings based on 1.0 service factor. For AGMA recommended practice on service factors, see page 4.



# Horsepower and Torque Ratings

## Center Distance 28.000"

Ratio	Worm Speed RPM	865	680	575	450	300	100
6-7/8	Input HP	768	670	612	545	448	213
	Output Torque	376000	413000	444000	502000	616000	902000
7-7/8	Input HP	678	600	550	480	395	197
	Output Torque	377000	422000	456000	505000	620000	905000
9-1/6	Input HP	580	530	490	430	350	170
	Output Torque	378000	431000	472000	528000	640000	909000
9-4/5	Input HP	550	500	465	410	330	160
	Output Torque	383000	434000	478000	530000	643000	910000
13-1/4	Input HP	460	400	360	320	255	130
	Output Torque	422000	466000	496000	562000	663000	935000
16-2/3	Input HP	400	340	315	270	215	109
	Output Torque	458000	493000	545000	582000	702000	1025000
17-2/3	Input HP	380	325	300	260	200	105
	Output Torque	460000	500000	550000	606000	710000	1025000
19-2/3	Input HP	350	305	275	245	190	95
	Output Torque	472000	520000	552000	625000	715000	1050000
22-2/3	Input HP	315	285	255	225	175	89
	Output Torque	485000	540000	587000	652000	750000	1080000
23-2/3	Input HP	305	270	250	220	170	86
	Output Torque	487000	552000	600000	663000	752000	1090000
25-1/3	Input HP	290	260	240	210	165	81
	Output Torque	495000	565000	610000	680000	786000	1100000
26-1/2	Input HP	280	250	230	203	160	79
	Output Torque	500000	567000	613000	685000	795000	1135000
31-1/3	Input HP	240	215	197	175	140	72
	Output Torque	502000	570000	625000	690000	807000	1160000
36-1/2	Input HP	205	185	173	155	124	63
	Output Torque	490000	558000	608000	690000	807000	1140000
39-1/2	Input HP	189	168	157	143	113	60
	Output Torque	486000	550000	602000	685000	795000	1140000
40	Input HP	185	160	153	140	110	57
	Output Torque	482000	545000	593000	682000	785000	1120000
47	Input HP	160	140	133	121	95	50
	Output Torque	478000	530000	588000	680000	770000	1100000
56	Input HP	130	118	114	90	80	40
	Output Torque	455000	518000	585000	644000	740000	1080000
65	Input HP	112	100	95	85	70	35
	Output Torque	445000	500000	556000	620000	735000	975000

Ratings based on 1.0 service factor. For AGMA recommended practice on service factors, see page 4.

# Horsepower and Torque Ratings

## Center Distance 30.000"

Ratio	Worm Speed RPM	865	680	575	450	300	100
6-5/9	Input HP	965	810	690	620	490	290
	Output Torque	442400	467500	513000	535000	634000	1114000
7-3/8	Input HP	870	740	663	570	450	260
	Output Torque	454000	485000	516000	566000	666000	1120000
8-5/8	Input HP	790	670	602	520	406	225
	Output Torque	480000	516000	549000	602000	700000	1130000
9-5/6	Input HP	740	625	560	480	378	200
	Output Torque	511000	547000	580000	631000	740000	1140000
14-1 /4	Input HP	535	460	410	360	287	163
	Output Torque	530000	576000	607000	680000	797000	1300000
14-3/4	Input HP	520	445	400	350	280	165
	Output Torque	533000	579000	614000	684000	808000	1360000
17-1/3	Input HP	460	400	352	307	245	140
	Output Torque	543000	600000	623000	690000	814000	1330000
19-2/3	Input HP	420	360	322	280	225	130
	Output Torque	567000	610000	649000	715000	845000	1400000
24-2/3	Input HP	340	288	260	227	182	108
	Output Torque	568000	610000	650000	716000	845000	1420000
29-1/2	Input HP	315	267	240	205	180	100
	Output Torque	625000	669000	706000	762000	984000	1530000
34-1/2	Input HP	280	235	210	180	145	85.0
	Output Torque	646000	680000	712000	773000	905000	1490000
39-1/2	Input HP	208	179	163	143	114	71.0
	Output Torque	540000	583000	623000	688000	810000	1400000
50	Input HP	192	167	150	127	103	65.0
	Output Torque	630000	686000	707000	755000	886000	1540000
51	Input HP	185	158	140	120	98.0	60.0
	Output Torque	603000	650000	674000	725000	860000	1450000
60	Input HP	155	132	120	105	85.0	52.0
	Output Torque	582000	622000	661000	723000	849000	1430000
78	Input HP	120	103	95.0	85.0	70.0	40.0
	Output Torque	520000	550000	596000	667000	792000	1190000

Ratings based on 1.0 service factor. For AGMA recommended practice on service factors, see page 4.

# Horsepower and Torque Ratings

## Center Distance 36.000"

Ratio	Worm Speed RPM	865	680	575	450	300	100
10-1/7	Input HP	1060	883	783	663	515	280
	Output Torque	755000	804000	840000	904000	1040000	1650000
11-2/5	Input HP	980	820	725	610	472	260
	Output Torque	785000	835000	870000	930000	1070000	1850000
13-1/5	Input HP	880	730	650	550	430	245
	Output Torque	812000	852000	895000	965000	1120000	1860000
14-1/4	Input HP	830	695	620	528	410	235
	Output Torque	827000	880000	922000	996000	1140000	1910000
15-1/5	Input HP	816	680	608	510	396	230
	Output Torque	866000	916000	964000	1030000	1180000	1960000
20-1/4	Input HP	660	551	485	415	315	179
	Output Torque	925000	975000	1020000	1100000	1230000	2000000
23-1/3	Input HP	585	490	440	370	288	162
	Output Torque	938000	995000	1050000	1110000	1280000	2050000
25-1/3	Input HP	535	450	400	340	263	150
	Output Torque	927000	984000	1030000	1110000	1260000	2030000
26-2/3	Input HP	500	450	400	340	260	140
	Output Torque	893700	989800	1052000	1117000	1267000	1929000
29-2/3	Input HP	450	380	338	285	220	126
	Output Torque	905000	969000	1000000	1070000	1210000	1980000
39-1/2	Input HP	320	270	241	240	160	96.0
	Output Torque	844000	897000	942000	1000000	1150000	1940000
49-1/2	Input HP	240	202	181	155	123	77.0
	Output Torque	774000	822000	860000	922000	1060000	1830000
73	Input HP	147	132	122	108	80.0	49.7
	Output Torque	660000	764000	808000	906000	971000	1570000
75	Input HP	140	128	111	102	81.0	50.0
	Output Torque	650000	746000	752000	865000	990000	1580000

Ratings based on 1.0 service factor. For AGMA recommended practice on service factors, see page 4.

# Horsepower and Torque Ratings

## Center Distance 42.000"

Ratio	Worm Speed RPM	865	680	575	450	300	100
10-1/8	Input HP	1200	1080	1010	875	680	410
	Output Torque	855000	980000	1080000	1190000	1380000	2400000
14-1/6	Input HP	1050	930	840	710	540	320
	Output Torque	1040000	1160000	1210000	1340000	1520000	2580000
22-3/4	Input HP	750	605	555	465	380	210
	Output Torque	1180000	1200000	1300000	1380000	1680000	2620000
25-1/3	Input HP	680	550	510	425	355	200
	Output Torque	1180000	1210000	1320000	1400000	1740000	2700000
28-1/3	Input HP	625	500	460	395	322	185
	Output Torque	1200000	1230000	1330000	1450000	1740000	2730000
29-2/3	Input HP	610	495	455	390	312	180
	Output Torque	1210000	1240000	1340000	1480000	1740000	2730000
34-1/2	Input HP	515	410	385	340	260	150
	Output Torque	1200000	1230000	1320000	1470000	1650000	2600000
39-1/2	Input HP	450	355	330	290	220	130
	Output Torque	1180000	1190000	1310000	1450000	1620000	2520000
49-1/2	Input HP	300	270	250	210	170	101
	Output Torque	975000	1110000	1200000	1270000	1520000	2600000
59-1/2	Input HP	250	225	210	180	145	95.0
	Output Torque	950000	1080000	1180000	1260000	1500000	2560000

Ratings based on 1.0 service factor. For AGMA recommended practice on service factors, see page 4.

# Horsepower and Torque Ratings

## Center Distance 48.000"

Ratio	Worm Speed RPM	865	680	575	450	300	100
10-1/9	Input HP	1500	1310	1150	1050	850	500
	Output Torque	1070000	1190000	1230000	1430000	1720000	2940000
16-5/6	Input HP	950	850	800	700	575	350
	Output Torque	1120000	1280000	1410000	1570000	1910000	3300000
20-1/5	Input HP	900	775	710	585	500	300
	Output Torque	1260000	1380000	1480000	1550000	1970000	3360000
25-1/4	Input HP	730	600	575	510	410	245
	Output Torque	1280000	1380000	1490000	1680000	2010000	3390000
29-2/3	Input HP	620	540	500	440	350	215
	Output Torque	1260000	1400000	1520000	1700000	2000000	3460000
34-1/3	Input HP	565	470	440	400	310	195
	Output Torque	1310000	1380000	1520000	1750000	2010000	3450000
40-1/2	Input HP	450	400	370	330	275	165
	Output Torque	1220000	1380000	1500000	1710000	2110000	3440000
49-1/2	Input HP	360	320	300	260	210	130
	Output Torque	1190000	1340000	1470000	1620000	1930000	3280000
57-1/2	Input HP	310	270	250	220	185	115
	Output Torque	1160000	1290000	1400000	1560000	1890000	3170000
69-1/2	Input HP	240	215	195	175	145	95.0
	Output Torque	1070000	1200000	1280000	1420000	1740000	2990000

Ratings based on 1.0 service factor. For AGMA recommended practice on service factors, see page 4.

# Worm and Gear Data

## Center Distance 2.000" Worms

## Face Width 5/8" Gears

Actual Ratio	Circ. Pitch	Out. Dia.	Pitch. Dia.	Root. Dia.	Lead Angle	Pitch. Dia.	Throat Dia.	Out. Dia.
5 1/6	.3044	1.188	.994	.820	30°20'	3.006	3.146	3.382
7 1/4	.3457	1.018	.798	.638	28°53'	3.202	3.324	3.382
9 2/3	.3393	1.080	.864	.636	20°34'	3.136	3.324	3.382
12 1/2	.3833	1.189	.945	.669	14°28'	3.055	3.283	3.382
15 1/2	.3205	1.020	.816	.584	14°02'	3.184	3.376	3.382
20 1/2	.2449	.956	.800	.610	11°02'	3.200	3.350	3.382
25	.3833	1.189	.945	.669	7°21'	3.055	3.283	3.382
30	.3273	1.040	.832	.586	7°08'	3.168	3.372	3.382
38	.2619	.998	.832	.634	5°43'	3.168	3.332	3.382
40	.2500	.980	.820	.622	5°34'	3.180	3.338	3.382
46	.2184	.966	.828	.664	4°48'	3.172	3.308	3.382
50	.2000	.892	.764	.596	4°46'	3.236	3.362	3.382
54	.1880	.930	.810	.666	4°13'	3.190	3.309	3.382
60	.1692	.827	.729	.591	4°14'	3.271	3.369	3.382
70	.1475	.787	.705	.581	3°49'	3.295	3.377	3.382

## Center Distance 2.500" Worms

## Face Width 7/8" Gears

Actual Ratio	Circ. Pitch	Out. Dia.	Pitch. Dia.	Root. Dia.	Lead Angle	Pitch. Dia.	Throat Dia.	Out. Dia.
5 1/6 RH&LH	.4148	1.155	.891	.723	41°39'	4.109	4.237	4 3/8
7 1/4 RH&LH	.4487	1.144	.858	.620	33°40'	4.142	4.332	4 3/8
9 2/3	.4487	1.144	.858	.582	26°31'	4.142	4.368	4 3/8
12 2/3	.3333	1.166	.954	.726	18°26'	4.046	4.236	4 3/8
15 1/2	.4191	1.130	.864	.570	17°10'	4.136	4.378	4 3/8
20 1/2	.3205	1.020	.816	.584	14°02'	4.184	4.376	4 3/8
25 RH&LH	.5062	1.248	.972	.650	9°25'	4.028	4.296	4 3/8
30 RH&LH	.4304	1.136	.890	.600	8°46'	4.110	4.352	4 3/8
40 RH&LH	.3273	1.040	.832	.586	7°08'	4.168	4.372	4 3/8
50	.2619	.998	.832	.634	5°43'	4.168	4.332	4 3/8
60	.2184	.966	.828	.664	4°48'	4.172	4.308	4 3/8
70	.1880	.930	.810	.666	4°14'	4.190	4.308	4 3/8

# Worm and Gear Data

## Center Distance 3.000" Worms

## Face Width 1" Gears

Actual Ratio	Circ. Pitch	Out. Dia.	Pitch. Dia.	Root. Dia.	Lead Angle	Pitch. Dia.	Throat Dia.	Out. Dia.
5 1/6 RH&LH	.5026	1.360	1.040	.888	42°43'	4.960	5.064	5 1/4
7 1/4 RH&LH	.5375	1.380	1.038	.772	33°24'	4.962	5.170	5 1/4
9 2/3 RH&LH	.5375	1.380	1.038	.706	26°19'	4.962	5.234	5 1/4
15 1/2 RH&LH	.495	1.432	1.116	.764	15°46'	4.884	5.176	5 1/4
20 1/2	.3833	1.241	.997	.719	13°45'	5.003	5.233	5 1/4
24 1/2 RH&LH	.3205	1.224	1.020	.784	11°19'	4.980	5.176	5 1/4
30 RH&LH	.5091	1.463	1.139	.757	8°06'	4.861	5.179	5 1/4
40	.3929	1.248	.998	.702	7°09'	5.002	5.248	5 1/4
50	.3143	1.198	.998	.760	5°43'	5.002	5.200	5 1/4
60 RH&LH	.2658	1.092	.924	.724	5°14'	5.076	5.242	5 1/4
70	.2241	1.148	1.006	.836	4°03'	4.994	5.136	5 1/4

## Center Distance 3.500" Worms

## Face Width 1 1/4" Gears

Actual Ratio	Circ. Pitch	Out. Dia.	Pitch. Dia.	Root. Dia.	Lead Angle	Pitch. Dia.	Throat Dia.	Out. Dia.
5 1/6 RH&LH	.5780	1.656	1.288	1.068	40°36'	5.712	5.876	6 3/16
7 1/4 RH&LH	.6282	1.600	1.200	.936	33°41'	5.800	5.998	6 3/16
9 2/3 RH&LH	.6126	1.754	1.364	.966	23°13'	5.636	5.962	6 3/16
12 1/2	.7166	1.767	1.311	1.001	19°11'	5.689	5.913	6 3/16
14 1/2	.6026	1.821	1.437	1.005	14°57'	5.563	5.921	6 3/16
15 1/2	.5718	1.729	1.365	.955	14°56'	5.635	5.975	6 3/16
20 1/2 RH&LH	.4398	1.540	1.260	.940	12°32'	5.740	6.006	6 3/16
24 1/2 RH&LH	.3676	1.521	1.287	1.015	10°18'	5.713	5.939	6 3/16
30 RH&LH	.5874	1.777	1.403	.961	7°35'	5.597	5.965	6 3/16
40 RH&LH	.4430	1.622	1.340	1.006	6°0'	5.660	5.938	6 3/16
50	.3613	1.495	1.265	.991	5°12'	5.735	5.963	6 3/16
60	.3016	1.440	1.248	1.020	4°24'	5.752	5.942	6 3/16
70 RH&LH	.2576	1.394	1.230	1.034	3°49'	5.770	5.934	6 3/16

# Worm and Gear Data

## Center Distance 4.000" Worms

## Face Width 1 1/2" Gears

Actual Ratio	Circ. Pitch	Out. Dia.	Pitch. Dia.	Root. Dia.	Lead Angle	Pitch. Dia.	Throat Dia.	Out. Dia.
5 1/6 RH&LH	.6629	1.881	1.459	1.179	40°57'	6.541	6.757	7 1/8
7 1/4 RH&LH	.7195	1.816	1.358	1.016	34°00'	6.642	6.908	7 1/8
9 2/3	.7193	1.818	1.360	.918	26°48'	6.640	7.000	7 1/8
11 2/3	.5914	1.787	1.411	1.019	21°49'	6.589	6.911	7 1/8
12 2/3	.5455	1.750	1.402	1.034	20°23'	6.598	6.902	7 1/8
14 2/3	.4808	1.568	1.262	.936	19°59'	6.738	7.006	7 1/8
15 1/2 RH&LH	.6691	1.824	1.398	.928	16°57'	6.602	6.990	7 1/8
17 1/2	.5938	1.648	1.370	.948	15°25'	6.630	6.980	7 1/8
20 1/2 RH&LH	.5050	1.643	1.317	.947	13°43'	6.683	6.989	7 1/8
24 1/2	.4336	1.518	1.242	.926	12°32'	6.758	7.020	7 1/8
27 1/2	.3810	1.572	1.330	1.048	10°20'	6.670	6.904	7 1/8
30 RH&LH	.6882	1.862	1.424	.910	8°45'	6.576	7.004	7 1/8
35	.5874	1.777	1.403	.961	7°35'	6.597	6.965	7 1/8
36	.5750	1.777	1.411	.979	7°24'	6.589	6.949	7 1/8
40	.5245	1.655	1.321	.927	7°12'	6.679	7.007	7 1/8
46	.4487	1.716	1.430	1.090	5°42'	6.570	6.854	7 1/8
48	.4375	1.594	1.316	.986	6°02'	6.684	6.958	7 1/8
50 RH&LH	.4286	1.451	1.179	.857	6°36'	6.821	7.089	7 1/8
60 RH&LH	.3594	1.364	1.136	.864	5°45'	6.864	7.090	7 1/8
70	.3028	1.445	1.253	1.023	4°24'	6.747	6.939	7 1/8

## Center Distance 5.000" Worms

## Face Width 1 5/8" Gears

Actual Ratio	Circ. Pitch	Out. Dia.	Pitch. Dia.	Root. Dia.	Lead Angle	Pitch. Dia.	Throat Dia.	Out. Dia.
5 1/6	.8387	2.270	1.736	1.406	42°42'	8.264	8.514	8 7/8
7 1/4 RH&LH	.8984	2.280	1.708	1.274	33°49'	8.292	8.630	8 7/8
9 2/3 RH&LH	.8985	2.278	1.706	1.154	26°42'	8.294	8.744	8 7/8
11 2/3	.7381	2.247	1.777	1.285	21°38'	8.223	8.627	8 7/8
12 2/3	.6912	2.090	1.650	1.190	21°48'	8.350	8.728	8 7/8
15 1/2 RH&LH	.8482	2.170	1.630	1.042	18°20'	8.370	8.856	8 7/8
18 1/2	.7100	2.090	1.638	1.130	15°25'	8.362	8.732	8 7/8
20 1/2 RH&LH	.6408	2.045	1.637	1.173	14°00'	8.363	8.747	8 7/8
24 1/2	.5403	1.916	1.572	1.176	12°21'	8.428	8.756	8 7/8
27 1/2	.4792	1.917	1.611	1.255	10°43'	8.389	8.685	8 7/8
29 1/2	.4493	1.858	1.572	1.238	10°19'	8.428	8.706	8 7/8
36	.7250	2.154	1.692	1.146	7°46'	8.308	8.764	8 7/8
40 RH&LH	.6600	2.016	1.596	1.100	7°30'	8.404	8.816	8 7/8
48	.5556	1.865	1.511	1.091	6°41'	8.489	8.839	8 7/8
50	.5313	1.883	1.545	1.143	6°15'	8.455	8.789	8 7/8
60 RH&LH	.4487	1.716	1.430	1.090	5°42'	8.570	8.854	8 7/8
70	.3786	1.805	1.565	1.278	4°24'	8.435	8.675	8 7/8
100	.2692	1.588	1.416	1.211	3°28'	8.584	8.755	8 7/8



# Worm and Gear Data

## Center Distance 6.000" Worms

## Face Width 1 3/4" Gears

Actual Ratio	Circ. Pitch	Out. Dia.	Pitch. Dia.	Root. Dia.	Lead Angle	Pitch. Dia.	Throat Dia.	Out. Dia.
5 1/8 RH&LH	.7728	2.398	1.906	1.646	45°55'	10.094	10.286	10 5/8
7 2/5 RH&LH	.8571	2.451	1.905	1.479	35°36'	10.095	10.435	10 5/8
9 3/4	.8200	2.343	1.820	1.346	29°50'	10.180	10.564	10 7/8
11 2/3 RH&LH	.9069	2.457	1.879	1.383	24°46'	10.121	10.513	10 7/8
14 2/3	.7258	2.297	1.835	1.347	20°42'	10.165	10.567	10 7/8
20 1/2	.7692	2.451	1.961	1.405	14°01'	10.039	10.499	10 7/8
24 1/2 RH&LH	.6500	2.276	1.862	1.388	12°32'	10.138	10.532	10 7/8
29 1/2	.5404	2.236	1.892	1.492	10°18'	10.108	10.440	10 7/8
40 RH&LH	.7948	2.386	1.880	1.282	7°40'	10.120	10.618	10 7/8
45	.7000	2.442	1.998	1.472	6°20'	10.002	10.440	10 5/8
48	.6629	2.321	1.899	1.399	6°20'	10.101	10.517	10 7/8
50	.6377	2.257	1.851	1.369	6°15'	10.149	10.551	10 7/8
60 RH&LH	.5385	2.056	1.714	1.308	5°43'	10.286	10.624	10 7/8
70	.4651	1.934	1.636	1.282	5°10'	10.364	10.660	10 7/8

## Center Distance 7.000" Worms

## Face Width 1 7/8" Gears

Actual Ratio	Circ. Pitch	Out. Dia.	Pitch. Dia.	Root. Dia.	Lead Angle	Pitch. Dia.	Throat Dia.	Out. Dia.
5 1/8	.8984	2.860	2.288	1.972	45°00'	11.712	11.946	12 1/4
7 2/5 RH&LH	1.0000	2.859	2.223	1.721	35°36'	11.777	12.175	12 1/2
8 3/5	.8632	2.750	2.200	1.738	32°00'	11.800	12.168	12 1/2
9 3/4 RH&LH	.9545	2.758	2.150	1.594	29°29'	11.850	12.300	12 1/2
14 2/3	.8451	2.702	2.164	1.592	20°27'	11.836	12.306	12 1/2
19 1/2	.9456	2.860	2.258	1.580	14°56'	11.742	12.304	12 1/2
20 1/2	.8984	2.847	2.275	1.627	14°07'	11.725	12.263	12 1/2
24 1/2 RH&LH	.7571	2.673	2.191	1.637	12°24'	11.809	12.269	12 1/2
29 1/2 RH&LH	.6375	2.434	2.028	1.558	11°19'	11.972	12.362	12 1/2
35 1/2	.5404	2.236	1.892	1.492	10°18'	12.108	12.440	12 1/2
40 RH&LH	.9298	2.753	2.161	1.459	7°48'	11.839	12.419	12 1/2
50 RH&LH	.7444	2.626	2.152	1.590	6°17'	11.848	12.316	12 1/2
60	.6286	2.396	1.996	1.520	5°43'	12.004	12.400	12 1/2
70 RH&LH	.5373	2.366	2.028	1.626	4°49'	11.972	12.308	12 1/2
80	.4681	2.384	2.086	1.732	4°05'	11.914	12.210	12 1/2

# Worm and Gear Data

## Center Distance 8.000" Worms

## Face Width 2" Gears

Actual Ratio	Circ. Pitch	Out. Dia.	Pitch. Dia.	Root. Dia.	Lead Angle	Pitch. Dia.	Throat Dia.	Out. Dia.
5 1/8 RH&LH	1.0273	3.270	2.616	2.254	45°00'	13.384	13.654	14
7 2/5 RH&LH	1.1429	3.268	2.540	1.966	35°36'	13.460	13.916	14 3/8
9 3/4 RH&LH	1.0938	3.120	2.422	1.792	29°54'	13.578	14.090	14 3/8
11 2/3 RH&LH	1.2121	3.281	2.509	1.893	24°47'	13.491	14.017	14 3/8
14 2/3 RH&LH	.9666	3.077	2.461	1.809	20°34'	13.539	14.075	14 3/8
16 2/3 RH&LH	.8437	3.109	2.571	1.949	17°24'	13.966	13.966	14 1/4
17 0/3	.8387	2.937	2.403	1.823	18°26'	13.597	14.075	14 3/8
20 1/2 RH&LH	1.0250	3.275	2.623	1.883	13°58'	13.377	13.991	14 3/8
24 1/2	.8666	3.034	2.482	1.848	12°32'	13.518	14.044	14 3/8
25 1/2	.8281	3.084	2.556	1.946	11°39'	13.444	13.971	14.234
29 1/2 RH&LH	.7381	2.608	2.138	1.612	12°24'	13.862	14.304	14 3/8
40	1.0667	3.097	2.419	1.621	7°59'	13.581	14.245	14 3/8
50	.8519	2.984	2.442	1.798	6°20'	13.558	14.094	14 3/8
59	.7187	2.959	2.502	1.972	5°14'	13.498	13.956	14 3/16
60 RH&LH	.7179	2.746	2.288	1.744	5°42'	13.712	14.166	14 3/8
70 RH&LH	.6154	2.686	2.288	1.814	4°54'	13.712	14.108	14 3/8

## Center Distance 9.000" Worms

## Face Width 2 1/4" Gears

Actual Ratio	Circ. Pitch	Out. Dia.	Pitch. Dia.	Root. Dia.	Lead Angle	Pitch. Dia.	Throat Dia.	Out. Dia.
5 1/8	1.1529	3.670	2.936	2.530	45°00'	15.064	15.366	15 7/8
5 5/6	1.3684	3.597	2.725	2.333	43°50'	15.275	15.541	16
7 2/6 RH&LH	1.0870	3.468	2.776	2.248	36°47'	15.224	15.640	15 7/8
9 3/4	1.2284	3.532	2.750	2.036	29°38'	15.250	15.828	16 1/8
14 2/3 RH&LH	1.0870	3.468	2.776	2.042	20°30'	15.224	15.828	16 1/8
20 1/2 RH&LH	1.1529	3.688	2.954	2.120	13°57'	15.046	15.736	16 1/8
24 1/2	.9740	3.429	2.809	2.097	12°27'	15.191	15.781	16 1/8
29 1/2	.8200	3.122	2.600	1.996	11°21'	15.400	15.902	16 1/8
36	1.3300	3.724	3.066	2.068	7°52'	14.934	15.764	16
40	1.1970	3.522	2.760	1.862	7°52'	15.240	15.988	16 1/8
50 RH&LH	.9583	3.358	2.748	2.024	6°20'	15.252	15.854	16 1/8
60	.8077	3.088	2.574	1.964	5°42'	15.426	15.934	16 1/8
70 RH&LH	.6912	3.597	2.600	2.333	4°50'	15.275	15.541	16
80	.6094	2.910	2.522	2.046	4°24'	15.478	15.864	16

# Worm and Gear Data

## Center Distance 10.000" Worms

## Face Width 2 1/2" Gears

Actual Ratio	Circ. Pitch	Out. Dia.	Pitch. Dia.	Root. Dia.	Lead Angle	Pitch. Dia.	Throat Dia.	Out. Dia.
5 1/8 RH&LH	1.2818	4.080	3.264	2.812	45°00'	16.736	17.072	17 3/8
7 2/6 RH&LH	1.2083	3.846	3.076	2.492	36°53'	16.294	17.386	17 3/8
8 3/5	1.2375	3.841	3.053	2.535	32°49'	16.947	17.333	17 7/8
9 3/4 RH&LH	1.3654	3.920	3.050	2.258	29°41'	16.950	17.592	17 7/8
12 1/4 RH&LH	1.0833	3.795	3.105	2.407	23°58'	16.895	17.467	17 7/8
14 2/3 RH&LH	1.2083	3.846	3.076	2.260	20°34'	16.924	17.596	17 7/8
15 2/3	1.1309	3.780	3.060	2.288	19°26'	16.940	15.578	17 7/8
20 1/2 RH&LH	1.2826	4.078	3.262	2.336	14°03'	16.738	17.506	17 7/8
24 1/2 RH&LH	1.0833	3.794	3.104	2.312	12°32'	16.896	17.554	17 7/8
29 1/2	.9107	3.476	2.896	2.224	11°19'	17.104	17.662	17 7/8
32 1/2 RH&LH	.8378	3.200	2.667	2.049	11°18'	17.333	17.846	17 7/8
35 1/2	.7662	3.171	2.683	2.115	10°18'	17.317	17.789	17 7/8
39 1/2	.6842	3.216	2.780	2.268	8°55'	17.220	17.646	17 7/8
40	1.3300	3.916	3.066	2.068	7°52'	16.934	17.764	17 7/8
47	1.1309	3.780	3.060	2.208	6°43'	16.940	17.650	17 7/8
50 RH&LH	1.0645	3.736	3.058	2.254	6°19'	16.942	17.612	17 7/8
60	.8974	3.432	2.860	2.180	5°42'	17.140	17.706	17 7/8
70 RH&LH	.7667	3.404	2.918	2.338	4°47'	17.082	17.564	17 7/8
80	.6757	3.230	2.800	2.286	4°24'	17.200	17.678	17 7/8

## Center Distance 12.000" Worms

## Face Width 3" Gears

Actual Ratio	Circ. Pitch	Out. Dia.	Pitch. Dia.	Root. Dia.	Lead Angle	Pitch. Dia.	Throat Dia.	Out. Dia.
5 1/9 RH&LH	1.3949	4.440	3.552	3.144	48°22'	20.448	20.738	21
6 5/6	1.5625	4.597	3.603	3.025	39°40'	20.397	20.823	21
7 2/6	1.4503	4.610	3.688	2.988	36°54'	20.302	20.864	21
9 3/4	1.6389	4.699	3.655	2.705	29°43'	20.345	21.113	21 5/8
11 1/4	1.4300	4.414	3.504	2.638	27°27'	20.496	21.202	21 5/8
12 1/4	1.3214	4.210	3.368	2.628	26°34'	20.632	21.222	21 5/8
13 1/3	1.5959	4.699	3.683	2.681	22°29'	20.317	21.179	21 5/8
14 2/3 RH&LH	1.4503	4.612	3.688	2.708	20°35'	20.312	21.118	21 5/8
20 1/2 RH&LH	1.5550	4.689	3.699	2.585	14°59'	20.301	21.223	21 5/8
24 1/2 RH&LH	1.3000	4.552	3.724	2.774	12°32'	20.276	21.064	21 5/8
29 1/2 RH&LH	1.0933	4.163	3.467	2.663	11°21'	20.533	21.201	21 5/8
40 RH&LH	1.5960	4.696	3.680	2.732	7°52'	20.320	21.066	21 5/8
50 RH&LH	1.2787	4.463	3.649	2.683	6°22'	20.351	21.155	21 5/8
60	1.0776	4.106	3.420	2.604	5°44'	20.580	21.258	21 5/8
70	.9299	3.878	3.282	2.572	5°09'	20.718	21.310	21 5/8
80	.8200	3.654	3.132	2.510	4°46'	20.868	21.836	21 5/8

# Worm and Gear Data

## Center Distance 14.000" Worms

## Face Width 3 1/4" Gears

Actual Ratio	Circ. Pitch	Out. Dia.	Pitch. Dia.	Root. Dia.	Lead Angle	Pitch. Dia.	Throat Dia.	Out. Dia.
5 1/10	1.4667	5.137	4.203	3.763	48°01'	23.797	24.113	24 3/4
6 5/8	1.4200	4.972	4.068	3.568	41°38'	23.932	24.298	24 3/4
7 3/7 RH&LH	1.4604	4.766	3.836	3.250	40°19'	24.164	24.608	25 1/4
9 4/5	1.5294	5.114	4.140	3.362	30°28'	23.860	24.470	25
14 3/4	1.2750	4.872	4.060	3.214	21°48'	23.940	24.636	25 1/4
15 1/4	1.2315	4.851	4.067	3.241	21°05'	23.933	24.613	25
16 1/3	1.5333	5.026	4.050	3.006	19°52'	23.950	24.810	25 1/4
16 2/3	1.5051	5.030	4.072	3.044	19°26'	23.928	24.776	25 1/4
19 2/3	1.2745	4.872	4.060	3.160	16°42'	23.940	24.684	25 1/4
24 1/2	1.5294	5.114	4.140	3.028	13°14'	23.860	24.782	25 1/4
26 1/2	1.4200	4.972	4.068	3.030	12°32'	23.932	24.794	25 1/4
29 1/2 RH&LH	1.2750	4.872	4.060	3.120	11°19'	23.940	24.720	25 1/4
39 1/2 RH&LH	.9615	4.437	3.825	3.107	9°5'	24.175	24.771	25 1/4
50	1.5057	5.030	4.072	2.938	6°43'	23.928	24.872	25 1/4
60 RH&LH	1.2564	4.800	4.000	3.048	5°43'	24.000	24.792	25 1/4
70	1.0833	4.571	3.881	3.059	5°05'	24.119	24.803	25 1/4
79	.9615	4.437	3.825	3.095	4°34'	24.175	24.783	25 1/4

## Center Distance 17.000" Worms

## Face Width 3 3/4" Gears

Actual Ratio	Circ. Pitch	Out. Dia.	Pitch. Dia.	Root. Dia.	Lead Angle	Pitch. Dia.	Throat Dia.	Out. Dia.
5 1/10	1.7800	6.237	5.103	4.569	48°01'	28.897	29.281	30
6 3/8	1.7800	6.238	5.104	4.374	41°36'	28.896	29.458	30 1/4
7 3/7	1.7619	6.020	4.900	4.150	38°40'	29.100	29.676	30 1/2
8 2/7	1.5555	6.200	5.208	4.384	33°41'	28.792	29.450	30
9 1/7	1.4350	5.685	4.771	4.015	33°50'	29.229	29.833	30 1/2
9 4/5	1.8571	6.206	5.024	4.082	30°28'	28.976	29.714	30 1/2
12 3/4	1.7949	6.004	4.862	3.730	25°11'	29.138	30.064	30
14 3/4	1.5500	5.916	4.930	3.902	21°48'	29.070	29.914	30 1/2
16 1/3 RH&LH	1.8518	6.332	5.154	3.882	18°55'	28.846	29.896	30 1/2
19 2/3	1.5746	5.916	4.930	3.840	16°42'	29.070	29.972	30 1/2
21 1/3	1.4333	5.712	4.800	3.782	15°55'	29.200	30.042	30 1/2
22 1/3	1.3666	5.764	4.894	3.914	14°56'	29.106	29.918	30 1/2
24 1/2	1.8571	6.206	5.024	3.674	13°14'	28.976	30.096	30 1/2
29 1/2	1.5500	5.916	4.930	3.788	11°19'	29.070	30.018	30 1/2
39 1/2 RH&LH	1.1951	5.394	4.650	3.778	9°17'	29.350	30.076	30 1/2
50 RH&LH	1.8250	6.101	4.939	3.563	6°43'	29.061	30.207	30 1/2
60 RH&LH	1.5250	5.832	4.860	3.704	5°43'	29.140	30.102	30 1/2
70	1.3044	5.810	4.980	3.990	4°46'	29.020	29.844	30 1/2

# Worm and Gear Data

## Center Distance 18.000" Worms

## Face Width 4" Gears

Actual Ratio	Circ. Pitch	Out. Dia.	Pitch. Dia.	Root. Dia.	Lead Angle	Pitch. Dia.	Throat Dia.	Out. Dia.
6 4/7	2.0851	6.806	5.478	4.798	40°19'	30.522	31.000	32
7 3/5	2.5125	7.200	5.600	4.560	35°32'	30.400	31.244	32
8 3/5	2.2145	7.058	5.646	4.426	31°59'	30.354	31.336	32
9 4/5 RH&LH	1.9666	6.573	5.321	4.321	30°28'	30.679	31.463	32
12 1/4 RH&LH	2.0000	6.446	5.172	3.932	26°13'	30.829	31.840	32
14 3/4 RH&LH	1.6250	6.475	5.439	4.345	20°51'	30.561	31.461	32
17 1/3 RH&LH	1.8333	6.705	5.539	4.259	17°32'	30.461	31.619	32
24 1/2	1.9500	6.831	5.589	4.179	12°32'	30.411	31.591	32
26 1/2	1.8333	6.705	5.539	4.195	11°57'	30.461	31.577	32
32 1/2	1.4828	6.490	5.546	4.442	9°40'	30.454	31.372	32
35 1/2	1.3750	6.337	5.463	4.439	9°05'	30.534	31.389	32
44	2.1500	7.184	5.814	4.194	6°43'	30.186	31.534	32
53	1.8065	6.613	5.463	4.097	6°01'	30.537	31.675	32
62	1.5357	6.724	5.746	4.580	4°52'	30.254	31.226	32
70	1.3696	6.322	5.450	4.410	4°34'	30.550	31.316	32

## Center Distance 20.000" Worms

## Face Width 4" Gears

Actual Ratio	Circ. Pitch	Out. Dia.	Pitch. Dia.	Root. Dia.	Lead Angle	Pitch. Dia.	Throat Dia.	Out. Dia.
5 1/10	2.1111	7.056	5.712	5.142	49°38'	34.288	34.684	35 1/2
7 3/7	2.0857	6.806	5.478	4.798	40°19'	34.522	35.000	36
9 4/5	2.2143	6.874	5.464	4.514	32°50'	34.536	35.250	36
11 2/5 RH&LH	1.9666	6.573	5.321	4.321	30°28'	34.679	35.463	36
14 3/4	1.8333	6.716	5.548	4.348	22°50'	34.452	35.436	36
19 2/3 RH&LH	1.8333	6.705	5.539	4.259	17°32'	34.461	35.519	36
24 1/2	2.2143	6.874	5.464	3.870	14°28'	34.536	35.856	36
27 1/2	1.9636	6.875	5.625	4.191	12°32'	34.375	35.565	36
29 1/2	1.8333	6.705	5.539	4.195	11°57'	34.461	35.517	36
32 1/2	1.6522	6.838	5.786	4.562	10°18'	34.214	35.232	36
36 1/2	1.4828	6.490	5.546	4.442	9°40'	34.454	35.372	36
39 1/2	1.3750	6.337	5.463	4.439	9°05'	34.537	35.389	36
50	2.1500	7.184	5.814	4.194	6°43'	34.186	35.534	36
60	1.8065	6.613	5.463	4.097	6°01'	34.537	35.675	36
70	1.5357	6.724	5.746	4.580	4°52'	34.254	35.226	36

# Worm and Gear Data

## Center Distance 21.837" Worms

## Face Width 5" Gears

Actual Ratio	Circ. Pitch	Out. Dia.	Pitch. Dia.	Root. Dia.	Lead Angle	Pitch. Dia.	Throat Dia.	Out. Dia.
6 1/9 RH&LH	2.0800	8.606	7.282	6.354	39°17'	36.392	37.116	37 3/4
6 5/8	2.1552	8.918	7.546	6.478	36°02'	36.128	36.974	37 3/4
7 2/7 RH&LH	2.2666	8.303	6.859	5.845	36°23'	36.815	37.679	38 3/8
7 6/7	2.0645	8.870	7.556	6.402	31°20'	36.118	37.048	37 3/4
8 5/6 RH&LH	2.1552	8.918	7.546	6.286	28°37'	36.128	37.166	37 3/4
10 1/4	2.8235	8.550	6.750	5.200	28°04'	39.924	38.156	39 1/4
11 1/4	2.5714	8.584	6.950	5.334	25°12'	36.724	38.044	39 1/4
11 3/4 RH&LH	2.4375	8.739	7.187	5.605	23°23'	36.487	37.785	38 9/16
13 1/4 RH&LH	2.1750	8.996	7.612	6.134	19°59'	36.062	37.280	37 3/4
13 2/3 RH&LH	2.8333	8.501	6.697	4.821	22°01'	36.977	38.519	37 3/4
17 2/3	2.1458	9.050	7.684	6.146	14°56'	35.990	37.264	37 3/4
19 2/3 RH&LH	1.9200	8.860	7.638	6.246	13°30'	36.036	37.190	37 3/4
22 1/3	1.7179	8.615	7.521	6.263	12°18'	36.153	37.197	37 3/4
23 1/3	1.6222	8.514	7.482	6.290	11°41'	36.192	37.182	37 3/4
26 1/2	2.1552	8.918	7.546	6.106	10°18'	36.128	37.298	37 3/4
35 1/2	1.6053	8.687	7.665	6.459	7°36'	36.009	37.013	37 3/4
45	2.5352	9.080	7.666	6.268	6°01'	36.008	37.204	37 3/4
50	2.2500	9.296	7.864	6.158	5°12'	35.810	37.230	37 3/4
63	1.8065	8.912	7.762	6.388	4°14'	35.912	37.056	37 3/4
71	1.6061	8.431	7.409	6.187	3°57'	36.165	37.181	37 3/4

## Center Distance 24.000" Worms

## Face Width 5 1/2" Gears

Actual Ratio	Circ. Pitch	Out. Dia.	Pitch. Dia.	Root. Dia.	Lead Angle	Pitch. Dia.	Throat Dia.	Out. Dia.
4 1/12 RH&LH	2.5217	10.238	8.632	7.882	48°09'	39.368	39.904	41
5 1/10 RH&LH	2.4500	9.750	8.190	7.266	43°36'	39.810	40.510	41 1/2
6 8/9 RH&LH	2.0800	8.606	7.284	6.354	39°17'	40.718	41.442	42
7 3/8	2.1552	8.918	7.546	6.478	36°03'	40.454	41.300	42
7 6/7	2.3571	8.250	6.750	5.810	37°52'	41.250	41.990	42 1/2
8 1/7 RH&LH	2.2666	8.303	6.859	5.895	36°23'	41.141	42.005	42 1/2
9 5/6 RH&LH	2.1552	8.918	7.546	6.268	28°37'	40.454	41.492	42
10 1/5 RH&LH	2.4375	10.075	8.525	6.975	24°27'	39.475	40.745	41 1/2
14 3/4 RH&LH	2.1750	8.996	7.612	6.134	19°59'	40.338	41.606	42
17 2/3	2.3750	9.450	7.938	6.252	15°57'	40.062	41.458	42
19 2/3	2.1458	9.050	7.684	6.146	14°56'	40.316	41.590	42
22 1/3	1.9200	9.000	7.800	6.432	13°14'	40.200	41.408	42
24 2/3	1.7179	8.615	7.521	6.263	12°18'	40.479	41.523	42
26 1/2	2.3750	9.450	7.938	6.182	10°47'	40.062	41.552	42
29 1/2	2.1552	8.918	7.546	6.106	10°18'	40.454	41.624	42
39 1/2	1.6053	8.687	7.665	6.459	7°36'	40.335	41.339	42
41	3.1250	9.206	7.216	5.068	7°51'	40.784	42.738	43 1/2
44 1/2	1.4706	7.254	6.318	5.238	8°26'	41.682	42.618	43
50	2.5555	8.948	7.320	5.720	6°20'	40.680	42.130	42 3/4
60	2.1017	9.198	7.860	6.266	4°52'	40.140	41.468	42
70	1.8065	8.912	7.762	6.388	4°14'	40.238	41.382	42
89	1.4231	8.606	7.700	6.618	3°22'	40.300	41.202	42

# Worm and Gear Data

## Center Distance 26.500" Worms

## Face Width 5 3/4 - 6 3/4" Gears

Actual Ratio	Circ. Pitch	Out. Dia.	Pitch Dia.	Root Dia.	Lead Angle	Pitch Dia.	Throat Dia.	Out. Dia.
4 1/12	2.7188	11.831	10.595	9.209	44°26'	42.405	43.641	44 1/4
5 7/10	2.4500	9.750	8.190	7.266	43°6'	44.810	45.510	46
6 3/8 RH&LH	2.7500	10.074	8.322	7.246	40°6'	44.678	45.486	46
7 3/8 RH&LH	2.3780	9.841	8.327	7.149	36°2'	44.673	45.651	46
7 7/9 RH&LH	2.0800	8.606	7.282	6.354	39°17'	45.718	46.442	47
9 1/5 RH&LH	3.0857	9.820	7.856	6.476	32°0'	45.144	46.190	47
11 2/5 RH&LH	2.4375	10.075	8.525	6.975	24°27'	44.475	45.745	46
16 1/4 RH&LH	2.1750	8.996	7.612	6.134	19°59'	45.388	46.606	47
20 1/3	2.3750	9.450	7.938	6.252	15°57'	45.062	46.574	47
21 1/3	2.1929	9.772	8.376	6.864	14°2'	44.624	45.936	47
22 1/3	2.1458	9.050	7.684	6.146	14°56'	45.316	46.590	47
23 2/3 LH	1.9688	9.505	8.253	6.851	12°50'	44.747	45.999	47
24 1/2 RH&LH	2.8966	9.341	7.837	6.053	13°14'	45.163	46.709	47
29 1/3	1.6667	8.514	7.482	6.290	12°1'	45.518	46.508	47
30 1/2 RH&LH	2.3414	10.058	8.568	6.836	9°52'	44.432	45.876	46
34 1/2	2.0500	9.780	8.476	6.944	8°45'	44.524	45.798	46
37 1/2	1.9777	8.612	7.380	5.940	9°41'	45.620	46.816	47
50	2.8000	10.247	8.465	6.551	6°0'	44.535	46.299	46 1/2
51	2.7419	9.840	8.294	6.620	6°1'	44.706	46.032	47
60	2.3125	9.936	8.464	6.850	4°58'	44.536	45.996	47
100	1.4231	8.606	7.700	6.618	3°22'	45.300	46.202	48 1/4

## Center Distance 27.000" Worms

## Face Width 5 3/4 - 6 3/4" Gears

Actual Ratio	Circ. Pitch	Out. Dia.	Pitch Dia.	Root Dia.	Lead Angle	Pitch Dia.	Throat Dia.	Out. Dia.
4 7/11 RH&LH	2.7000	11.887	10.169	9.119	42°55'	43.831	44.629	45 1/4
5 7/9 RH&LH	2.7469	10.280	8.532	7.532	42°41'	45.468	46.290	47
6 5/8 RH&LH	2.7500	10.074	8.322	7.246	40°06'	45.678	46.486	47 1/2
7 5/8 RH&LH	2.3781	9.841	8.327	7.149	36°01'	45.673	46.651	47 1/2
8 5/6 RH&LH	2.7428	10.258	8.512	6.994	31°36'	45.488	46.708	47 1/2
9 2/5	3.0857	9.820	7.856	6.476	32°00'	46.144	47.190	48
11 4/5 RH&LH	2.4375	10.075	8.525	6.975	24°27'	45.475	46.745	47 1/2
15 1/4	2.3750	9.440	7.930	6.334	20°51'	46.070	47.384	48
16 3/4 RH&LH	2.1750	8.996	7.612	6.134	19°59'	46.388	47.606	48
17 1/3	2.7500	10.074	8.322	6.398	17°32'	45.678	47.268	48
19 1/3	2.4848	9.744	8.120	6.324	16°17'	45.880	47.366	48
19 2/3 LH	2.4688	9.207	7.637	5.917	17°09'	46.363	47.933	48 1/4
21 2/3	2.1929	9.772	8.376	6.782	14°02'	45.624	46.936	47 1/2
22 2/3	2.1538	9.450	8.100	6.570	14°15'	45.900	47.170	48
24 1/3	2.0303	9.034	7.766	6.326	14°01'	46.234	47.428	48
29 1/2	2.4412	9.712	8.158	6.354	10°47'	45.842	47.340	48
30 1/2 RH&LH	2.3414	10.058	8.568	6.836	9°52'	45.432	46.876	47 1/2
35 1/2 RH&LH	2.0500	9.780	8.476	6.944	8°45'	45.524	46.798	47 1/2
37 1/2 RH&LH	1.9231	9.364	8.140	6.744	8°33'	45.860	47.058	47 7/8
45	3.1948	9.970	8.136	6.216	7°08'	45.864	47.580	48
51	2.8000	10.247	8.465	6.551	6°00'	45.535	47.299	48
53	2.7018	10.105	8.385	6.341	5°51'	45.615	47.317	48
62	2.3125	9.936	8.464	6.850	4°58'	45.536	46.996	47 1/2

# Worm and Gear Data

## Center Distance 28.000" Worms

## Face Width 5 3/4" - 6 1/2" Gears

Actual Ratio	Circ. Pitch	Out. Dia.	Pitch. Dia.	Root. Dia.	Lead Angle	Pitch. Dia.	Throat Dia.	Out. Dia.
6 7/8	2.7500	10.074	8.322	7.246	40°6'	47.678	48.486	49 1/2
7 7/8 RH&LH	2.3781	9.841	8.327	7.149	36°2'	47.673	48.651	50
9 1/6	2.7428	10.258	8.512	6.994	31°36'	47.488	48.708	49 1/2
9 4/5	3.0857	9.820	7.856	6.476	32°0'	48.144	49.190	50 1/8
13 1/4	2.7500	10.074	8.322	6.522	22°50'	47.678	49.156	50
16 2/3	2.9091	11.575	9.723	7.771	15°57'	46.227	47.937	49
17 2/3	2.7500	10.074	8.322	6.398	17°32'	47.678	49.268	50
19 2/3	2.6078	9.744	8.120	6.324	17°3'	47.880	49.366	50
22 2/3	2.1929	9.772	8.376	6.792	14°2'	47.624	48.936	49 1/2
23 2/3	2.1538	9.450	8.100	6.570	14°15'	47.900	49.170	49 3/4
25 1/3	2.0303	9.034	7.766	6.326	14°1'	48.234	49.428	50
26 1/2	2.7500	10.074	8.322	6.302	11°53'	47.678	49.430	50 1/4
31 1/3	1.6667	8.514	7.480	6.290	12°1'	48.518	49.508	50
36 1/2	2.0500	9.780	8.476	6.944	8°45'	47.524	48.798	49 1/2
39 1/2	1.9777	8.612	7.380	5.940	9°41'	48.620	49.816	50
40	3.6250	12.126	9.820	7.620	6°43'	46.180	48.230	49
47	3.1948	9.970	8.136	6.216	7°8'	47.864	49.580	50
56	2.7018	10.105	8.385	6.341	5°51'	47.615	49.317	50
65	2.3125	9.936	8.464	6.850	4°58'	47.536	48.996	50

## Center Distance 30.000" Worms

## Face Width 6" Gears

Actual Ratio	Circ. Pitch	Out. Dia.	Pitch. Dia.	Root. Dia.	Lead Angle	Pitch. Dia.	Throat Dia.	Out. Dia.
6 5/9 RH&LH	2.7469	10.280	8.532	7.532	42°41'	51.468	52.290	53
7 3/8 RH&LH	2.7500	10.074	8.322	7.246	40°06'	51.678	52.486	53 1/2
8 5/8 RH&LH	2.3781	9.841	8.327	7.149	36°01'	51.673	52.651	53 1/2
9 5/6 RH&LH	2.7428	10.258	8.512	6.994	31°36'	51.488	52.708	53 1/2
14 1/4 RH&LH	2.8646	9.804	7.980	6.456	24°34'	52.020	53.214	54 1/8
14 3/4	2.7500	10.074	8.322	6.522	22°50'	51.678	53.156	54
17 1/3	3.1205	10.330	8.344	6.390	19°39'	51.656	53.410	54
19 2/3	2.7500	10.074	8.322	6.398	17°32'	51.678	56.268	54
24 2/3	2.1929	9.772	8.376	6.782	14°02'	51.624	52.936	53 3/4
29 1/2	2.7500	10.074	8.322	6.302	11°53'	51.678	53.354	54
34 1/2 RH&LH	2.3414	10.058	8.568	6.836	9°52'	51.432	52.876	53 1/2
39 1/2	2.0500	9.780	8.476	6.944	8°45'	51.524	52.798	53 3/4
50	3.1667	11.586	9.570	7.404	6°00'	50.430	52.430	53 1/2
51	3.1948	9.970	8.136	6.216	7°08'	51.864	53.580	54
60	2.7018	10.105	8.385	6.341	5°51'	51.615	53.317	54
70	2.3125	9.936	8.464	6.850	4°58'	51.536	52.996	54



# Worm and Gear Data

## Center Distance 36.000" Worms

## Face Width 6 1/2" Gears

Actual Ratio	Circ. Pitch	Out. Dia.	Pitch. Dia.	Root. Dia.	Lead Angle	Pitch. Dia.	Throat Dia.	Out. Dia.
10 1/7 RH&LH	2.7742	11.038	9.272	7.806	33°41'	62.728	63.900	64 3/4
11 2/5 RH&LH	3.4888	11.378	9.158	7.502	31°13'	62.842	64.118	64 3/4
13 1/2	2.9777	11.376	9.480	7.640	26°34'	62.520	64.020	64 3/4
14 1/4 RH&LH	3.4375	11.771	9.581	7.389	24°34'	62.419	64.213	65 1/4
15 1/5	2.5854	11.110	9.464	7.790	23°30'	62.536	63.908	64 3/4
20 1/4	2.4194	11.165	9.625	7.937	17°45'	62.375	63.769	64 3/4
23 1/3 RH&LH	2.8105	11.641	9.851	7.843	15°14'	62.149	63.957	64 3/4
25 1/3	2.5854	11.110	9.464	7.606	14°37'	62.536	64.076	64 3/4
26 2/3	2.4545	11.058	9.496	7.722	13°52'	62.504	63.974	64 3/4
29 2/3	2.2051	10.881	9.477	7.865	12°32'	62.523	63.861	64 3/4
39 1/2	2.4848	11.074	9.492	7.640	9°28'	62.508	64.048	64 3/4
49 1/2	1.9846	10.744	9.480	7.988	7°36'	62.520	63.762	64 3/4
73	2.7419	9.840	8.294	6.620	6°01'	63.706	65.032	65 5/8
75	2.6182	11.000	9.333	7.540	5°06'	62.667	64.198	65

## Center Distance 42.000" Worms

## Face Width 7" Gears

Actual Ratio	Circ. Pitch	Out. Dia.	Pitch. Dia.	Root. Dia.	Lead Angle	Pitch. Dia.	Throat Dia.	Out. Dia.
10 1/8	2.8529	12.258	10.442	8.978	34°49'	73.558	74.722	75 3/4
14 1/6	2.7027	11.970	10.260	8.606	26°42'	73.740	75.194	75 3/4
22 3/4	2.5417	12.044	10.426	8.644	17°15'	73.574	75.046	75 3/4
25 1/3	3.0345	12.558	10.626	8.458	15°15'	73.374	75.168	75 3/4
29 2/3	2.5882	12.350	10.712	8.826	12°59'	73.288	74.852	75 3/4
34 1/2	3.3214	13.212	11.098	8.760	10°47'	72.902	74.942	75 3/4
39 1/2	2.9155	12.528	10.672	8.506	9°52'	73.328	75.128	75 3/4
49 1/2	2.3333	11.888	10.402	8.652	8°08'	73.598	75.054	75 3/4
59 1/2	1.9412	11.742	10.506	9.042	6°43'	73.494	74.712	75 3/4

## Center Distance 48.000" Worms

## Face Width 7 1/2" Gears

Actual Ratio	Circ. Pitch	Out. Dia.	Pitch. Dia.	Root. Dia.	Lead Angle	Pitch. Dia.	Throat Dia.	Out. Dia.
10 1/9	2.9565	12.233	10.351	9.029	39°17'	85.649	86.681	88
16 5/6	2.7027	11.970	10.260	8.606	26°42'	85.740	87.194	88
20 1/5	2.6705	11.800	10.200	8.448	22°37'	85.800	87.238	88
25 1/4	2.6705	11.800	10.200	8.352	18°26'	85.800	87.324	88
29 2/3	3.0345	12.558	10.626	8.458	15°15'	85.374	87.168	88
34 1/3	2.5882	12.350	10.712	8.826	12°59'	85.288	86.852	88
40 1/2	3.3214	13.312	11.098	8.760	10°47'	84.902	86.942	88
49 1/2	2.7174	12.110	10.380	8.254	9°28'	85.620	87.304	88
57 1/2	2.3333	11.888	10.402	8.652	8°08'	85.598	87.054	88
69 1/2	1.9412	11.742	10.506	9.042	6°43'	85.494	86.712	88

# Single and Double Extended Worm Assemblies with Fan

## 2" - 7" Center Distance

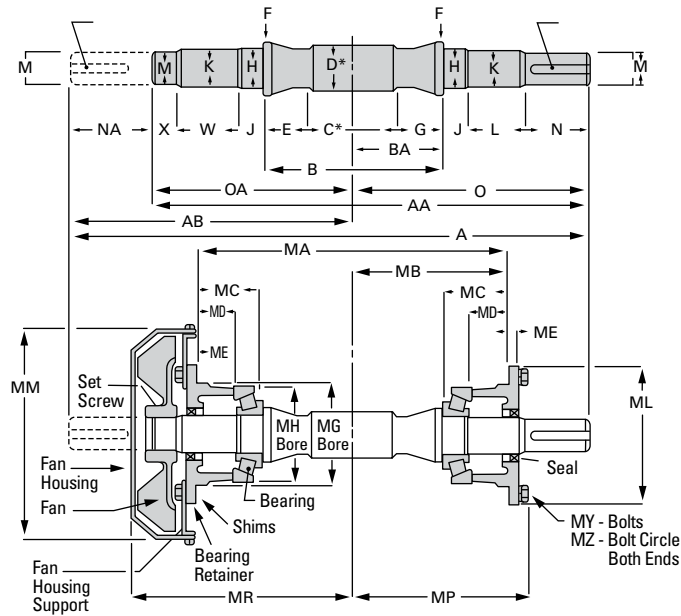

Note: All dimensions and specifications are subject to change without notice. Work only from certified prints.

Center Distance	A	AA	AB	B	BA	C*	D*	E	F	G	H	J	K	L	M	N	NA	O	OA	W	X	KEYWAY
2	10 3/8	9	5 7/8	3.505 3.495	1 3/4	1 7/8	1 1/4	25/37	1 1/16	27/32	.8452 .8447	3/4	.752 .748	11/16	.6875 .6870	15/16	1 3/8	4 1/2	4 1/2	1 1/16	15/16	3/16 x 3/32 x 1 7/32
2 1/2	12 1/4	9 15/16	6 7/8	3.680 3.870	1 15/16	1 7/8	1 1/4	15/16	1 1/8	1 1/16	.7515 .7510	13/16	.748 .745	7/8	.6875 .6870	1 3/4	2 5/16	5 3/8	4 9/16	1 3/16	5/8	3/16 x 3/32 x 1 11/16
3	13 15/16	11 1/2	7 13/16	4.630 4.620	2 5/16	2	1 1/2	15/16	1 1/2	15/16	1.1265 1.1260	7/8	1.002 .995	1 1/16	.8750 .8745	1 7/8	2 7/16	6 1/8	5 3/8	15/16	7/8	3/16 x 3/32 x 1 13/16
3 1/2	15 5/8	13 1/16	8 5/8	5.130 5.120	2 9/16	2 5/8	1 13/16	1 1/4	1 1/2	1 1/4	1.1265 1.1260	7/8	1.123 1.120	1 9/16	1.0000 .9995	2	2 9/16	7	6 1/16	1 3/4	7/8	1/4 x 1/8 x 1 1/16
4	17 9/16	14 11/16	9 13/16	5.880 5.870	2 15/16	3	1 15/16	17/16	1 3/4	1 7/16	1.3140 1.3135	1	1.252 1.247	1 3/4	1.1250 1.1245	2 1/16	2 7/8	7 3/4	6 15/16	2	1	1/4 x 1/8 x 2
5	19 11/16	16 3/8	10 15/16	7.130 7.120	3 9/16	3 1/4	2 5/16	1 15/16	2 1/4	1 15/16	1.7515 1.7510	1	1.502 1.495	1 7/8	1.3750 1.3745	2 5/16	3 5/8	8 3/4	7 5/8	2 1/16	1	5/16 x 5/32 x 2 1/4
6	22 7/8	19 1/4	12 5/8	8.380 8.370	4 3/16	3 1/2	2 1/2	2 7/16	2 1/2	2 7/16	1.8765 1.8760	1 7/32	1.752 1.748	2 5/32	1.500 1.499	2 11/16	3 5/8	10 1/4	9	2 19/32	1	3/8 x 3/16 x 2 5/8
7	25 3/8	21 1/8	13 7/8	8.755 8.745	4 3/8	4 1/4	2 7/8	2 1/4	2 9/16	2 1/4	1.8765 1.8760	1 7/32	1.752 1.748	2 25/32	1.625 1.624	3 1/8	4 1/4	11 1/2	9 5/8	3 1/32	1	3/8 x 3/16 x 3 1/16

\*Maximum varies with ratio

Center Distance	MA	MB	MC	MD	ME	MG	MH	ML	MM	MP	MR	MY	MZ	BEARING	SEAL	WIDTH
2	5.375 5.370	2 11/16	7/8	.255 .260	1/4	-	1.9687 1.9697	3 5/16	4 1/4	3 3/16	4 9/16	4-1/4	2 5/8	M12649 M12610	DH37B-1	1/4
2 1/2	6.375 6.370	3 3/16	1 1/16	.384 .382	1/4	2.1350 2.1362	2.1250 2.1262	3 5/16	4 1/4	3 11/16	5 1/16	4-1/4	2 5/8	21075 21212	DH37B-1	1/4
3	7.500 7.495	3 3/4	1 3/16	.447 .445	1/4	3.1350 3.1362	3.1250 3.1262	4 3/16	5 1/4	4 1/4	5 15/16	4-1/4	3 5/8	43112 43312	DH37C-1	1/4
3 1/2	8.875 8.870	4 7/16	1 5/8	.884 .882	5/16	3.1350 3.1362	3.1250 3.1262	4 7/16	5 1/4	5 1/16	6 5/8	4-5/16	3 3/4	43112 43312	DH37D-1	1/4
4	10.125 10.120	5 1/16	1 15/16	1.134 1.132	3/8	3.4943 3.4957	3.4843 3.4857	4 13/16	6 5/8	5 3/4	8	4-5/16	4 1/8	44131 44348	DH37E-1	1/4
5	11.625 11.620	5 13/16	1 15/16	1.072 1.070	3/8	4.3870 4.3884	4.3750 4.3764	5 11/16	7 3/8	6 3/8	8 5/8	4-5/16	5	55175 55437	DH37F-1	5/16
6	13.875 13.870	6 15/16	2 3/8	1.322 1.320	1/2	4.8850 4.8866	4.8750 4.8766	6 11/16	8 1/4	7 7/8	10 1/16	4-7/16	5 3/4	72187 72487	DH37G-1	5/16
7	15.125 15.120	7 9/16	2 13/16	1.759 1.757	1/2	4.8870 4.8886	4.8750 4.8766	6 11/16	10 3/8	8 1/2	10 3/4	4-7/16	5 3/4	72187 72487	DH37G-1	5/16

# Single and Double Extended Worm Assemblies without Fan

## 2" - 7" Center Distance

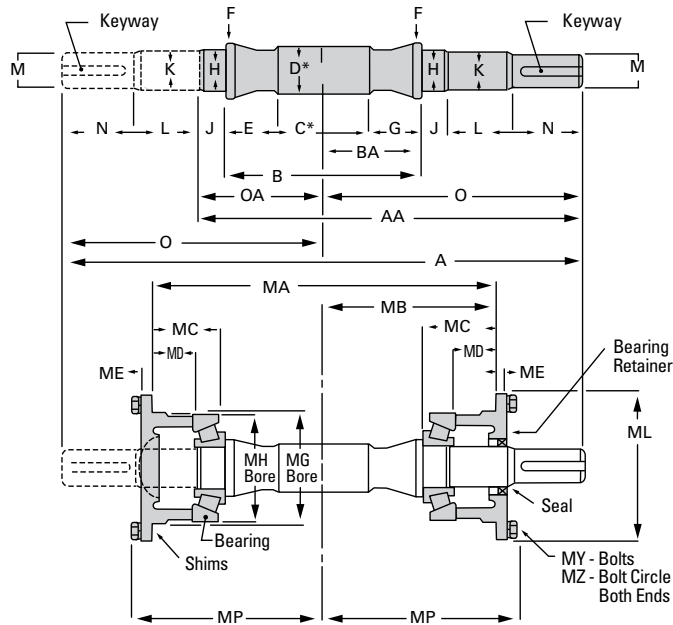

Note: All dimensions and specifications are subject to change without notice. Work only from certified prints.

Center Distance	A	AA	B	BA	C*	D*	E	F	G	H	J	K	L	M	N	O	OA	Keyway
2	9	7	3.505 3.495	1 3/4	17/8	1 1/4	25/32	1 1/16	27/32	.8452 .8447	3/4	.752 .748	11/16	.6875 .6870	1 5/16	4 1/2	2 1/2	3/16 x 3/32 x 1 7/32
2 1/2	10 3/4	8 1/8	3.880 3.870	1 15/16	1 7/8	1 1/4	15/16	1 1/8	1 1/16	.7515 .7510	13/16	.748 .745	7/8	.6875 .6870	13/4	5 3/8	2 3/4	3/16 x 3/32 x 1 11/16
3	12 1/4	9 5/16	4.630 4.620	2 5/16	2	1 1/2	1 5/16	1 1/2	1 5/16	1.1265 1.1260	7/8	1.002 .995	1 1/16	.8750 .8745	1 7/8	6/8	3 3/16	3/16 x 3/32 x 1 13/16
3 1/2	14	10 7/16	5.130 5.120	2 9/16	2 5/8	1 13/16	1 1/4	1 1/2	1 1/4	1.1265 1.1260	7/8	1.123 1.120	1 9/16	1.0000 .9995	2	7	3 7/16	1/4 x 1/8 x 1 15/16
4	15 1/2	11 11/16	5.880 5.870	2 15/16	3	1 15/16	1 7/16	1 3/4	1 7/16	1.3140 1.3135	1	1.252 1.247	1 3/4	1.1250 1.1245	2 1/16	7 3/4	3 15/16	1/4 x 1/8 X 2
5	17 1/2	13 5/16	7.130 7.120	3 9/16	3 1/4	2 5/16	1 15/16	2 1/4	1 15/16	1.7515 1.7510	1	1.502 1.495	1 7/8	1.3750 1.3745	2 5/16	8 3/4	4 9/16	5/16 x 5/32 x 2 1/4
6	20 1/2	15 21/32	8.380 8.370	4 3/16	3 1/2	2 1/2	2 7/16	2 1/2	2 7/16	1.8765 1.8760	1 7/32	1.752 1.748	2 5/32	1.500 1.499	2 11/16	10 1/4	5 13/32	3/8 x 3/16 x 2 5/8
7	23	17 3/32	8.755 8.745	4 3/8	4 1/4	2 7/8	2 1/4	2 9/16	2 1/4	1.8765 1.8760	1 7/32	1.752 1.748	2 25/32	1.625 1.624	3 1/8	11 1/2	5 19/32	3/8 x 3/16 X 3 1/16

Center Distance	MA	MB	MC	MD	ME	MG	MH	ML	MP	MY	MZ	Bearing	Seal	Width
2	5.375 5.370	2 11/16	7/8	.255 .260	1/4	-	1.9687 1.9697	3 5/16	3 3/16	4 - 1/4	2 5/8	M12649 M12610	DH37B-1	1/4
2 1/2	6.375 6.370	3 3/16	1 1/16	.384 .382	1/4	2.1350 2.1362	2.1250 2.1262	3 5/16	3 11/16	4 - 1/4	2 5/8	21075 21212	DH37B-1	1/4
3	7.500 7.495	3 3/4	1 3/16	.447 .445	1/4	3.1350 3.1362	3.1250 3.1262	4 3/16	4 1/4	4 - 1/4	3 5/8	43112 43312	DH37C-1	1/4
3 1/2	8.875 8.870	4 7/16	1 5/8	.884 .882	5/16	3.1350 3.1362	3.1250 3.1262	4 7/16	5 1/16	4 - 5/16	3 3/4	43112 43312	DH37D-1	1/4
4	10.125 10.120	5 1/16	1 15/16	1.134 1.132	3/8	3.4943 3.4957	3.4843 3.4857	4 13/16	5 3/4	4 - 5/16	4 1/8	44131 44348	DH37E-1	1/4
5	11.625 11.620	5 13/16	1 15/16	1.072 1.070	3/8	4.3870 4.3884	4.3750 4.3764	5 11/16	6 3/8	4 - 5/16	5	55175 55437	DH37F-1	5/16
6	13.875 13.870	6 15/16	2 3/8	1.322 1.320	1/2	4.8850 4.8866	4.8750 4.8766	6 11/16	7 7/8	4 - 7/16	5 3/4	72187 72487	DH37G-1	5/16
7	15.125 15.120	7 9/16	2 13/16	1.759 1.757	1/2	4.8870 4.8886	4.8750 4.8766	6 11/16	8 1/2	4 - 7/16	5 3/4	72187 72487	DH37G-1	5/16

# Single and Double Extended Worm Assemblies with Fan

## 8" -12" Center Distance

Note: All dimensions and specifications are subject to change without notice. Work only from certified prints.

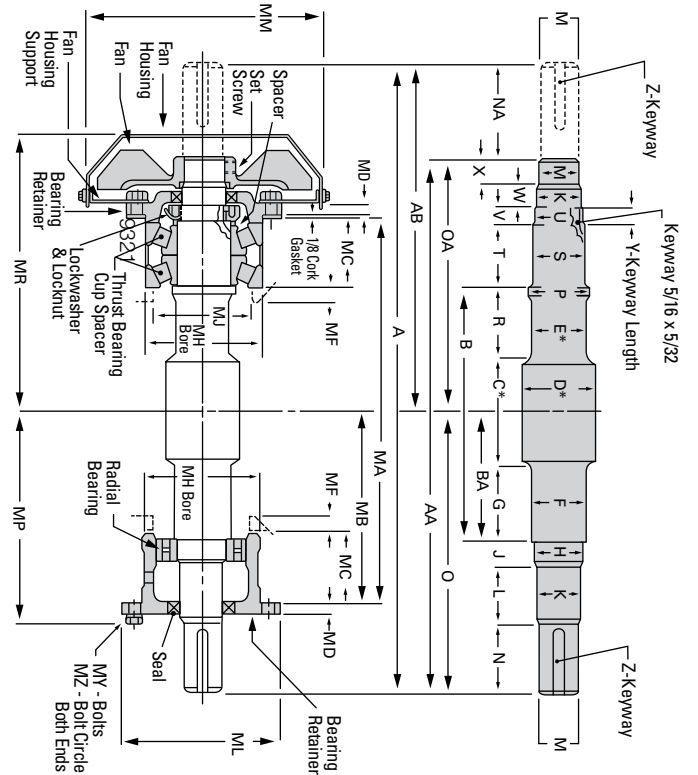

Center Distance	A	AA	AB	B	BA	C*	D*	E*	F	G	H	J	K	L	M	N	NA	O	OA	P	R	S	T	U	V	W	X	Y	Z-Keyway
8	23 1/2	15 1/2	11.260	5 3/4	6 3/16	3 5/16	2 3/4	2 15/32	2 5/8	2.1663	29/32	2.127	2 23/32	1.874	1.875	3 1/8	4 1/2	12 1/2	11	2 3/4	2 7/16	2.3765	2 13/16	2.360	3/4	15/16	1	25/32	1/2 x 1/4 x 3 1/16
9	32	27	17 3/4	12.385	6 5/16	5 31/32	3 11/16	-	2 23/32	3 9/32	2.3631	1	2.247	2.125	3 15/16	5	14 1/4	12 3/4	3	3 1/8	2.4390	3 1/4	2.360	1 1/8	NS-3	1 1/8	1 1/2	25/32	1/2 x 1/4 x 3 7/8
10	34 5/16	29 1/8	18 13/16	12.760	6 1/2	6 5/8	4 1/8	-	2 31/32	3 5/32	2.5600	1 1/8	2.502	2.250	4	5 3/16	15 1/2	13 5/8	3 1/8	2 31/32	2.7525	3 1/4	2.747	NS-3	7/8	1 3/4	1 1/2	15/16	1/2 x 1/4 x 3 15/16
12	39 9/16	33 3/8	21 9/16	15.198	7 11/16	6 7/8	4 3/4	-	3 3/32	4 3/16	2.7571	1 5/32	2.752	2.500	4 9/16	6 3/16	18	15 3/8	3 5/8	4 1/8	3.0025	3 3/4	2.933	NS-3	15/16	1 11/16	1 1/2	1 1/16	5/8 x 5/16 x 4 1/2
Center Distance	MA	MB	MC	MD	ME	MF	MH	MJ	ML	MM	MP	MRR	MY	MZ	Thrust Bearing	Spacer	Radial Bearing	Seal	Width										
8	17	8 1/2	3.125	3.127	1/2	1/2	5.1260	45/8	7 1/16	10 1/4	9 1/2	11 3/4	4 - 1/2	6	HM911245	HM911210EA	22211C	DH37J-1	3/8										
9	19	9 1/2	3.500	3.502	1/2	5/8	5.7510	5	7 13/16	12 1/4	10 1/2	13 13/16	6 - 1/2	6 3/4	H913842	H913810EA	22212C	DH37K-1	3/8										
10	21 1/4	10 5/8	4.437	4.439	5/8	5/8	5.7510	5	8	12 1/4	11 13/16	14 7/8	6 - 5/8	6 7/8	H913849	H913810EA	22213C	DH37L-1	1/2										
12	24 3/4	12 3/8	5.000	5.002	5/8	3/4	6.7510	6	9 5/16	12 1/4	13 9/16	16 5/8	6 - 5/8	8	9380	Y1S9321	22214C	DH37M-1	1/2										

\*Maximum varies with ratio

# Single and Double Extended Worm Assemblies without Fan

## 8" -12" Center Distance

Note: All dimensions and specifications are subject to change without notice. Work only from certified prints.

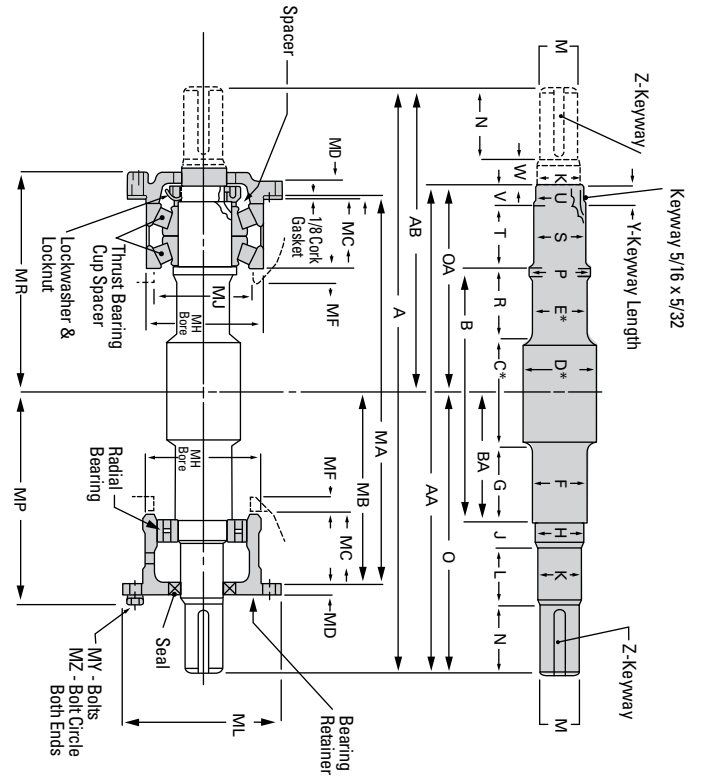

Center Distance	A	AA	AB	B	BA	C*	D*	E*	F	G	H	J	K	L	M	N	OA	P	R	S	T	U	V	W	X	Y	Z - Keyway	
8	25 5/8	21 9/16	13 1/8	11.260	5 3/4	6 3/16	3 5/16	2 3/4	2 15/32	2 5/8	2.1663	29/32	2.127	223/32	1.875	3 1/8	12 1/2	9 1/16	2 3/4	2.716	2.3765	2.13/16	2.360	3/4	15/16	1	25/32	1/2 x 1/4 x 3 1/16
9	29 7/16	24 3/8	15 3/16	12.385	6 5/16	5 31/32	3 11/16	-	2 23/32	3 9/32	2.3631	1	2.252	3	2.125	3 15/16	14 1/4	10 1/8	3	3 1/8	2.4390	3 1/4	2.360	13/16	1 1/8	1 1/2	25/32	1/2 x 1/4 x 3 7/8
10	31 1/8	25 7/8	15 5/8	12.760	6 1/2	6 5/8	4 1/8	-	2 31/32	3 5/32	2.5600	1 1/8	2.502	3 7/8	2.250	4	15 1/2	10 3/8	3 1/8	2.7525	3 1/4	2.747	7/8	1 3/4	1 1/2	15/16	1/2 x 1/4 x 3	
12	36 1/8	30 3/16	18 1/8	15.198	7 11/16	6 7/8	4 3/4	-	3 3/32	4 3/16	2.7571	1 5/32	2.752	4 19/32	2.500	4 9/16	18	12 3/16	3 5/8	3.0025	3 3/4	2.933	15/16	1 11/16	1 1/2	1 11/16	15/16	

5/8 x 5/16 x 4 1/2

Center Distance	MA	MB	MC	MD	ME	MH	MJ	ML	MP	MR	MY	MZ	Thrust Bearing	Spacer	Radial Bearing	Seal	Width
8	17	8 1/2	3.125	1/2	12	5.1260	4 5/8	7 1/16	9 1/2	9 3/4	4 - 1/2	6	HM911245	HM911210EA	22211C	DH37J-1	3/8
9	19	9 1/2	3.500	1/2	5/8	5.7510	5	7 13/16	10 1/2	11	6 - 1/2	6 3/4	H913842	H913810EA	22212C	DH37K-1	3/8
10	21 1/4	10 5/8	4.437	5/8	5/8	5.7510	5	8	11 13/16	12	6 - 5/8	6 7/8	H913849	H913810EA	22213C	DH37L-1	1/2
12	24 3/4	12 3/8	5.000	5/8	3/4	6.7510	6	9 5/16	13 9/16	13 11/16	6 - 5/8	8	9380	Y159321	22214C	DH37M-1	1/2

\*Maximum varies with ratio

# Single and Double Extended Worm Assemblies with Fan

## 14" -20" Center Distance

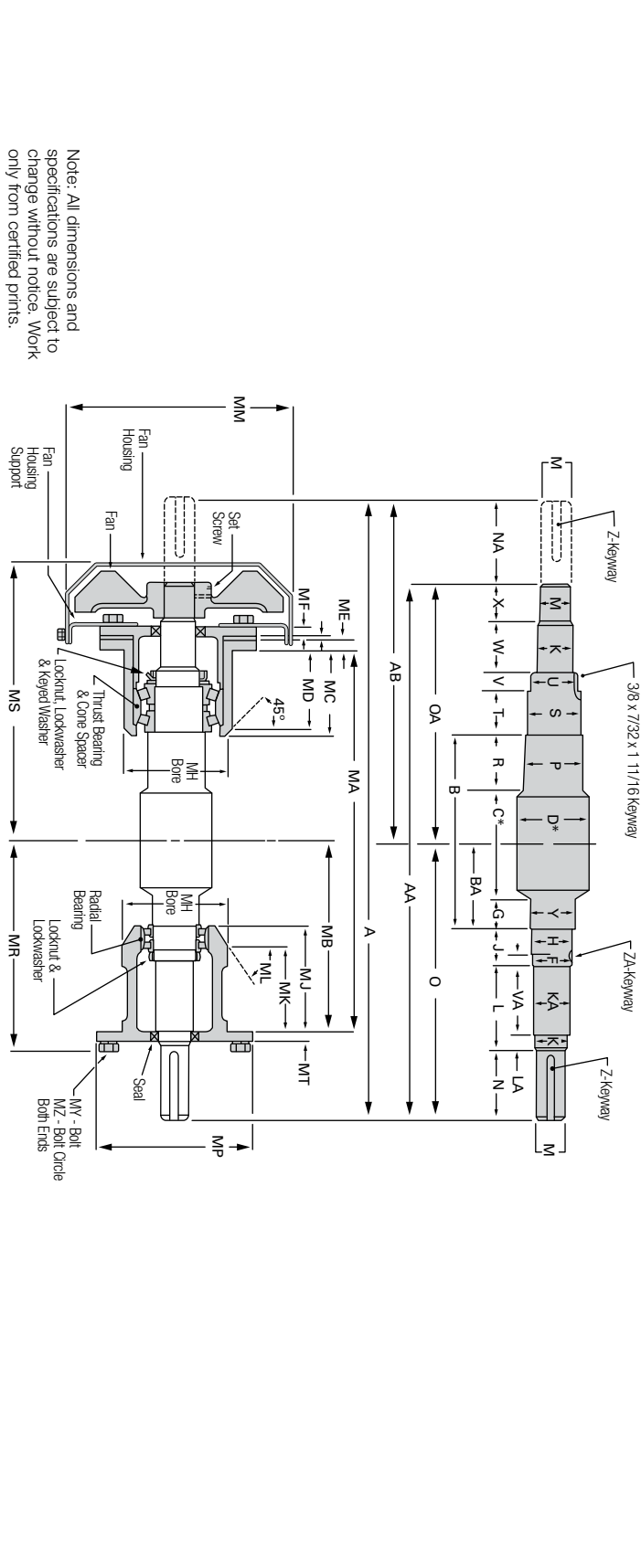

CENTER DISTANCE	A	MA	AB	B	BA	C	D	F	G	H	J	K	KA	L	LA	M	N	NA	O	OA	AA	A	MB	MJ	MK	MT	MR	MS	NA	X	W	V	T	R	C*	BA	LA	N	Y	H	F	KA	K	LA	M
14	47/32	39 1/8	26 3/8	16 1/4	8	7	5 3/16	3 1/37	4 1/2	3 25/32	3 9/16	-	3 0/5	1 15/16	-	3 0/0	7 1/2	8 1/4	21	18 1/8	4 13/16	4 3/4	3 8 1/4	4 1/8	3 7/30	1 1/2	1 5/16	-	4 1/4	3 15/16	3 4	3 38 x 5 5/8	3 8 x 3 16 x 1 9/16												
17	53	44 15/16	29	18	8	7 7/8	6 1/4	3 7/30	4	3 75/32	3 11/16	3 5/32	3 9/16	6 1/8	1 3/8	3 2/3	6 3/16	8 1/16	24	20 15/16	5 1/2	6 1/8	4 3/72	4 7/16	4 3/32	1 1/2	1 3/16	3 1/8	1 7/8	4 3/8	3 4 x 3 8 x 6 1/8	3 8 x 7/32 x 1 3/4													
20	60 3/8	51 1/16	33	20 3/16	8 3/4	11 1/4	7 3/16	3 7/30	2 15/16	3 75/32	3 11/16	-	3 9/16	5 11/16	-	3 5/0	9 1/4	9 5/16	27 3/8	23 11/16	5 3/4	6	4 5/25	4 7/16	4 3/32	1 1/2	1 3/16	-	6 5/16	4 3/8	7 8 x 7 1/6 x 6 15/16	3 8 x 7/32 x 1 3/4													

CENTER DISTANCE	MA	MB	MC	MD	ME	MF	MH	MJ	MK	ML	MM	MP	MR	MS	MT	MY	MZ	THRUST BEARING	SPACER	RADIAL BEARING	SPACER	SEAL	WIDTH
14	28	14	6	5 1/4	3/4	3/4	9 0/0	5 7/8	4 7/8	4 5/8	15 3/8	12 1/8	15 3/16	20 11/16	1 1/2	8 3/4	10 - 1/2	90381	X6SS0381	495	X1S495	DH37N-1	3/8
17	33 1/4	16 5/8	7 1/8	6 1/2	3/4	3/4	10 25/32	8 5/8	6 3/8	5 5/8	16 3/8	13 3/4	18 3/16	22 3/4	3/4	8 7/8	12	H9240U5	H9240SXA	42376	X1S42375	DH37E-6	1/2
20	37	18 1/2	7 3/8	7	7/8	7/8	10 75/32	9 3/4	7 1/16	5 5/8	20 1/2	14 3/4	20 3/16	28	3/4	8 - 1	12 - 3/4	HM926740	HM926740XA	42376	X1S42375	DH37E-6	1/2

\*Maximum varies with ratio

# Single and Double Extended Worm Assemblies without Fan

14" -20" Center Distance

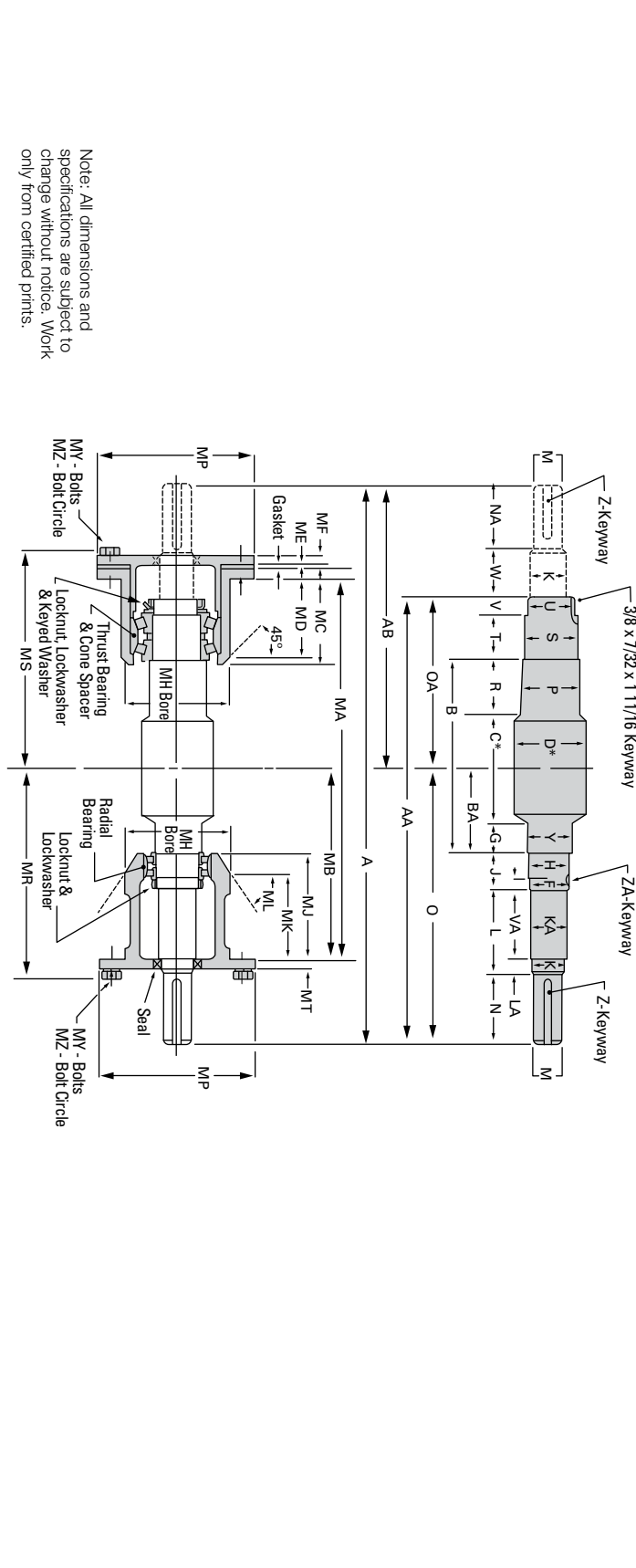

Center Distance	A	AA	AB	B	BA	C	D	F	G	H	J	K	KA	L	LA	M	N	NA	O	OA	P	R	S	T	U	V	WA	W	X	Y	Z	ZA	
14	43	34 7/8	22	16 1/4	8	7	5 3/6	3 137 12NS-3	4 1/2	3 255 3 255	3 9/16	-	3 015 3 005	1 5/16	-	3 000 2 999	7 1/2	8 1/4	21	18 1/6	4 13/16	4 3/4	3 814	4 1/8	3 730 12NS-3	1 1/2	1 5/16	-	4 1/4	3 15/16	34 x 38 x 5 5/8	38 x 36 x 1 9/16	
17	48 1/4	39 15/16	24 1/4	18	8	7 7/8	6 1/4	3 730 12NS-3	4	3 255 3 255	3 11/16	3 5/3	3 9/16	6 1/8	1 3/8	3 250 3 249	6 3/16	8 1/16	24	20	15/16	5 1/2	6 1/8	4 37/65	4 7/16	4 325 12NS-3	1 1/2	1 3/16	3 1/8	1 7/8	4 3/8	34 x 38 x 6 1/8	38 x 7 32 x 1 3/4
20	55 3/4	44 3/4	28 3/8	20 3/16	8 3/4	11 1/4	7 3/16	3 730 12NS-3	2 15/16	3 255 3 255	3 11/16	-	3 9/16	5 11/16	-	3 500 3 499	9 1/4	9 5/16	27 3/8	23	5 3/4	6	4 5015	4 7/16	4 325 12NS-3	1 1/2	1 3/16	-	6 5/16	4 3/8	7 8 x 7 7/16 x 6 15/16	3 8 x 7 32 x 1 3/4	

Center Distance	MA	MB	MC	MD	ME	MF	MH	MJ	MK	ML	MP	MIR	MS	MT	MV	MZ	Thrust Bearing	Spacer	Radial Bearing	Spacer	Seal	Width
14	28	14	6	5 1/4	3/4	3/4	9 000 9 002	5 7/8	4 7/8	4 5	12 1/8	15 3/16	16 3/16	7/2	8 3/4	10 1/2	90381 90744	X45S0381 Y45S0774	495 493D	X1S495	DH37N-1	3/8
17	33 1/4	16 5/8	7 1/8	6 1/2	3/4	3/4	10 250 10 252	8 5/8	6 3/8	5 5	13 3/4	18 3/16	18 15/16	3/4	8 7/8	12	H924045 H924010D	H92405A	42376 42587D	X1S42375	DH37E-6	1/2
20	37	18 1/2	7 3/8	7	7/8	7/8	10 750 10 752	9 3/4	7 1/16	5 5	14 3/4	20 3/16	21 3/16	3/4	8-1	12 3/4	HM926740 HM926710D	HM926740A	42376 42587D	X1S42375	DH37E-6	1/2





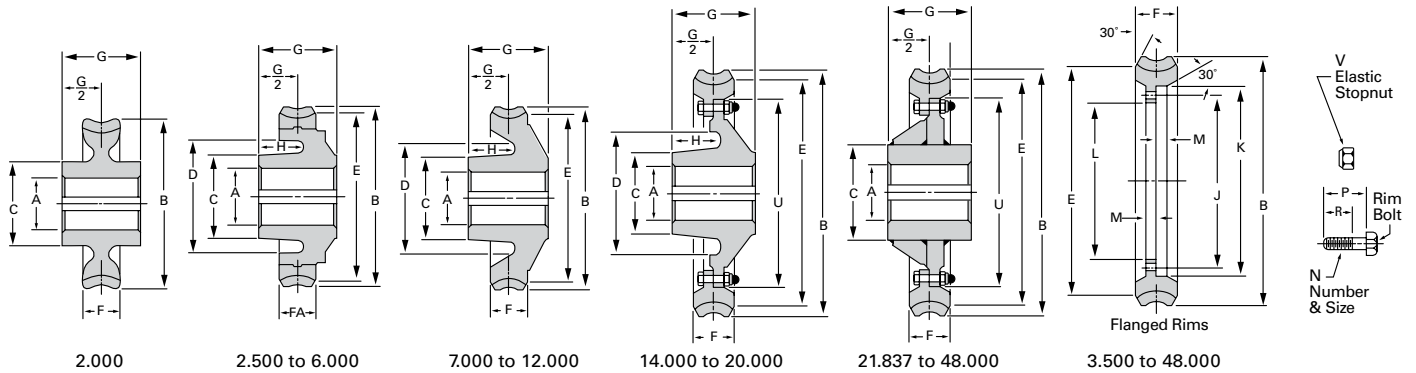

Center Distance	Delroyd Letter	A	B	C	D	E	F	FA	G	H	J	K	L	M	N	P	R	U	Keyway	V	Rimbolt
2	A	.998 999	3 3/8	1 1/2	-	-	5/8	-	.2004 1.996	-	-	-	-	-	-	-	-	-	1/4 x 1/8	-	-
2 1/2	B	1.375 1.376	4 3/8	2 1/4	-	4	7/8	7/8	1.879 1.871	-	-	-	-	-	-	-	-	-	5/16 x 5/32	-	-
3	C	1.500 1.501	5 1/4	2 3/8	3 3/8	4 5/8	1	15/16	2.379 2.371	1 3/8	-	-	-	-	-	-	-	-	3/8 x 3/16	-	-
3 1/2	D	1.625 1.626	6 3/16	2 5/8	3 5/8	5 1/2	1 1/4	1 1/16	2.442 2.434	1 13/32	3 5/8	4.3750 4.3764	2 7/8	7/16	4-3/8	-	-	4.3789 4.3780	3/8 x 3/16	-	-
4	E	1.875 1.876	7 1/8	3 1/8	4 1/2	6 7/16	1 1/2	1 1/8	2.504 2.496	1 5/8	4 1/2	5.2500 5.2516	3 3/4	1/2	4-3/8	1 5/8	3/4	5.2545 5.2535	12 x 1/4	29NE-066	DH53G
5	F	2.125 2.126	8 7/8	3 3/4	5 3/4	8 1/8	1 5/8	1 3/8	3.004 2.996	1 13/16	6	6.7500 6.7516	5 1/4	1/2	4-3/8	1 5/8	3/4	6.7555 6.7545	1/2 x 1/4	29NE-066	DH53G
6	G	2.5000 2.5012	10 11/16	4 1/2	7 1/8	10	1 3/4	1 1/2	3.504 3.496	2 3/16	7 3/4	8.5000 8.5018	7	1/2	6-3/8	1 5/8	3/4	8.5062 8.5050	5/8 x 5/16	29NE-066	DH53G
7	H	2.8750 2.8762	12 1/2	5	7 3/8	11 3/8	1 7/8	-	4.004 3.996	2 7/16	9 3/8	10.1250 10.1270	8 5/8	5/8	8-3/8	2 3/4	1 13/16	10.1322 10.1310	3/4 x 3/8	29NE-066	DH53H-20
8	J	3.1250 3.1262	14 3/8	5 1/2	8 7/8	13 1/8	2	-	4.504 4.496	2 11/16	10 5/8	11.6250 11.6270	9 5/8	5/8	6-1/2	2	1	11.6332 11.6320	3/4 x 3/8	29NE-083	DH53J
9	K	3.6250 3.6264	16 1/8	6 1/4	9 7/8	15	2 1/4	-	5.004 4.996	3 1/16	12 1/8	13.1250 13.1272	11 1/8	3/4	6-1/2	2 1/4	1	13.1344 13.1330	7/8 x 7/16	29NE-083	DH53K
10	L	3.8750 3.8764	17 7/8	6 5/8	10 9/16	16 1/2	2 1/2	-	5.504 5.496	3 3/8	13 5/8	14.6250 14.6272	12 5/8	3/4	8-1/2	2 1/4	1	14.6344 14.6330	1 x 1/2	29NE-083	DH53K
12	M	4.8750 4.8766	21 5/8	8 1/8	12 3/8	20	3	-	6.004 5.996	3 3/4	16 3/4	17.7500 17.7525	15 3/4	7/8	20-1/2	3	1 3/8	17.7616 17.7600	1 1/4 x 5/8	29NE-083	DH53J-20
14	N	5.3750 5.3766	25 1/4	9	13 1/2	23 1/2	3 1/4	-	6.004 5.996	3 1/2	19 1/4	21.000 21.003	17 1/2	1	10-5/8	3	1 1/8	21.014 21.012	1 1/4 x 5/8	29NE-101	DH53N
17	P	6.1250 6.1266	30 1/2	10 1/2	17	28 3/4	3 3/4	-	7.004 6.996	4 1/4	23 1/2	25.250 25.253	21 3/4	1 1/8	14-5/8	3 3/4	1 5/8	25.266 25.264	1 1/2 x 1/2	29NE-101	DH53P-20
18	SP	7.2500 7.2518	32	11	-	30	4	-	8.504 8.496	-	24	26.000 26.003	22	1 1/4	14-3/4	4 3/8	2	26.016 26.014	1 3/4 x 5/8	49NE-120	DH53R-20
20	R	7.1250 7.1268	36	11	21	34 1/4	4	-	8.004 7.996	4 3/4	28	30.000 30.003	26	1 1/4	14-3/4	4 3/8	2	30.016 30.014	1 3/4 x 5/8	49NE-120	DH53R-20
21.837	SR	7.2500 7.2518	39 1/4	11	-	37 1/2	5	-	9.504 9.496	-	29 3/4	32.000 32.004	27 1/2	1 1/2	14-1	4 1/8	1 3/8	32.0205 32.0180	1 3/4 x 5/8	49NE-168	DH53R
24	T	9.0000 9.0018	42	14	-	39 3/4	5 1/2	-	9.504 9.496	-	33 1/4	35.500 35.504	31	1 3/4	18-1	5 1/8	1 3/4	35.522 35.520	2 1/2 x 7/8	49NE-168	DH53U-20
27	ST	9.0000 9.0018	48	14	-	45 1/2	5 3/4	-	9.504 9.496	-	38 1/4	40.500 40.504	36	1 3/4	20-1	5 1/8	1 3/4	40.5225 40.5200	2 1/2 x 7/8	49NE-168	DH53U-20
28	ST	10.250 10.252	50	15	-	47 3/4	5 3/4	-	9.504 9.496	-	40 1/4	42.500 42.505	38	1 3/4	20-1	5 1/8	1 3/4	42.525 42.522	2 1/2 x 7/8	49NE-168	DH53U-20
30	U	10.2500 10.2520	54	15	-	51 3/4	6	-	11.504 11.496	-	44 1/4	46.500 46.505	42	2	20-1	5 1/8	1 3/4	46.525 46.522	2 1/2 x 7/8	49NE-168	DH53U-20
36	V	10.875 10.877	64 3/4	16	-	61 3/4	6 1/2	-	11.504 11.496	-	54 3/4	57.000 57.006	52 1/2	2	24-1	5 1/8	1 3/4	57.034 57.030	2 1/2 x 7/8	49NE-168	DH53U-20
42	SV	13.1875 13.1897	75 3/4	22	-	72 1/2	7	-	11.504 11.496	-	64	67.000 67.006	61	2 1/4	20-1 1/8	5 7/8	1 1/2	67.039 67.035	3 1/2 x 1 3/4	49NE-1808	DH53Y
48	W	15.3125 15.3147	88	25	-	86	7 1/2	-	11.504 11.496	-	76 1/2	79.500 79.508	74	2 1/4	24-1 1/8	5 7/8	1 1/2	79.545 79.540	3 1/2 x 1 3/4	49NE-1808	DH53Y

Note: All dimensions and specifications are subject to change without notice. Work only from certified prints

U = Center O. D.

# Gear Shaft Assemblies

## 2" - 4" Center Distance

Note: All dimensions and specifications are subject to change without notice. Work only from certified prints.

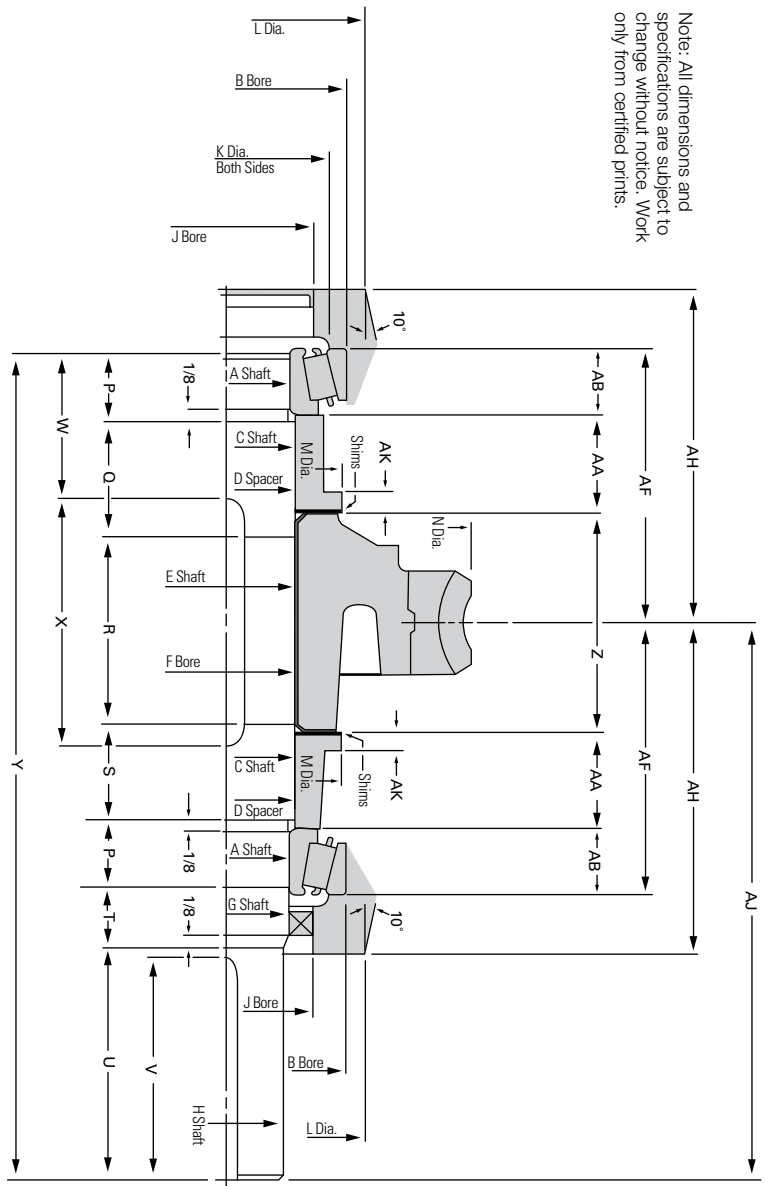

Center Distance	A	B	C	D	E	F	G	H	J	K	L	M	N	P	Q	R	S	T	U	V	W	X	Y	Z	AA	AB	AF	AH	AJ	AK	Gear Key	Part. C. Key
2	-	1.9820	-	-	-	.998	-	1.0005	.9985	1.438	11/16	2/12	-	3.38	-	-	-	-	1.78	9/16	2/8	5/8	2.000	-	.5690	1.596	2.065	4	-	1/4 SQ.	1/4 SQ.	
2 1/2	1.2515	2.3300	1.299	1.302	1.3774	1.375	1.2500	1.1250	1.687	2	2/8	2.2765	4.38	21/32	13/16	117/32	31/32	5/8	2/4	2.18	115/32	21/16	7/8	1.875	.6250	2.582	3.000	5.38	3/16	5/16 SQ.	1/4 SQ.	
3	1.3765	2.5945	1.426	1.429	1.5017	1.500	1.3750	1.2500	1.875	2 1/4	3/4	2.513	5 1/4	23/32	1 1/4	2 1/32	1 1/32	5/8	2/12	2.38	1 9/16	2.58	8/8	2.375	.9935	2.927	3.582	6	3/16	3/8 SQ.	3/8 SQ.	
3 1/2	1.5840	3.0020	1.612	1.615	1.6974	1.625	1.552	1.5000	2.375	2.58	3/4	2.982	6.3/16	1	1.38	2.3/32	1.5/32	13/16	3	2.15/16	2	2.58	107/16	2.438	1.1412	.9275	3.328	4.125	7/8	3/16	3/8 SQ.	3/8 SQ.
4	1.7975	3.2670	1.882	1.885	1.8774	1.875	1.781	1.750	2.824	2/8	3.3/4	3.217	7/8	1	2.5/32	2.5/32	1.15/16	7/8	3 1/2	37/16	2 11/16	2/8	12.9/8	2.500	1.9335	.9375	4.174	5.000	8 1/2	3/16	1/2 SQ.	3/8 SQ.

Center Distance	Timken Brgs. Part No.	Symbol	Seals	Width
2	L44630/L4610	DH37C-1		1/4
2 1/2	LM67049/LM67010	DH37B		1/4
3	LM485449/LM8510	DH37C		1/4
3 1/2	2789/2720	DH37D		5/16
4	25990/25520	DH37E		1/2

E-20 Shaft has 1.0005/.9995 Dia. for full length of Y.

# Gear Shaft Assemblies

## 5" - 12" Center Distance

Note: All dimensions and specifications are subject to change without notice. Work only from certified prints.

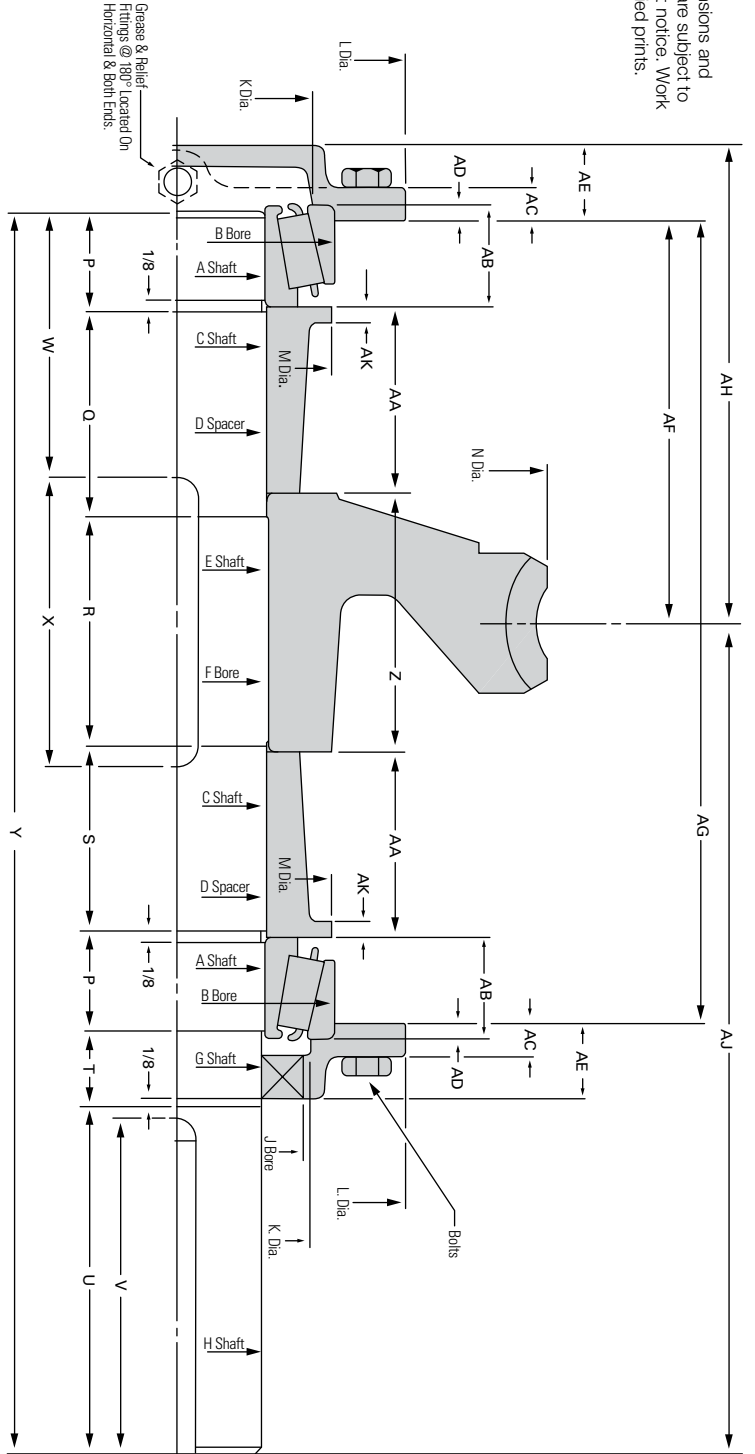

Center Distance	A	B	C	D	E	F	G	H	J	K	L	M	N	P	Q	R	S	T	U	V	W	X	Y	Z	AA	AB	AC	AD	AE	AF	AG	AH	AJ
5	20640	36718	2112	2115	2127	2125	2080	2000	30595	3178	5576	36238	8778	1582	238	22132	2532	778	4	3778	3176	338	1438	3000	21465	11875	38	1875	78	4825	9250	512	958
6	23765	44375	2487	2490	2527	2500	2375	2290	31235	3394	6176	43895	10778	1316	22932	3582	212	778	41/2	438	338	4	16178	3500	24535	11875	38	1875	1576	51875	10375	61/8	10374
7	26275	48125	2734	2739	2879	2870	2625	2500	36215	4174	61176	47645	12172	11582	2174	32132	2132	1176	5	41576	3178	458	161576	4000	20155	1500	12	125	1	5375	10750	63/8	1112
8	30025	53438	3104	3116	3129	3128	2875	2750	37465	4916	7916	5296	14398	12832	11576	4582	12332	1576	5/2	5776	3178	518	171316	4500	1704	1750	1/2	1875	1	5500	11000	61/2	1218
9	33925	63750	3698	3672	3627	3620	3500	3250	44985	5916	8916	6237	16178	12732	2776	42132	2732	1174	61/2	838	358	534	2034	5000	2204	1875	1/2	1875	11/4	6375	12750	75/8	14174
10	37525	67500	3859	3882	3878	3870	3750	3625	49975	5778	9376	6702	17778	12732	3	5582	22532	1776	71/4	7316	4178	638	23576	5500	2766	1875	5/8	1875	17/16	71875	14375	85/8	16
12	47525	81250	4859	4882	4875	4870	4375	4250	54985	7376	101176	8072	21578	12732	3576	52132	3332	1178	81/4	838	4576	778	2538	6000	3079	1875	5/8	1875	11/8	7750	15500	87/8	1712

Center Distance	AK	Qty.	Bolts Dia.	B.C	Gear Key	CPLg. Key	Timken Brgs. Part No.	Symbol	Seals Width
5	3/16	6	5/16	43/8	1/2 SQ.	1/2 SQ.	3767/3720	DH37F	1/2
6	3/16	6	3/8	51/8	5/8 SQ.	1/2 SQ.	3980/3920	DH37G	1/2
7	3/16	6	7/16	53/4	3/4 SQ.	5/8 SQ.	HH2120/9	DH37H	1/2
8	1/4	6	1/2	63/8	3/4 SQ.	5/8 SQ.	5760/5735	DH37J	1/2
9	1/4	6	1/2	73/8	7/8 SQ.	3/4 SQ.	7597/752	DH37K	5/8
10	1/4	6	9/16	77/8	1 SQ.	7/8 SQ.	77375/77615	DH37L	5/8
12	1/4	6	5/8	95/16	1 1/4 SQ.	1 SQ.	7957/92	DH37M	5/8

# Gear Shaft Assemblies

## 14"- 20" Center Distance

Note: All dimensions and specifications are subject to change without notice. Work only from certified prints.

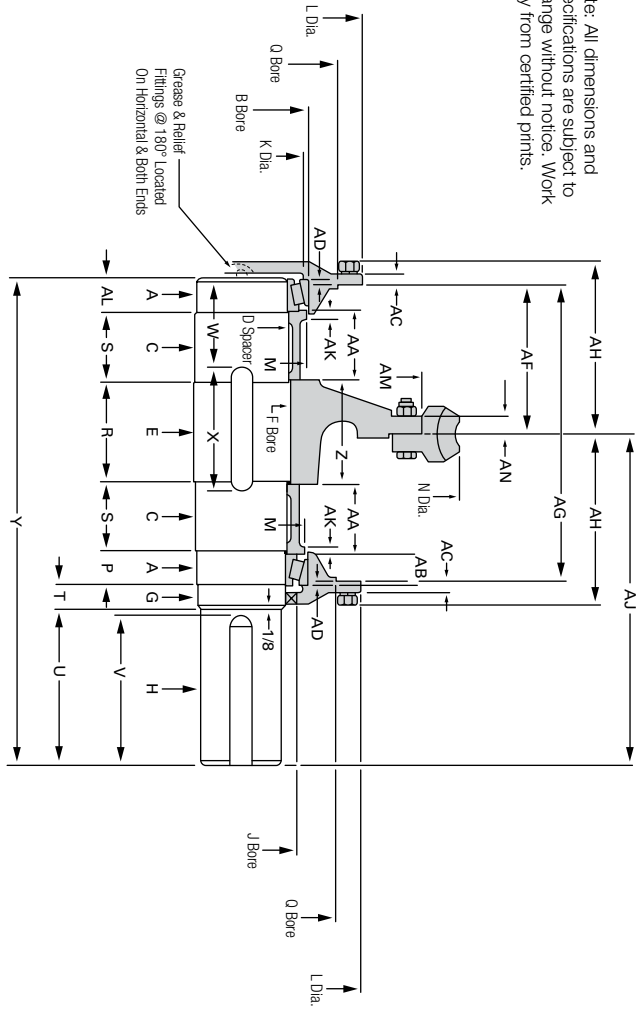

Center Distance	A	B	C	D	E	F	G	H	J	K	L	M	N	P	Q	R	S	T	U	V	W	X	Y	Z	AA	AB	AC	AD	AF	AG	AH	AJ	
14.000	5.2925	7.780	5.305	5.325	5.3785	5.3760	5.128	5.000	6.373	7.1/16	13.7/8	7.11/16	25.1/4	1.15/16	11.125	5.3/4	4.1/16	1.3/8	9	8.5/8	5.5/16	7.1/8	28.1/8	6.004	4.070	1.8205	5/8	.310	8.555	17.100	9.7/8	19.1/4	
	5.2515	7.752	5.295	5.335	5.3785	5.3766	5.125	4.999	6.375						11.127									5.996	4.050	1.8125		.300	8.545	17.090			
17.000	6.0025	10.000	6.070	6.080	6.1300	6.1250	5.878	5.750	7.125	8.15/16	16.1/2	9.15/16	30.1/2	2.3/4	13.251	6.3/4	4	1.3/8	10	9.3/4	6	8.1/4	31.5/8	7.004	4.010	2.633	13/16	.210	9.805	19.800	11.7/16	21.1/2	
	6.0015	10.002	6.060	6.090	6.1288	6.1266	5.875	5.749	7.127						13.253									6.996	4.000	2.625	.200	9.895	19.790				
20.000	7.0025	11.375	7.115	7.125	7.1312	7.1250	7.000	6.500	8.250	11.0.1/8	16.5/8	11.5/16	36	2.5/8	13.251	7.3/4	4.13/16	1.7/16	11	10.1/2	6.5/8	9.1/2	35.1/8	8.004	4.950	2.508	13/16	.275	11.150	22.290	12.11/16	23.3/4	
	7.0015	11.377	7.105	7.135	7.1300	7.1268	6.995	6.499	8.252						13.253									7.996	4.945	2.500	.285	11.140	22.280				

  

Center Distance	AK	Boles Qty.	Boles Dia.	B.C.	Gear Key	CHG. Key	Bearings	Seals Symbol	Seals Width	AL	AM	AN
14.000	1/2	8	5/8-11	12/12	1 1/4 X 1 1/4	1 1/4 SQ.	67390 67322	DH37N	5/8	1.15/16	21.014	1
											21.012	
17.000	1/2	8	3/4-10	15	1.2 X 1	1.1/2 SQ.	99600 99100	DH37P	5/8	2.3/4	25.264	1.1/8
											25.264	
20.000	1/2	8	3/4-10	15	1.3/4 X 1 1/4	1.1/2 SQ.	94700 94113	DH37SR-3	3/4	2.11/16	30.016	1.1/4
											30.014	

# Gear Shaft Assemblies

## 14"- 48" Center Distance

Note: All dimensions and specifications are subject to change without notice. Work only from certified prints.

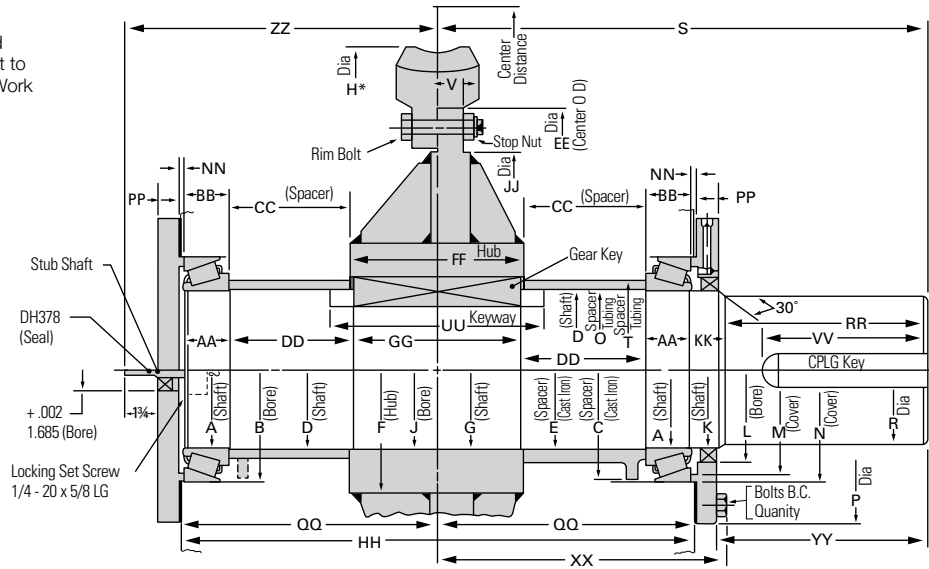

Center Distance	A	B	$-\frac{1}{32}$ C	D	E	F	G	H*	J	K	L	M	N	O	P	R	S	T	AA	BB	CC	DD	EE	FF	GG	HH	JJ	KK
14	5.2525 5.2515	7.750 7.752	7 11/16	5.305 5.295	5.315 5.325	8 1/2	5.3795 5.3783	25 1/4	5.3750 5.3766	5.128 5.125	6.373 6.377	7 1/8	7.748 7.746	5 3/8	10 3/4	5.000 4.999	23 1/4	6	1 15/16	1.8125 1.8205	6.834 6.830	6 13/16	21.0120 21.0140	6.004 5.996	5 3/4	23.760 23.740	17 1/4	1 3/8
17	6.0025 6.0015	10.000 10.002	9 15/16	6.070 6.060	6.080 6.090	9	6.1300 6.1288	30 1/2	6.1250 6.1266	5.878 5.875	7.123 7.127	8 7/8	9.998 9.996	6 1/4	13	5.750 5.749	25 1/2	7 1/4	2 3/4	2.625 2.633	6.521 6.517	6 9/16	25.2640 25.2660	7.004 6.996	6 3/4	25.760 25.740	21 1/2	1 3/4
20	7.0025 7.0015	11.375 11.377	11 5/16	7.115 7.105	7.125 7.135	11	7.1312 7.1300	36	7.1250 7.1268	7.000 6.997	8.248 8.252	10 1/4	11.373 11.371	7 1/4	14 1/2	6.500 6.499	26 1/2	8 1/4	2 5/8	2.500 2.508	7.458 7.454	7 7/16	30.0140 30.0160	8.004 7.996	7 3/4	28.510 28.490	25 3/4	1 9/16
21.837	7.0025 7.0015	11.375 11.377	11 5/16	7.140 7.130	7.150 7.160	11	7.2562 7.2550	39 1/4	7.2500 7.2518	7.000 6.997	8.248 8.252	10 1/4	11.373 11.371	7 1/4	14 1/2	7.000 6.999	25 1/4	8 1/4	2 5/8	2.500 2.508	6.333 6.329	6 5/16	32.0180 32.0205	9.504 9.496	9 1/4	27.760 27.740	27 1/4	1 7/16
24	8.6900 8.6890	12.376 12.378	12 5/16	8.915 8.905	8.925 8.935	14	9.0072 9.0060	42	9.0000 9.0018	8.628 8.625	10.621 10.627	11 9/16	13.373 13.371	9	15 1/2	8.4375 8.4365	27	9 3/4	2 9/16	2.4375 2.4455	6.834 6.830	6 7/8	35.5200 35.5225	9.504 9.496	9 1/4	28.510 28.490	30 3/4	1 9/16
27	8.6900 8.6890	12.376 12.378	12 5/16	8.915 8.905	8.925 8.935	14	9.0072 9.0060	48	9.0000 9.0018	8.628 8.625	10.621 10.627	11 9/16	13.373 13.371	9	15 1/2	8.4375 8.4365	28	9 3/4	2 9/16	2.4375 2.4455	7.709 7.705	7 3/4	40.5220 40.5250	9.504 9.496	9 1/4	30.260 30.240	35 3/4	1 9/16
28	10.0025 10.0015	14.1260 14.1282	14 1/16	10.170 10.160	10.180 10.190	15	10.2572 10.2560	50	10.2500 10.252	10.000 9.997	11.996 12.002	13 3/16	14.123 14.121	10 1/4	17 1/4	9.750 9.749	30	11	2 15/16	2.8125 2.8205	7.784 7.780	7 3/4	42.5220 42.5250	9.504 9.496	9 1/4	31.260 31.240	37 3/4	1 13/16
30	10.0025 10.0015	14.1260 14.1282	14 1/16	10.170 10.160	10.180 10.190	15	10.2572 10.2560	54	10.2500 10.252	10.000 9.997	11.996 12.002	13 3/16	14.123 14.121	10 1/4	17 1/4	9.937 9.936	30	11	2 15/16	2.8125 2.8205	7.784 7.780	7 3/4	46.5220 46.5250	11.504 11.496	11 1/4	33.260 33.240	41 3/4	1 11/16
36	10.6275 10.6265	15.0010 15.0032	14 15/16	10.640 10.630	10.650 10.660	16	10.8822 10.8810	64 3/4	10.875 10.877	10.378 10.375	11.621 11.627	14	14.998 14.996	10 3/4	18	9.937 9.936	30	11 3/4	3 1/16	2.9375 2.9455	7.609 7.605	7 5/8	57.0300 57.0340	11.504 11.496	11 1/4	33.260 33.240	52 1/4	1 15/16
42	13.1300 13.1290	18.5010 18.5035	18 7/16	13.140 13.130	13.150 13.160	22	13.1969 13.1955	75 3/4	13.1875 13.1897	13.003 13.000	14.496 14.502	17 1/4	18.498 18.496	13 1/4	23 1/2	12.875 12.874	39	14 1/2	3 3/4	2.5625 2.5705	10.334 10.330	10 1/4	67.0390 67.0440	11.504 11.496	11 1/4	40.010 39.990	60 3/4	2 1/8
48	15.2510 15.2500	21.5010 21.5040	21 7/16	15.265 15.255	15.275 15.285	25	15.3219 15.3205	88	15.3125 15.3147	13.503 13.500	15.496 15.502	20	21.497 21.495	15 3/8	26 1/2	13.250 13.249	40	17	3 9/16	3.4375 3.4455	11.454 11.450	11 7/16	79.5400 79.5450	11.504 11.496	11 1/4	42.010 41.990	73 3/4	2 1/8

\*Maximum varies with ratio. FS 420 & FS 480 have 2-Gear Keys (3 1/2 SQ) @ 90°

Center Distance	NN	PP	QQ	RR	UU	V	Timken BRG Part No.	C/R Seals Part No.	Max Width	Gear	Keys CPLG.	Qty.	Bolts Dia.	B.C.	VV	XX	YY	Stub Shaft Symbol	ZZ	Rim Bolts Qty.	Rim Bolts Symbol	Elastic Stop Nut
14	.250 .260	7/8	11.880 11.870	10 1/4	7	1	67390 67322	51251	5/8	1 1/4 x 1 1/4	1 1/4 x 1 1/4	8	5/8-11	9 1/4	9 7/8	13 1/8	10 1/2	DH1222N	14 1/2	10	DH53N	29NE-101
17	.250 .260	1	12.880 12.870	11 1/16	8 1/4	1 1/8	99600 99100	58716	5/8	1 1/2 x 1	1 1/2 x 1 1/2	8	5/8-11	11 1/2	11	14 1/4	11 5/8	DH1222P	15 5/8	14	DH53P-20	29NE-101
20	.313 .323	1	14.255 14.245	11	9 1/2	1 1/4	94700 94113	70032	3/4	1 3/4 x 1 1/4	1 1/2 x 1 1/2	8	3/4-10	13	10 1/2	15 3/4	11 1/4	DH1222P	17	14	DH53R-20	49NE-120
21.837	.313 .323	1	13.880 13.870	10 1/4	11	1 1/2	94700 94113	70032	3/4	1 3/4 x 1 1/4	1 1/2 x 1 1/2	8	3/4-10	13	9 1/8	15 3/8	10 3/8	DH1222SP	16 5/8	14	DH53SR-20	49NE-168
24	.250 .260	1 1/8	14.255 14.245	11 3/8	11 3/4	1 3/4	M244249 M244210	86260	1	2 1/2 x 1 3/4	2 x 2	12	3/4-10	14	10 1/2	15 7/8	11 5/8	DH1222SP	17 1/8	18	DH53U-20	49NE-168
27	.250 .260	1 1/8	15.130 15.120	11 1/2	11 3/4	1 3/4	M244249 M244210	86260	1	2 1/2 x 1 3/4	2 x 2	12	3/4-10	14	10	16 3/4	11 3/4	DH1222SP	18	20	DH53U-20	49NE-168
28	.300 .310	1 1/8	15.630 15.620	12 7/8	11 3/4	1 3/4	M249749 M249710	100051	1	2 1/2 x 1 3/4	2 3/8 x 2 3/8	12	3/4-10	15 3/4	10	17 1/4	13 1/4	DH1222ST-2	18 1/2	20	DH53U-20	49NE-168
30	.300 .310	1 1/8	16.630 16.620	12	11 3/4	2	M249749 M249710	100051	1	2 1/2 x 1 3/4	2 3/8 x 2 3/8	12	3/4-10	15 3/4	11	18 1/4	12 1/4	DH1222ST-2	19 1/2	20	DH53U-20	49NE-168
36	.350 .360	1 1/8	16.630 16.620	11 3/4	13 3/4	2	M252349 M252310	103740	7/8	2 1/2 x 1 3/4	2 3/8 x 2 3/8	12	3/4-10	16 1/2	10	18 1/4	12 1/4	DH1222ST-2	19 1/2	24	DH53U-20	49NE-168
42	.375 .385	1 1/4	20.005 19.995	17 1/4	13 3/4	2 1/4	HM261049 HM261010	GARLOCK 64X4093	11/16	3 1/2 x 3 1/2	3 x 3	12	1 1/4-7	21	16 1/2	22 3/8	17 3/4	-	23	20	DH53Y	49NE-1808
48	.375 .385	1 1/4	21.005 20.995	17 1/4	14 3/4	2 1/4	M667935 M667910	GARLOCK 64X4128	13/16	3 1/2 x 1 1/2	3 x 3	12	1 1/4-7	24	16 1/2	23 3/8	17 3/4	-	24	24	DH53Y	49NE-1808

# Shaft-Mounted Gear Shaft Assemblies

## 3" - 4" Center Distance

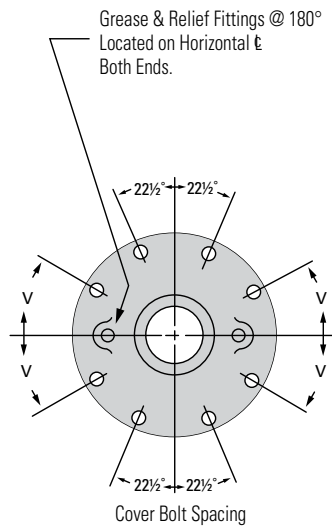

Note: All dimensions and specifications are subject to change without notice. Work only from certified prints.

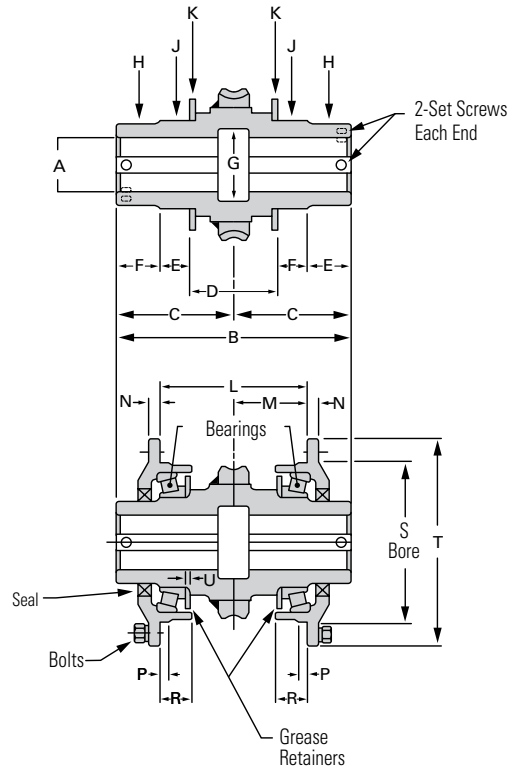

Center Distance	A	B	C	D	E	F	G	H	J	K	L	M	N	P	R	S	T	U	Gear O.D.	Keyway	V
3	1.9385 1.9405	8	4	3.273 3.255	15/16	1 7/16	2 1/2	2.876 2.872	3.0650 3.0640	4.738 4.733	5.000 4.990	2.505 2.495	5/16	1/4	1 1/16	5.5000 5.5016	7	.1345 .1295	5 1/4	1/2 X 1/4	30°
3 1/2	2.1885 2.1905	9 3/8	4 11/16	4.023 4.005	1	1 11/16	2 3/4	3.126 3.122	3.2838 3.2828	4.887 4.882	6.000 5.990	3.005 2.995	3/8	1/4	1 3/16	6.5000 6.5016	8 1/4	.1345 .1295	6 3/16	1/2 X 1/4	22 1/2°
4	2.438 2.440	10 5/8	5 5/16	3.773 3.755	1 7/16	2	3 1/8	3.501 3.497	3.7525 3.7515	5.957 5.952	7.000 6.990	3.505 3.495	3/8	1/4	1 3/4	7.3750 7.3768	9 1/8	.1345 .1295	7 1/8	5/8 X 5/16	22 1/2°

Center Distance	Qty.	Bolts Dia.	B.C.	Bearings	Seals Symbol	Seals Width
3	8	1/4-20	6 1/4	34306 34478	DH37J	1/2
3 1/2	8	5/16-18	7 3/8	27690 27620	DH37D-6	3/8
4	8	5/16-18	8 1/4	594 5924A	DH37E-6	3/8

# Shaft-Mounted Gear Shaft Assemblies

## 5"- 7" Center Distance

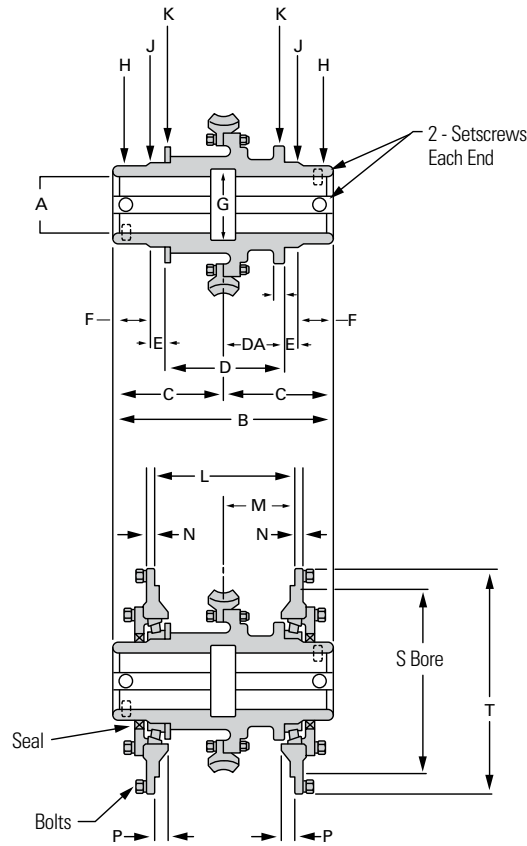

Note: All dimensions and specifications are subject to change without notice. Work only from certified prints.

Center Distance	A	B	C	D	DA	E	F	G	H	J	K	L	M	N	P	S	T	GEAR O. D.	Keyway
5	2.938	11 3/4	5 7/8	6.7635	3.377	7/8	1 5/8	3 7/8	4.188	4.2525	6.215	8.000	4.005	7/16	7/8	9.125	11 1/4	8 7/8	3/4 x 3/8
	2.940			6.7505	3.373				4.184	4.2515	6.200	7.990	3.995			9.127			
6	3.438	13	6 1/2	7.254	3.627	1	17 7/8	4 1/2	4.751	5.0025	7.090	8.500	4.255	7/16	7/8	11.250	13 1/2	10 7/8	7/8 x 7/16
	3.440			7.246	3.623				4.747	5.0015	7.075	8.490	4.245			11.252			
7	3.938	13 1/2	6 3/4	7.379	3.689	1 1/8	15 1/16	5 1/8	5.501	5.7525	7.590	9.000	4.505	1/2	1 1/16	12.750	14 7/8	12 1/2	1 x 1/2
	3.940			7.371	3.685				5.496	5.7515	7.575	8.990	4.495			12.752			

Center Distance	Qty.	Bolts Dia.	BC	Bearings	Seals Symbol	Seals Width
5	12	1/2-13	10 1/4	37425	DH37F-6	15/32
				37625		
6	12	1/2-13	12 1/2	L225849	DH37G-6	1/2
				L225818		
7	12	1/2-13	13 7/8	36690	DH37H-7	5/8
				36620		

# Shaft-Mounted Gear Shaft Assemblies

## 8" - 20" Center Distance

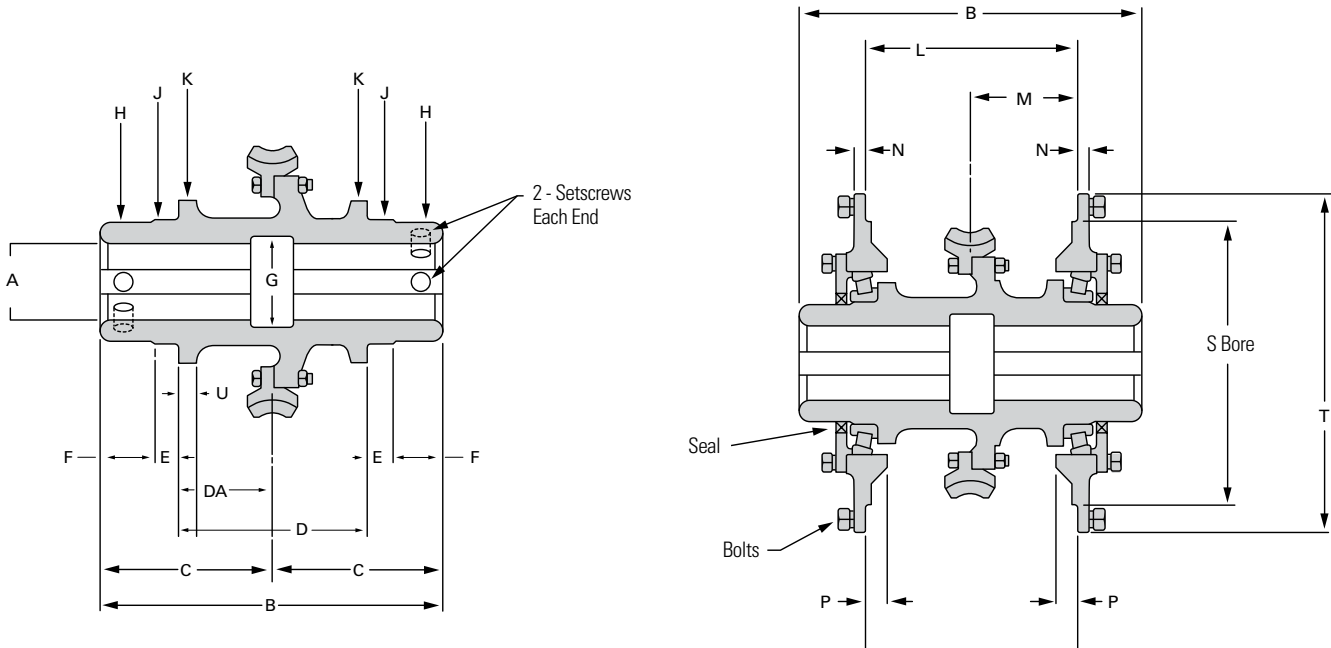

Note: All dimensions and specifications are subject to change without notice. Work only from certified prints.

Center Distance	A	B	C	D	DA	E	F	G	H	J	K	L	M	N	P	S	T	U	Gear O.D.	Keyway
8	4.438 4.440	14 1/2	7 1/4	7.504 7.496	3.752 3.748	1 1/2	2	5 1/2	6.255 6.245	6.5025 6.5015	8.840 8.820	9.250 9.240	4.630 4.620	5/8	1 1/8	14.500 14.502	16 7/8	3/8	14 3/8	1 x 1/2
9	4.938 4.940	16 1/2	8 1/4	9.004 8.996	4.502 4.498	1 3/4	2	6	7.003 6.995	7.0882 7.0872	9.800 9.780	11.250 11.240	5.630 5.620	11/16	1 3/8	16.250 16.252	18 3/4	3/8	16 1/8	1 1/4 x 7/16
10	5.438 5.440	18 1/2	9 1/4	10.754 10.746	5.377 5.373	1 9/16	2 5/16	6 1/2	7.503 7.495	7.7525 7.7515	10.090 10.075	12.250 12.240	6.130 6.120	3/4	1	18.125 18.128	21 1/8	3/8	17 7/8	1 1/4 x 7/16
12	6.000 6.002	19 1/2	9 3/4	11.005 10.995	5.502 5.498	1 13/16	2 7/16	7 1/4	8.003 7.995	8.1275 8.1265	11.090 11.070	13.000 12.990	6.505 6.495	3/4	1 1/4	21.750 21.752	24 7/8	3/8	21 5/8	1 1/2 x 1/2
14	6.000 6.002	21 1/2	10 3/4	12.505 12.495	6.252 6.248	1 13/16	2 11/16	7 1/4	8.003 7.995	8.1275 8.1265	11.090 11.070	15.000 14.990	7.505 7.495	3/4	1 1/2	25.750 25.753	29 3/8	1/2	25 1/4	1 1/2 x 1/2
17	6.500 6.502	24 1/2	12 1/4	14.005 13.995	7.002 6.998	2 1/2	2 3/4	7 3/4	9.253 9.245	9.3462 9.3452	13.188 13.156	17.000 16.990	8.505 8.495	1	1 3/4	31.000 31.003	34 7/8	5/8	30 1/2	1 1/2 x 1/2
20	6.500 6.502	27	13 1/2	16.505 16.495	8.252 8.248	2 1/2	2 3/4	7 3/4	9.253 9.245	9.3462 9.3452	13.188 13.156	19.000 18.990	9.505 9.495	1 1/4	2 1/4	36.500 36.503	40 11/16	5/8	36	1 1/2 x 1/2

Center Distance	Qty.	Bolts Dia.	B.C.	Bearings	Seals Symbol	Seals Width
8	12	5/8-11	15 3/4	46790 46720	DH37J-7	1/2
9	12	5/8-11	17 1/2	JM736149 JM36110	DH37K-7	1/2
10	12	5/8-11	19 3/4	LM739749 LM739710	DH37L-7	3/4
12	12	3/4-10	23 1/2	67985 67920	DH37P-12	3/4
14	12	3/4-10	27 3/4	67985 67920	DH37P-12	3/4
17	16	7/8-9	33	M246949 M246910	DH37P-7	5/8
20	16	1-8	38 3/4	M246949 M246910	DH37P-7	5/8



# Helical Attachment Assemblies

## 2 1/2" - 7" Center Distance

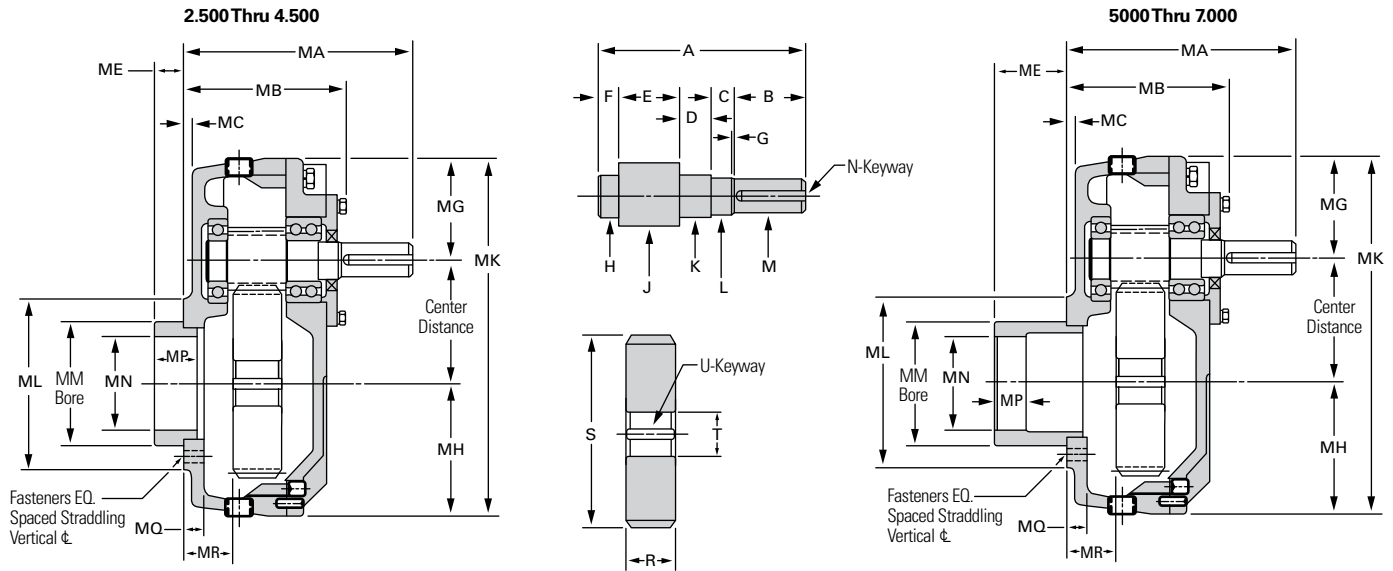

Note: All dimensions and specifications are subject to change without notice. Work only from certified prints.

Center Distance	A	B	C	D	E	F	G	H	J	K	L	M	N-Keyway	R	S	T	U-Keyway	Bearings			Width
																		Single	Double	Seal	
2 1/2	5 1/4	2	3/4	3/4	1.252 1.248	1/2	1/16	.7878 .7875	1.402	.7878 .7875	.783 .779	.7500 .7495	3/16 x 3/32 x 1 15/16	1.000 .995	4.232	.9995 1.0005	1/4 x 1/8	6204	5504	DH37D-10	3/8
3	5 5/16	2	3/4	3/4	1.283 1.279	17/32	3/32	.7878 .7875	1.671	.9847 .9844	.971 .967	.8750 .8745	3/16 x 3/32 x 1 15/16	1.000 .995	5.073	1.1245 1.1255	1/4 x 1/8	6304	5205	DH37E-10	3/8
3 1/2	6 1/16	2 1/4	13/16	7/8	1.564 1.560	9/16	1/16	1.1815 1.1812	1.921	1.1815 1.1812	1.158 1.154	1.1250 1.1245	1/4 x 1/8 x 2 3/16	1.250 1.245	5.907	1.3745 1.3755	5/16 x 5/32	6206	5206	DH37F-10	3/8
4	6 15/16	2 1/2	13/16	1	2.002 1.998	5/8	1/8	1.3785 1.3781	2.195	1.3785 1.3781	1.377 1.373	1.2500 1.2495	1/4 x 1/8 x 2 7/16	1.500 1.495	6.751	1.4995 1.5005	3/8 x 3/16	6207	5507	DH37G-10	3/8
4 1/2	7 15/16	2 3/4	7/8	1 5/16	2.252 2.248	3/4	-	1.3785 1.3781	2.445	1.3785 1.3781	1.3750 1.3745	1.3750 1.3745	5/16 x 5/32 x 2 11/16	1.750 1.745	7.584	1.6245 1.6255	3/8 x 3/16	6307	5607	DH37G-10	3/8
5	8 1/2	3	7/8	1 3/8	2.377 2.373	7/8	1/16	1.5753 1.5749	2.728	1.5753 1.5749	1.564 1.560	1.5000 1.4995	3/8 x 3/16 x 2 15/16	2.000 1.995	8.431	1.8745 1.8755	1/2 x 1/4	6308	5608	DH37J-10	3/8
5 1/2	9 9/16	3 1/2	7/8	1 1/2	2.752 2.748	15/16	-	1.7722 1.7718	2.977	1.7722 1.7718	1.750 1.749	1.750 1.749	3/8 x 3/16 x 3 7/16	2.250 2.245	9.265	2.1245 2.1255	1/2 x 1/4	6309	5609	DH37K-10	3/8
6	10 7/16	3 3/4	13/16	1 7/8	2.939 2.935	1 1/16	1/8	2.1660 2.1655	3.304	2.1660 2.1655	2.127 2.123	1.875 1.874	1/2 x 1/4 x 3 11/16	2.500 2.495	10.078	2.1245 2.1255	1/2 x 1/4	6311	5611	DH37L-10	7/16
7	12	4 1/4	1	2 1/16	3.502 3.498	1 3/16	1/16	2.3628 2.3623	3.842	2.3628 2.3623	2.190 2.186	2.125 2.124	1/2 x 1/4 x 4 3/16	3.000 2.995	11.814	2.4995 2.5005	5/8 x 5/16	6312	5612	DH37M-10	7/16

Center Distance	MA	MB	MC	ME	MG	MH	MK	ML	MM	MN	MP	MQ	MR	Qty.	Fasteners Size & Type		B.C.
2 1/2	5 7/8	3 15/16	1/8	1/4	2 3/4	3 1/8	8 3/8	4 5/8	2.532 2.534	1 7/8	-	7/16	1 1/4	4	5/16-18 x 1 Capscrew		3 3/4
3	6 1/16	4 1/8	3/16	3/8	2 7/8	3 1/2	9 3/8	5	2.876 2.878	2 1/4	-	1/2	1 13/32	4	5/16-18 x 1 Capscrew		4 1/8
3 1/2	6 13/16	4 5/8	1/4	1.070 1.065	3 1/2	4	11	5 3/4	4.3870 4.3884	3 1/2	-	5/8	1 7/16	4	5/16-18 x 1 3/4 Stud		5
4	7 13/16	5 3/8	5/16	1.325 1.320	3 5/8	4 3/4	12 3/8	6 3/4	4.8850 4.8866	3 3/4	-	3/4	1 23/32	4	7/16-14 x 2 1/4 Stud		5 3/4
4 1/2	8 13/16	6 1/8	5/16	1.757 1.752	4	5 1/8	13 5/8	6 3/4	4.8850 4.8866	3 3/4	-	3/4	1 27/32	4	7/16-14 x 2 1/4 Stud		5 3/4
5	9 1/2	6 5/8	3/8	3 1/16	4 3/8	5 1/2	14 7/8	7 1/8	5.1260 5.1276	3.9370 3.9384	1 3/8	1	2 3/32	4	1/2-13 x 2 3/4 Stud		6
5 1/2	10 5/8	7 1/4	7/16	3 7/16	4 7/16	6 3/16	16 1/8	7 7/8	5.7510 5.7526	4.3307 4.3321	1 1/2	1	27/32	6	1/2-13 x 2 3/4 Stud		6 3/4
6	11 5/8	8 3/16	7/16	4 3/8	5 1/4	6 1/2	17 3/4	8	5.7510 5.7526	4.7244 4.7258	1 1/2	1	2 19/32	6	5/8-11 x 3 1/8 Stud		6 7/8
7	13 1/4	9 1/4	1/2	4 15/16	5 11/16	7 5/16	20	9 3/8	6.7510 6.7526	4.9213 4.9229	1 5/8	1-1/16	2 23/32	6	5/8-11 x 3 1/8 Stud		8

# Primary Worm Attachment Assemblies

## 2"- 6" Center Distance

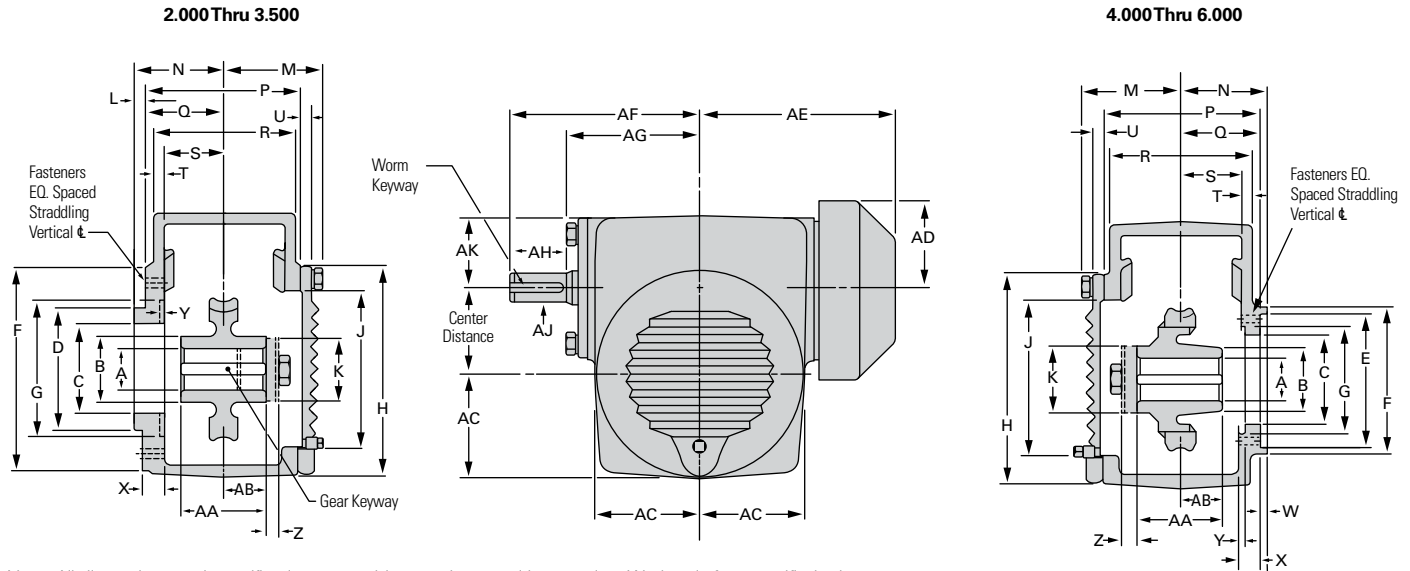

Note: All dimensions and specifications are subject to change without notice. Work only from certified prints.

Center Distance	A	B	C	D	E	F	G	H	J	K	L	M	N	P	Q	R	S	T	U	W	X	Y	Z	AA	AB	AC	AD	AE
2	1.000 1.001	1 1/2	2 1/8	2.5300 2.5294	-	4 7/8	-	5	3.875 3.880	1 1/2	1/4	25/16	2 1/8	3 11/16	1.873 1.868	3 3/8	1 7/16	1/4	1/4	-	7/16	-	5/16	2.004 1.996	1.002 .998	2 1/2	2 1/8	4 9/16
2	1.125 1.126	1 1/2	2 1/8	2.8738 2.8731	-	4 7/8	-	5	3.875 3.880	1 1/2	1/4	25/16	2 1/8	3 11/16	1.873 1.876	3 3/8	1 7/16	1/4	1/4	-	7/16	-	5/16	2.004 1.996	1.002 .998	2 1/2	2 1/8	4 9/16
2 1/2	1.375 1.376	2	2.625 2.626	3.0615 3.0605	-	5 3/4	3 3/8	6	4.750 4.755	1 3/4	245 250	2 3/8	25/16	3 15/16	2.070 2.060	3 3/8	1 7/16	1/4	1/4	-	5/8	1/16	5/16	1.879 1.871	.9395 .9355	3	2 1/8	5 1/16
3	1.500 1.501	2 3/8	3.375 3.376	3.811 3.810	-	6 3/4	4 1/8	7 1/4	5.937 5.942	2	245 250	2 13/16	2 13/16	4 7/8	2.572 2.562	4 1/2	2 1/8	1/4	1/4	-	1/2	1/16	5/16	2.379 2.371	1.1895 1.1855	3 5/8	2 5/8	5 15/16
3 1/2	1.625 1.626	2 5/8	3.750 3.751	4.3297 4.3287	-	6 3/4	4 1/2	8 1/4	6.812 6.817	2 1/4	245 250	2 15/16	3 1/16	5 1/4	2.822 2.812	4 3/4	2 3/16	5/16	1/4	-	5/8	1/16	5/16	2.442 2.434	1.221 1.217	4 1/8	2 5/8	6 5/8
4	1.875 1.876	3 1/8	4.312 4.313	-	6.875 6.877	7 1/2	5 1/8	8 7/8	7.625 7.630	2 1/2	-	3 1/8	2 13/16	5 1/4	2.635 2.625	4 7/8	2 1/8	5/16	1/4	3/16	7/16	1/16	5/16	2.504 2.496	1.252 1.248	4 7/16	3 5/16	8
5	2.125 2.126	3 3/4	4.750 4.751	-	7.625 7.627	8 1/2	5 5/8	11	9.437 9.442	2 3/4	-	3 9/16	35/16	6 3/16	3.135 3.125	5 3/4	2 1/2	3/8	1/4	3/16	9/16	1/16	5/16	3.004 2.996	1.502 1.498	5 1/2	3 11/16	8 5/8
5	2.125 2.126	3 3/4	4.750 4.751	-	7.750 7.752	8 1/2	5 5/8	11	9.437 9.442	2 3/4	-	3 9/16	35/16	6 3/16	3.135 3.125	5 3/4	2 1/2	3/8	1/4	3/16	9/16	1/16	5/16	3.004 2.996	1.502 1.498	5 1/2	3 11/16	8 5/8
6	2.5000 2.5012	4 1/2	5.250 5.251	-	9.125 9.127	9 3/4	6 1/4	13 1/4	11.375 11.380	3 1/4	-	4 5/16	3 5/8	6 15/16	3.385 3.375	6 3/4	2 13/16	3/8	3/8	1/4	9/16	1/16	3/8	3.504 3.496	1.752 1.748	6 5/8	4 1/8	10 1/16

Center Distance	AF	AG	AH	AJ	AK	QTY.	Fasteners Size & Type	B.C.	Gear Keyway	Worm Keyway	Seal	Width
2	4 1/2	3 3/16	1 5/16	.6875 .6870	1 11/16	4	5/16-18 x 1 Capscrew	3 3/4	1/4 x 1/8	3/16 x 3/32 x 1 7/32	DH37B-1	1/4
2	4 1/2	3 3/16	1 5/16	.6875 .6870	1 11/16	4	5/16-18 x 1 Capscrew	4 1/8	1/4 x 1/8	3/16 x 3/32 x 1 7/32	DH37B-1	1/4
2 1/2	5 3/8	3 11/16	1 3/4	.6875 .6870	1 13/16	4	5/16-18 x 1 3/4 Stud	5	5/16 x 5/32	3/16 x 3/32 x 1 11/16	DH37B-1	1/4
3	6 1/8	4 1/4	1 7/8	.8750 .8745	2 1/4	4	7/16-14 x 2 1/4 Stud	5 3/4	3/8 x 3/16	3/16 x 3/32 x 1 13/16	DH37C-1	1/4
3 1/2	7	5 1/16	2	1.0000 .9995	2 7/16	4	7/16-14 x 2 1/4 Stud	5 3/4	3/8 x 3/16	1/4 x 1/8 x 1 15/16	DH37D-1	1/4
4	7 3/4	5 3/4	2 1/16	1.1250 1.1245	2 3/4	4	1/2-13 x 2 3/4 Stud	6	1/2 x 1/4	1/4 x 1/8 x 2	DH37E-1	1/4
5	8 3/4	6 3/8	2 5/16	1.3750 1.3745	3 1/4	6	1/2-13 x 2 3/4 Stud	6 3/4	1/2 x 1/4	5/16 x 5/32 x 2 1/4	DH37F-1	5/16
5	8 3/4	6 3/8	2 5/16	1.3750 1.3745	3 1/4	6	5/8-11 x 3 1/8 Stud	6 7/8	1/2 x 1/4	5/16 x 5/32 x 2 1/4	DH37F-1	5/16
6	10 1/4	7 7/8	2 11/16	1.500 1.499	3 3/4	6	5/8-11 x 3 1/8 Stud	8	5/8 x 5/16	3/8 x 3/16 x 2 5/8	DH37G-1	5/16

# Recommendations and Precautions

## Important

Read before selecting, installing, operating or maintaining Delroyd reducers. **WARNING: SELECT, INSTALL, OPERATE AND MAINTAIN DELROYD EQUIPMENT ONLY IN ACCORDANCE WITH THE FOLLOWING INSTRUCTIONS, AND DELROYD CATALOGS AND INSTRUCTION BOOKS. FAILURE TO OBSERVE THIS WARNING COULD RESULT IN SEVERE BODILY INJURY AND PROPERTY DAMAGE. CONTACT DELROYD TO GET CATALOGS AND INSTRUCTION BOOKS** All catalog information, warning tags, these instructions, all special or general instruction manuals, parts lists, maintenance instructions, and drawings must be kept with the reducer.

## I. Safe Operation Depends on Selecting the Proper Reducer

### A. Selection Responsibility

1. Delroyd Customers are responsible for selecting proper reducers.
2. Delroyd customers must select reducers that can be used in accordance with Delroyd criteria concerning transmitted horsepower, speed, applied external loads, applied axial thrust loads and applicable service factors. Use of Delroyd reducers must conform to all such criteria.
3. Customers requesting recommendations from Delroyd concerning reducer selection must provide accurate and complete information concerning all operation variables that may be encountered in the proposed reducer application. Such variables include but are not limited to loads, speeds, shock, ambient temperature and published Delroyd service factors.

### B. Reducer Compatibility with the Drive System

1. When selecting a reducer, the customer must analyze the motor, reducer, driven machine and all connecting parts for compatibility, critical torsional or other vibrations and other applicable forces during all modes of operation.
2. The customer should request Delroyd assistance in selecting a reducer if conditions such as overloads during starting, momentary peak or stalling loads, high inertial starting or stopping systems, reversing direction of rotation, over-running operations, corrosive or dusty atmospheres or ambient temperatures under 20°F or over 100°F might be encountered.
3. When selecting a motor for a Delroyd reducer, NEMA (National Electrical Manufacturers Association) Standards Publication MG2 (Safety Standards for Construction and Guide for Selection, Installation and Use of Fractional and Integral Horsepower Motors and Generators) must be obtained and studied. Electrical and other motor hazards should be considered. In all instances the motor manufacturer's instructions should be followed carefully. Such instructions must be obtained from the motor manufacturer directly or through Delroyd.

## II. Installation of Delroyd Reducers

### A. Upon Receipt of Shipment

1. Examine the equipment for damage and corrosion. Report any discrepancy to the shipper, and to Delroyd for replacement or repair.
2. Examine the reducer nameplate and motor nameplate (if a motor is also supplied) to be sure the proper equipment has been received.
3. Do not remove these name plates. They are provided to identify the model number, size and serial number so that Delroyd can supply the proper spare or replacement parts to you or any subsequent owner. The information on name plates also enables the user to check manufacturer's publications for instructions concerning proper application, installation, operation and maintenance of reducers and motors.
4. Study and retain all warning tags, instruction, parts lists and parts drawings received with the shipment or sent separately.

### B. Installation

1. Follow Delroyd installation instructions and the instructions of the motor manufacturer.
2. Provide proper OSHA conforming safety guards for couplings, exposed rotating shafting, belts or chains on your Delroyd reducer installation.

3. Lifting eyebolts or other lifting devices supplied with the reducer are designed for raising the reducer only. They should not be used to lift the reducer plus other components, and should be removed after installing the reducer.
4. All Delroyd reducers are shipped without oil. Add oil to proper oil level before starting. Allow sufficient time for the oil to fill all parts of the reservoir and recheck the level.

## III. Operation of Delroyd Reducers

### A. Before First Starting the Reducer

1. Disconnect the reducer from its driving motor and check motor rotation. Reverse motor rotation if necessary and reconnect the reducer.
2. Rotate the motor and reducer by hand to be sure all components turn freely.
3. Replace all safety guards.
4. Review reducer operating instructions, lubrication schedules, and maintenance schedules.
5. Review Motor manufacturer's operating instructions.

### B. Fan Precautions

Most Delroyd reducers are equipped with a fan for cooling the reducer. This fan is guarded, but must have inlet and outlet air openings to provide the necessary air movement. To avoid severe bodily injury or property damage:

1. Do not remove the fan guard or insert fingers or other objects into the air openings when the reducer is operating.
2. Shut down and lock out the motor driving the reducer before the fan or fan guard is removed or in any way adjusted.

### C. Inspections

As with all mechanical equipment, a program of regular inspection is important to prolong equipment life and to safeguard people and property.

1. Periodic inspection of the reducer must be made every 2,000 hours of operation or every six (6) months, whichever such period expires earlier.
2. The above inspection must also be conducted after each time the reducer has been subjected to any overload, or stall condition or loss of lubricant.
3. Reducer parts that are damaged or worn, or the presence of contaminants (such as water, dirt, bronze or steel particles) in drainage oil could indicate impending failure. An increase in noise, a drastic increase in backlash, an increase in motor HP required, or other erratic behavior of the reducer could indicate impending failure.
4. If any of the above conditions are observed, the reducer should be immediately taken out of service until the cause of the condition is determined and corrections made. Consult Delroyd for assistance. Failure to immediately remove such a reducer from service could result in loss of control of the driven machine and consequent severe bodily injury or property damage.

## IV. Maintenance of Delroyd Reducers

- A. Care should be exercised when draining oil during lubricant replacement. Oil temperatures of 180°F to 200°F can normally be expected and severe burns could result if oil contacts personnel or their clothing.
- B. Before beginning removal or disassembly of any part of your Delroyd reducer for maintenance or inspection, lock out the driving motor control panel to prevent inadvertent starting and disconnect driven load.
- C. Repairs can be done by Delroyd using factory stocked or manufactured parts if the reducer can be returned to our plant in Niagara Falls, New York. If repairs are done elsewhere, all instruction book adjustments must be followed and Delroyd manufactured parts must be used.
- D. The motor manufacturer's instructions should be followed carefully in performing motor maintenance.



# Premier Industrial Company Leading Brands

## OTHER PRODUCT SOLUTIONS FROM **REGAL REXNORD**

Our comprehensive product offerings include various types of clutches and brakes, overrunning clutches, engineered bearing assemblies, gearing and gear motors along with linear motion products, belted drives, couplings, limit switches, precision motors, drives & controls, and miniature motors. With thousands of product solutions available, Regal Rexnord provides true single source convenience while meeting specific customer requirements. Many major OEMs and end users prefer Regal Rexnord products as their No. 1 choice for performance and reliability.

[WWW.REGALREXNORD.COM](http://WWW.REGALREXNORD.COM)



### **Electric Clutches & Brakes**

Stromag  
Warner Electric



### **Precision Motors & Automation**

Kollmorgen



### **Heavy Duty Clutches & Brakes**

Industrial Clutch  
Stromag  
Svendborg Brakes  
Twiflex  
Wichita Clutch



### **Miniature Motors**

Portescap



### **Overrunning Clutches**

Formsprag Clutch  
Marland Clutch  
Stieber



### **Linear Systems**

Thomson



### **Engineered Couplings & Universal Joints**

Ameridrives  
Bibby Turboflex  
Guardian Couplings  
Huco  
Lamiflex Couplings  
Stromag  
TB Wood's



### **Specialty Components**

Kilian  
Stromag  
TB Wood's



### **Gear Drives & Gear Motors**

Bauer Gear Motor  
Boston Gear  
Delroyd Worm Gear  
Nuttall Gear

## Delroyd Worm Gear Facilities

### North America

#### USA

2221 Niagara Falls Boulevard  
Niagara Falls, NY 14304 - USA  
716-298-4100

*Worm Gear and  
Helical Speed Reducers*



**Scan to see all  
the brands of  
Regal Rexnord**

Neither the accuracy nor completeness of the information contained in this publication is guaranteed by the company and may be subject to change in its sole discretion. The operating and performance characteristics of these products may vary depending on the application, installation, operating conditions and environmental factors. The company's terms and conditions of sale can be viewed at <http://www.altramotion.com/terms-and-conditions/sales-terms-and-conditions>. These terms and conditions apply to any person who may buy, acquire or use a product referred to herein, including any person who buys from a licensed distributor of these branded products.

©2023 by Delroyd Worm Gear LLC. All rights reserved. All trademarks in this publication are the sole and exclusive property of Delroyd Worm Gear LLC or one of its affiliated companies.

