

PULP AND PAPER

## L&W Tensile Tester

Testing and industry-specific instruments



L&W Tensile Tester measures all important tensile properties. It is sensitive enough to precisely measure on tissue and strong enough to measure on packaging board. The instrument is available with options for wet tensile testing as well as fracture toughness evaluation.

L&W Tensile Tester is the fourth generation of L&W product's horizontal tensile tester since 1975. Horizontal measurements have proven to be a more reliable and easier method to determine the strength properties of paper than vertical measurements. In a single measurement four basic properties are calculated: tensile strength, stretch at break, TEA and tensile stiffness. In addition, eight other industry standard properties can be calculated and reported based on these four basic characteristics.

### Ergonomic design and intuitive user interface

L&W Tensile Tester is designed with attention to ergonomics and efficiency. The table area has been enlarged to make it easier to manage test-pieces, the start button is placed near to the test-piece input and the easy-to-use color touchscreen has intuitive menus and large, easily accessible buttons. Predefined measurement programs can be adapted as required, and the capacitive color touchscreen has a protective surface for easy cleaning and durability with fast response and high resolution.

### Superior clamp design

To ensure that the test-piece is aligned, there are guides on each clamp that rectify the test piece. And with a simple switch, the operator can change

the test width to be used. Further, the L&W Tensile Tester has a proven clamp design, with a cylindrical clamp holding the test-piece in place on a flat surface. The clamps are also totally backlash-free. This design is recommended by both the ISO and TAPPI standards. Plus, for converted products, spans as short as 50 mm can be used for testing between perforation lines.

### Measurement procedure

The test-piece is inserted and positioned correctly with the help of the guides on the clamps. Either the operator presses the easily accessible start button or the measurement starts automatically when the sensors are activated. The clamps close and the test-piece is stretched until it breaks. The clamp then returns to the start position. L&W Tensile Tester measures according to all established standards.

### Measurement results

The measurement results are presented as SI or foot-pound units, on the color touchscreen, either tabular or graphic. The result can also be printed on the optional built-in printer, on a network printer or exported via Ethernet.



01

01  
Load the test-piece. A light sensor detects the test-piece and measurement starts. Conveniently located start button for manual start.



02

02  
After the test-piece breaks, the clamp returns to the start position.

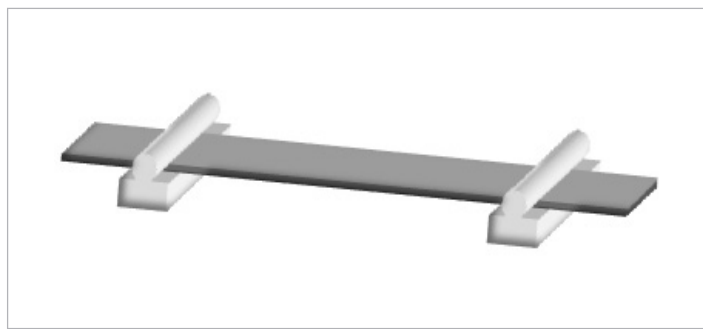

03

03  
Unique clamp design for well-defined tensile tests. Designed in accordance with ISO and TAPPI.

## Benefits

- Ease of use:
  - Auto-start, a photocell detects the presence of a sample, and automatically initiates a measurement sequence
  - Large touchscreen provides good overview
  - Intuitive user interface
- Comfortable testing:
  - The horizontal design creates an ergonomic way to do tensile testing
  - The large table area in front of the clamps makes it easy to handle the test pieces
- High repeatability:
  - Superior clamp design
  - Automatic compensation if the test-piece is not stretched at the beginning of the measurement

## Technical specifications – L&W Tensile Tester, code 066

Inclusive	Built-in thermo printer		
<b>Measurement</b>			
Load cells	50N (11 lbf) 200N (45 lbf) 1000N (225 lbf)		
Stretch at break	370% max at 50 mm (2 in) 135% max at 100 mm (4 in) 30% max at 180 mm (7.1 in)		
<b>Instrument</b>			
Testing velocity	3–100 mm/min (0.12–4 in/min)		
Test span	50 mm, 100 mm and 180 mm (2 in, 4 in and 7.1 in)		
Clamping force	3000 N (675 lbf)		
Test piece width	15, 25 or 50 mm (0.6, 1.0 or 2.0 in) without the need for changing clamps		
<b>Results</b>			
	<b>Measurement values (in SI or FPS units):</b>	<b>Statistics:</b>	
	- tensile strength	- indexed results	
	- max. force	- arithmetic mean value	
	- breaking length	- median value	
	- strain at break	- standard deviation	
	- elongation	- coefficient of variation	
	- elongation at 2/3 of max. force	- MD/CD ratio	
	- tensile energy absorption		
	- tensile stiffness		
	- E-modulus (Young's modulus)		
<b>Connections</b>			
Data	Ethernet The instrument acts as a FTP-server. Test results can be retrieved by a FTP-client.		
<b>Installation requirements</b>			
Power	90 W		
Instrument air	0.6–1 MPa (75–150 psi)		
Option	- available load cells 50N (11 lbf), 200N (45 lbf) or 1000N (225 lbf) - wetting device - integrated notch punch and ISO fracture toughness evaluation		
Dimensions	0.8 × 0.6 × 0.4 m/32 × 24 × 16 in	Volume	0.3 m <sup>3</sup> /11 ft <sup>3</sup>
Net weight	36 kg/80 lb	Gross weight	57 kg/126 lb

## Applicable standards

APPITA/AS 1301.448, PAPTAC D.34, DIN 53112 Teil 1, ISO 1924-2/3, ISO 3781, ISO 12625-4/12, SCAN P38/P67, TAPPI T494, JIS P8113  
With wetting device: ISO 12625-5, TAPPI T456  
With fracture toughness: ISO/TS 17958



04



05



06



07

04

The water level is regulated by using the communicating vessels principle.

05

A dry test-piece is placed between the clamps. The test-piece is then wetted in the soaking vessel.

06

The test-piece is wetted for a predefined number of seconds, and is automatically pulled to break according to a standard tensile test.

07

Wetting device parts.

## OPTION – WET TENSILE TESTING

The wet tensile breaking strength is an important performance characteristic of paper that will be processed wet, or that will be subjected to wetting, whether accidentally or intentionally during use. Example of such products include: tissue products, photographic paper, bags, moisture food wraps, saturating papers, and any other papers subjected to stress during processing or use, while wet.

L&W Tensile Tester is a perfect choice for dry and wet tensile testing of tissue paper. The wetting and tensile test sequence is fully automated. Standard test span for wet tensile testing is normally 100mm. When wet tensile testing, a water soaking vessel is placed between the clamps.

### Measurement procedure

The test-piece is clamped and then the first clamp moves so that the test-piece is automatically immersed into the water soaking vessel. The test-piece is wetted a predefined number of seconds, and is automatically pulled to break according to a standard tensile test. The water level in the soaking vessel is automatically regulated using the communicating vessels principle, with a water bottle beside the instrument.

### Benefits

- Fully automated testing sequence, including test-piece wetting
- Automatic filling and regulation of the water soaking vessel
- Additional test results
  - Wet tensile strength retention
  - Wet tensile strength

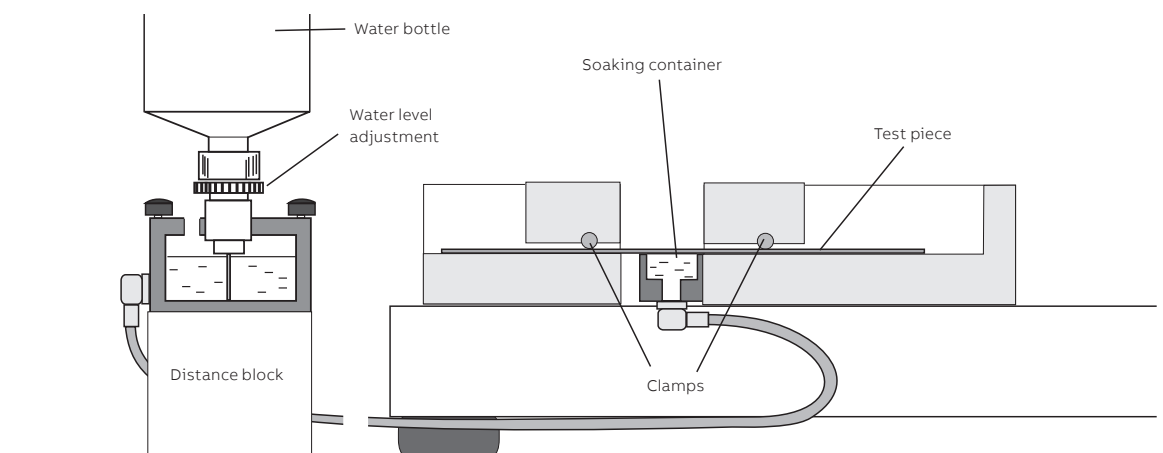

The water level is regulated by using the communicating vessels principle.

## OPTION – NOTCH PUNCH AND FRACTURE TOUGHNESS EVALUATION

Optimum fracture resistance is essential for avoiding cracking and the consequent risk of expensive web breaks in paper machines and printing presses. Good fracture resistance is also important for reducing the risk of cracking, for example, when punching corrugated fibreboard.

L&W Tensile Tester can predict critical strength and strain for large paper webs with some defects such as a small edge cut. What is needed is an integrated notch-punch for making a 20 mm center cut in the test-piece, an anti-buckling guide to keep the test-piece flat during measurement and also a special software that can predict, based on advanced numerical calculation, critical stress and strain for a large web with an edge cut. The instrument uses an evaluation procedure developed by RISE (Research Institutes of Sweden), which is described in ISO TS 17958.

### Measurement procedure

Two series of laboratory tensile testing has to be done: one traditional tensile test series and one fracture toughness test series. Both these tests are performed following ISO 1924-3, with the

exception that 50 mm wide test-pieces containing 20 mm wide center notches are used in the fracture toughness test. The instrument uses the recorded data for numerical calculation to predict the fracture strength and fracture strain of notched paper webs, for a given standard paper web geometry. The standard geometry is a two metre long and one metre wide paper web, containing a 10-millimeter edge cut. This standard geometry can be used to predict and rank the fracture properties of paper materials. The specified methods are based on in-plane fracture mechanics theory (J-integral).

### Benefits

- Integrated notch-punch
- Predicts web breaks
- Additional test results:
  - Measurement values (in SI or FPS units)
  - Fracture toughness
  - Predicted measurements for 2 × 1 meter sample
  - Fracture strength
  - Fracture strain
  - Statistics
  - Confidence limits



Integrated notch punch and anti buckling guide.

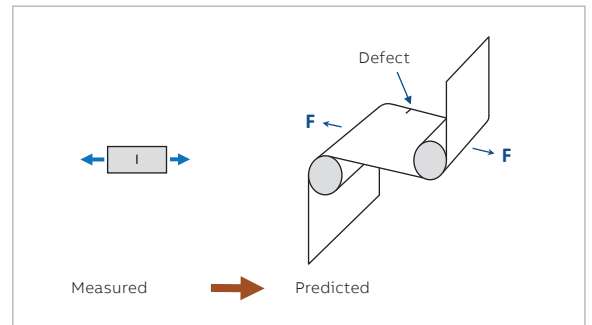

Numerical calculation to predict fracture strength and fracture strain.

