



USER INSTRUCTIONS

***Limitorque LY Series:
LY 1001, LY 2001 and LY 3001***

FCD LMENIM1501-00 – 11/11

***Installation
Operation
Maintenance***

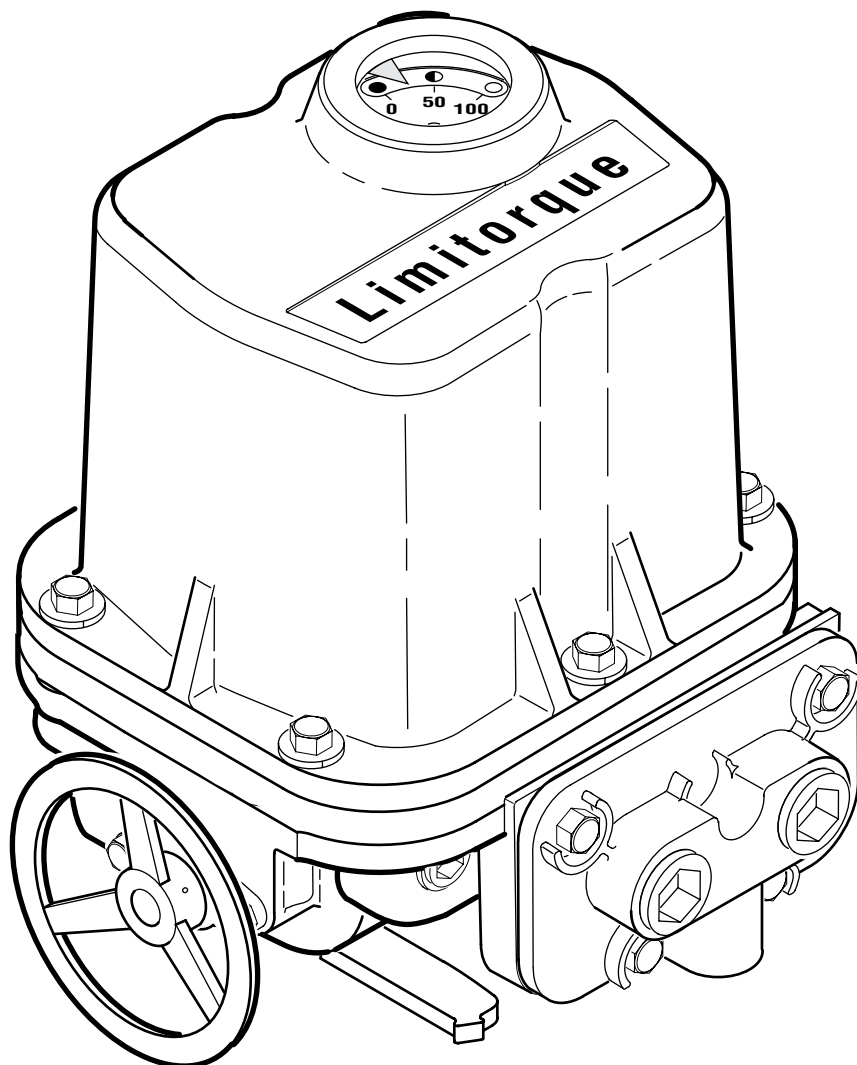



Contents

1	Introduction	5
1.1	Purpose	5
1.2	User Safety	5
2	Product Capabilities and Features	6
3	Initial Inspection and Storage Instructions	7
3.1	Product Identification	7
3.2	Inspection and Recording	8
3.3	Storage Procedures	8
3.3.1	Short-Term Storage (less than 1 year)	8
3.3.2	Long-Term Storage (1 to 5 years)	8
4	Actuator Weights	10
5	Installation Instructions	11
5.1	Safety Precautions	11
5.2	Safety Practices	12
5.3	Initial Actuator Preparation	12
5.4	Installation Overview	14
5.5	Torques Switch Settings	18
5.6	Rewiring the Torque Switch for Non-Standard Drive Sleeve Rotation	18
5.7	Limit Switch and Mechanical Stop Settings	19
5.8	Setting the Limit Switches	19
5.8.1	Setting the CLOSED Limit Switch	19
5.8.2	Setting the OPEN Limit Switch	21
5.9	Mechanical Stops	22
5.9.1	Setting the CLOSED Mechanical Stop on the LY 1001	22
5.9.2	Setting the CLOSED Mechanical Stop on the LY 2001/3001	23
5.9.3	Setting the OPEN Mechanical Stop on the LY 1001	24
5.9.4	Setting the OPEN Mechanical Stop on the LY 2001/3001	24
5.10	Setting the MDPI (Mechanical Dial Position Indicator)	24
5.10.1	Setting the Potentiometer	25
6	Operation	27
6.1	Typical LY 1001 Operation	27
6.2	Verify Correct Motor Rotation (Phasing) and OPEN/CLOSE Pushbutton Operation	27
6.2.1	Three-Phase Motor	28
6.2.2	Single-Phase Motor	32
6.2.3	DC Motor	36
6.3	Electrical Startup	36
6.4	Manual Operation	37
6.5	Motor Operation	37
7	Maintenance	45
7.1	Lubrication	45
7.1.1	Lubrication Inspection	45
7.1.2	Factory Lubricant	46
7.2	Minimum Lubricant Qualities Required	46
7.3	Disassembly and Reassembly	46
7.3.1	LY 1001 Disassembly	46
7.3.2	LY 1001 Reassembly	48
7.3.3	LY 2001/3001 Disassembly	50
7.3.4	LY 2001/3001 Reassembly	52
7.4	Troubleshooting	55
8	Parts List	58
9	How to Order Parts	61
10	Regulatory Information	62

Figures

Figure 2.1 – LY Actuator	6
Figure 3.1 – LY Nameplate	7
Figure 5.1 – Torque Nut and Retaining Drive Ring Removal from an LY 1001	12
Figure 5.2 – LY Keyway Locations	13
Figure 5.3 – LY 1001, 2001, and 3001 Torque Drive Nut Orientation	15
Figure 5.4 – Removing Control Cover and Conduit Pipe Plugs	16
Figure 5.5 – Grounding Lug Location	17
Figure 5.6 – Reversing Torque Switch Wiring	18
Figure 5.7 – Limit Switch Setting Nut	20
Figure 5.8 – Setting CLOSE Limit Cam	20
Figure 5.9 – Setting OPEN Limit Cam	21
Figure 5.10 – Mechanical Stop Set Screw Adjusted to Torque Nut Contact Point on LY 1001	22
Figure 5.11 – Mechanical Stop Set Screw Adjusted to Torque Nut Contact Point on LY 2001 and 3001	23
Figure 5.12 – Aligning MDPI with Dial Window Retaining Plate	25
Figure 5.13 – Potentiometer Calibration Components	26
Figure 6.1 – Standard Actuator/Three-Phase	29
Figure 6.2 – Three-Phase with Control Package	30
Figure 6.3 – Standard Actuator/Single-Phase	33
Figure 6.4 – Single-Phase with Control Package	34
Figure 6.5 – LY 1001 Cover and Associated Parts	38
Figure 6.6 – LY 1001 Top Plate and Associated Parts	39
Figure 6.7 – LY 1001 Housing and Associated Parts	40
Figure 6.8 – LY 2001/3001 Cover and Associated Parts	41
Figure 6.9 – LY 2001/3001 Top Plate and Associated Parts	42
Figure 6.10 – LY 2001/3001 Housing and Associated Parts	43
Figure 6.11 – LY 3001 Handwheel Assembly	44
Figure 7.1 – LY 1001 Declutch Return Spring Installation Position	48
Figure 7.2 – LY 2001/3001 Declutch Return Spring Installation Position	52

Tables

Table 4.1 – Actuator Weights	10
Table 5.1 – Mounting Base Dimensions	13
Table 5.2 – LY Actuator/Mounting Base Tap Sizes	16
Table 5.3 – Control Cover and Conduit Pipe Plug Hardware	16
Table 5.4 – LY Control Cover and Integral Control Cover Bolt Sizes and Torques	17
Table 5.5 – Mechanical Stop Set Screws	22
Table 5.6 – Mechanical Stop and Locknut Screw Sizes	23
Table 8.1 – LY 1001 Parts List	58
Table 8.2 – LY 2001/3001 Parts List	59

1 Introduction

1.1 Purpose

This Installation and Maintenance Manual explains how to install and maintain LY actuators. Information on installation, disassembly, lubrication, and parts is provided.

1.2 User Safety

Safety notices in this manual detail precautions the user must take to reduce the risk of personal injury and damage to the equipment. The user must read and be familiar with these instructions before attempting installation, operation, or maintenance. Failure to observe these precautions could result in serious bodily injury, damage to the equipment, warranty void, or operational difficulty.

Safety notices are presented in this manual in three forms:

⚠ **WARNING:** Refers to personal safety. Alerts the user to potential danger. Failure to follow warning notices could result in personal injury or death.

⚠ **CAUTION:** Directs the user's attention to general precautions that, if not followed, could result in personal injury and/or equipment damage.

NOTE: Highlights information critical to the user's understanding of the actuator's installation and operation.

2

Product Capabilities and Features

The LY actuator controls the opening and closing travel of the valve and limits torque through the torque switches provided. As a result, all valve-operating parts are protected from overload, improper seating, and foreign obstructions.

LY actuators may be mounted on any size valve in almost any position or location.

Microprocessor-based control and monitoring devices are available for installation on your actuator. Contact your local Limitorque distributor or Limitorque sales office for further information.

Figure 2.1 – LY Actuator (LY 1001 shown)

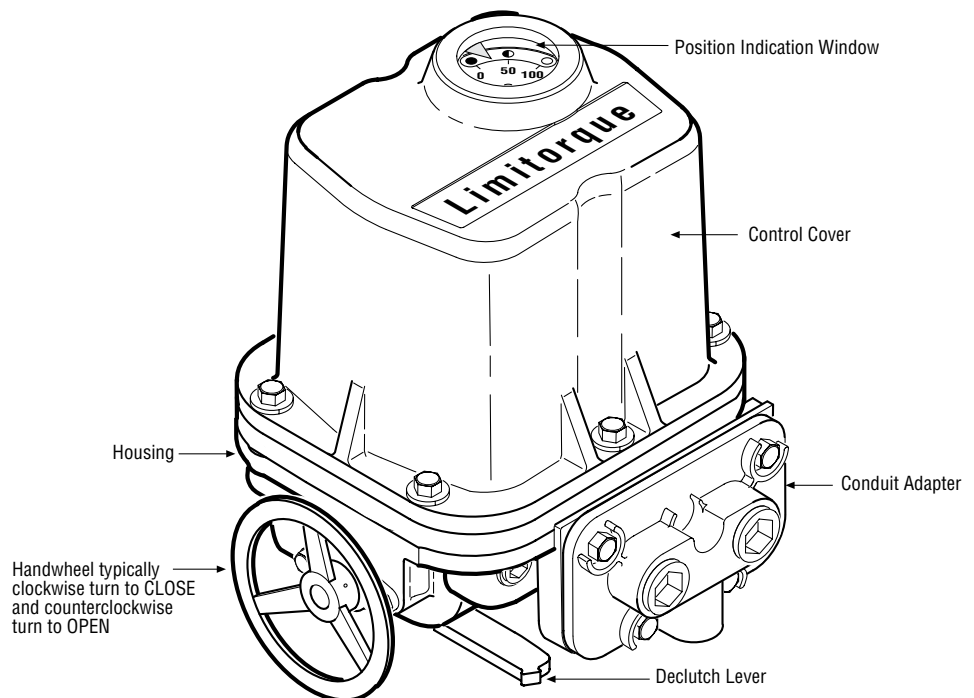

3 Initial Inspection and Storage Instructions

WARNING: Read this Installation and Maintenance Manual carefully and completely before attempting to store the actuator. Be aware of electrical hazards within the actuator and high-pressure hazards of the attached valve or other actuated device when installing or performing maintenance on your LY actuator.

3.1 Product Identification

The actuator unit nameplate is located on the side of the unit opposite the conduit entry. The nameplate contains the following information:

- Limitorque name
- Point of Manufacture
- Unit Size
- Serial Number
- Order Number
- Electrical Power Supply
- Operating Time (seconds)
- Motor Full Load Amperage
- Connection diagram

Figure 3.1 – LY Nameplate (Reference Drawing 61-682-0108)

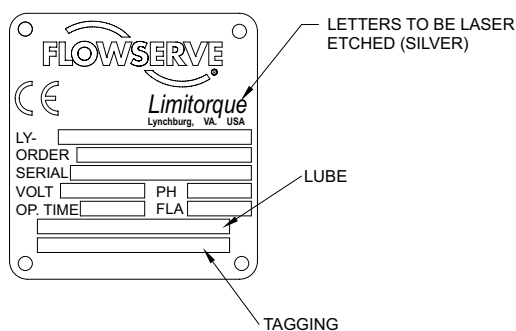

3.2 Inspection and Recording

Upon receipt of the actuator, inspect the condition of the equipment and record nameplate information as follows:

1. Carefully remove actuator from shipping carton or skid. Thoroughly examine the equipment for any physical damage that may have occurred during shipment. If damaged, immediately report the damage to the transport company.
2. Record the unit nameplate information for future reference, i.e., ordering parts, and obtaining further information.

3.3 Storage Procedures

NOTE: The following are Flowserve's recommended storage procedures to retain maximum product integrity during short-term and long-term storage. Failure to comply with recommended procedures will void the warranty.

3.3.1 Short-Term Storage (less than 1 year)

Actuators should be stored in a clean, dry, protected warehouse, free from excessive vibration and rapid temperature changes.

Preparation

1. Connect internal heaters, if supplied.
2. Replace all plastic caps or plugs with metal pipe plugs.
3. Ensure all covers are tight.

Outdoor Storage

If actuators must be stored outdoors, they must be stored off the ground, high enough to prevent being immersed in water or buried in snow.

LY Storage Orientation

- Store with the Control Compartment Cover (Limit Switch compartment) facing upward.
- Do not store units on their side.

3.3.2 Long-Term Storage (1 to 5 years)

Actuators should be stored in a clean, dry, protected warehouse, free from excessive vibration and rapid temperature changes.

NOTE: During long-term storage, the maximum source of equipment deterioration anticipated is from possible condensation within the actuator enclosure. This condensation may occur with rapid temperature changes in the storage environment. If reliable means are not available to prevent rapid temperature changes, a heat source should be added in the electrical enclosure during storage. Consult the Limitorque Customer Service Department for further information.

Preparation

1. Connect internal heaters, if supplied.
2. Replace all plastic caps or plugs with metal pipe plugs.
3. Ensure all covers are tight.

LY Storage Orientation

1. Store with the Control Compartment Cover (Limit Switch compartment) facing upward. Do not store units on their side.
2. Store off the floor on suitable skids and cover with an unsealed dust cover leaving the bottom open and air holes in the side.

Storage Inspection and Correction

1. Perform a semi-annual visual inspection. A minimum inspection should include checking the following:
 - Packaging
 - Plugs
 - Covers
 - Dryness
 - Cleanliness
 - Heat source (if used) for proper functioning
2. Record and correct deficiencies noted during inspection.

4 Actuator Weights

The approximate LY actuator weights are provided below.

Table 4.1 – Unit Weights

Unit Size	Control Types	Weight	
		lb.	kg
LY 1001	NCU	40	20
	BIC	75	34
	UEC	90	41
LY 2001	NCU	100	45
	BIC	110	50
	UEC	144	65
LY 3001	NCU	105	48
	BIC	130	59
	UEC	149	68

5

Installation Instructions

5.1 Safety Precautions

- ⚠ **WARNING:** Read this Installation and Maintenance Manual carefully and completely before attempting to install, operate, or troubleshoot the Limitorque actuator.
- ⚠ **WARNING:** Be aware of electrical hazards. Turn off incoming power before working on the actuator and before opening the switch compartment.
- ⚠ **WARNING:** Potential HIGH PRESSURE vessel — be aware of high-pressure hazards associated with the attached valve or other actuated device when installing or performing maintenance on the actuator. Do not remove the actuator mounting bolts from the valve or actuated device unless the valve or device stem is secured or there is no pressure in the line.
- ⚠ **WARNING:** For maintenance and/or disassembly of the actuator while installed on the valve, ensure that the actuator is not under thrust or torque load. If the valve must be left in service, the valve stem must be locked in such a way as to prevent any movement of the valve stem.
- ⚠ **WARNING:** Do not manually operate the actuator with devices other than the installed hand-wheel and declutch lever. Using force beyond the ratings of the actuator and/or using additive force devices such as cheater bars, wheel wrenches, pipe wrenches, or other devices on the actuator handwheel or declutch lever may cause serious personal injury and/or damage to the actuator and valve.
- ⚠ **WARNING:** Do not exceed any design limitations or make modifications to this equipment without first consulting Limitorque.
- ⚠ **WARNING:** Actuators equipped with electrical devices (motors, controls) requiring field wiring must be wired and checked for proper operation by a qualified tradesman.
- ⚠ **WARNING:** Use of the product must be suspended any time it fails to operate properly.

- ▲ **CAUTION:** Do not operate the valve under motor operation without first setting or checking the limit switch setting and motor direction.
- ▲ **CAUTION:** Do not force the declutch lever into the motor operation position. The lever returns to this position automatically when the motor is energized.
- ▲ **CAUTION:** Do not depress the declutch lever during motor operation to stop valve travel.
- ▲ **CAUTION:** Do not use replacement parts that are not genuine Flowserve Limitorque parts, as serious personal injury and/or damage to the actuator and valve may result.
- ▲ **CAUTION:** Do not lift the actuator by handwheel.

5.2 Safety Practices

The following check points should be performed to maintain safe operation of the LY actuator:

- Keep the switch compartment clean and dry.
- Keep the valve stem clean and lubricated.
- Set up a periodic operating schedule for infrequently used valves.
- Verify all actuator wiring is in accordance with the applicable wiring diagram.
- Carefully check for correct motor rotation direction. If the valve closes when open button is pushed, the motor leads may have to be reversed.

5.3 Initial Actuator Preparation

Piece numbers refer to Figure 5.1.

1. Remove the Retaining Drive Ring (piece #165 or #109) and Torque Nut (piece #32) from actuator.

Figure 5.1 – Torque Nut and Retaining Drive Ring Removal from an LY 1001

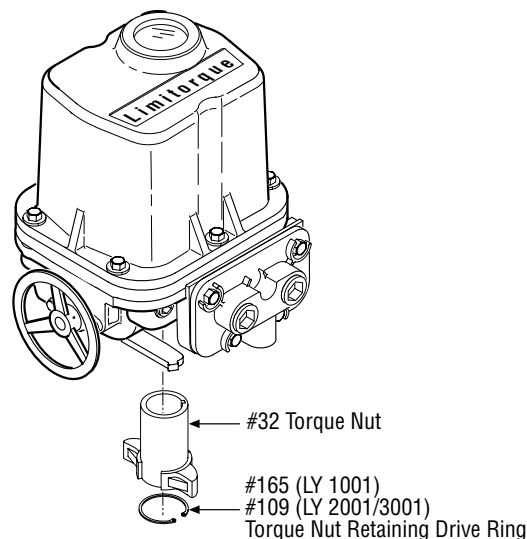

2. If Torque Nut has been bored and keywayed by Limitorque, verify dimensions and keyway location for proper compatibility with the valve stem.
3. If Torque Nut has not been bored and keywayed by Limitorque, it is provided solid (blank) to allow customer to custom key and bore up to the maximum permissible sizes as listed in Table 5.1.

Table 5.1 – Mounting Base Dimensions

Unit Type and Size	Maximum Bore inch (mm)	Maximum Keyway inch (mm)
LY 1001	1-1/8, dia (28 dia)	1/4 x 1/8, (6 x 3)
LY 2001/3001	2-3/8, dia (60 dia)	5/8 x 1/16 (15 x 7.5)

NOTE: Before keywaying, match the Torque Nut with the Valve Stem to ensure proper keyway location. Use the Keyway Index Mark (LY 1001 only) for locating appropriate keyway location.

Figure 5.2 – LY Keyway Locations

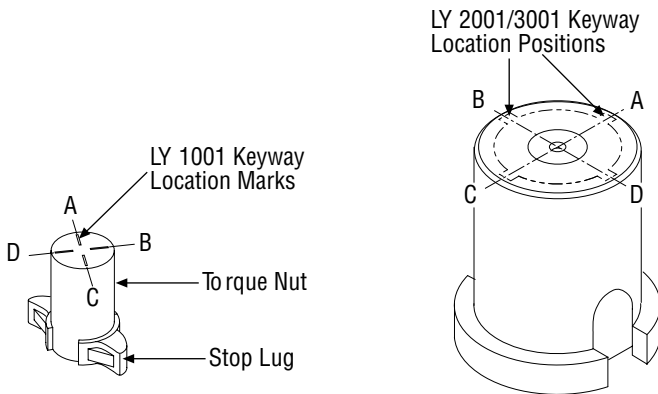

5.4 Installation Overview

- ▲ **CAUTION:** Be sure to complete each step of the installation overview before electrically operating your actuator. If the actuator is already mounted to a valve from the manufacturer, verify that the actuator is mounted according to the following overview. Failure to follow the installation procedures could result in personal injury and/or improper operation and could cause damage to the equipment.
1. Mount Torque Nut (piece #32) in the actuator as shown in Figure 5.3 with the following alignment:
 - A. For LY 1001 – Stop Lugs facing the Actuator Mounting Adapter with index lines positioned to face the Mechanical Stop Screws.
 - B. For LY 2001/3001 – Torque Nut axially aligned on the Drive Sleeve so that the bottom of the nut is positioned inside the Actuator Mounting Base.
 2. Insert the Retaining Drive Ring (piece #165 for LY 1001, piece #109 for LY 2001/3001) on the Torque Nut (piece #32) to hold the Torque Nut in place in the actuator.
 3. Mount the LY actuator on the mounting flange of the valve or other actuated equipment. High-strength (minimum SAE-Grade 5 120,000 psi tensile strength) hex head or socket head cap screws with lockwashers are recommended. The actuator mounting tap quantities and thread sizes are detailed in Table 5.2.

Figure 5.3 – LY 1001, 2001, and 3001 Torque Drive Nut Orientation

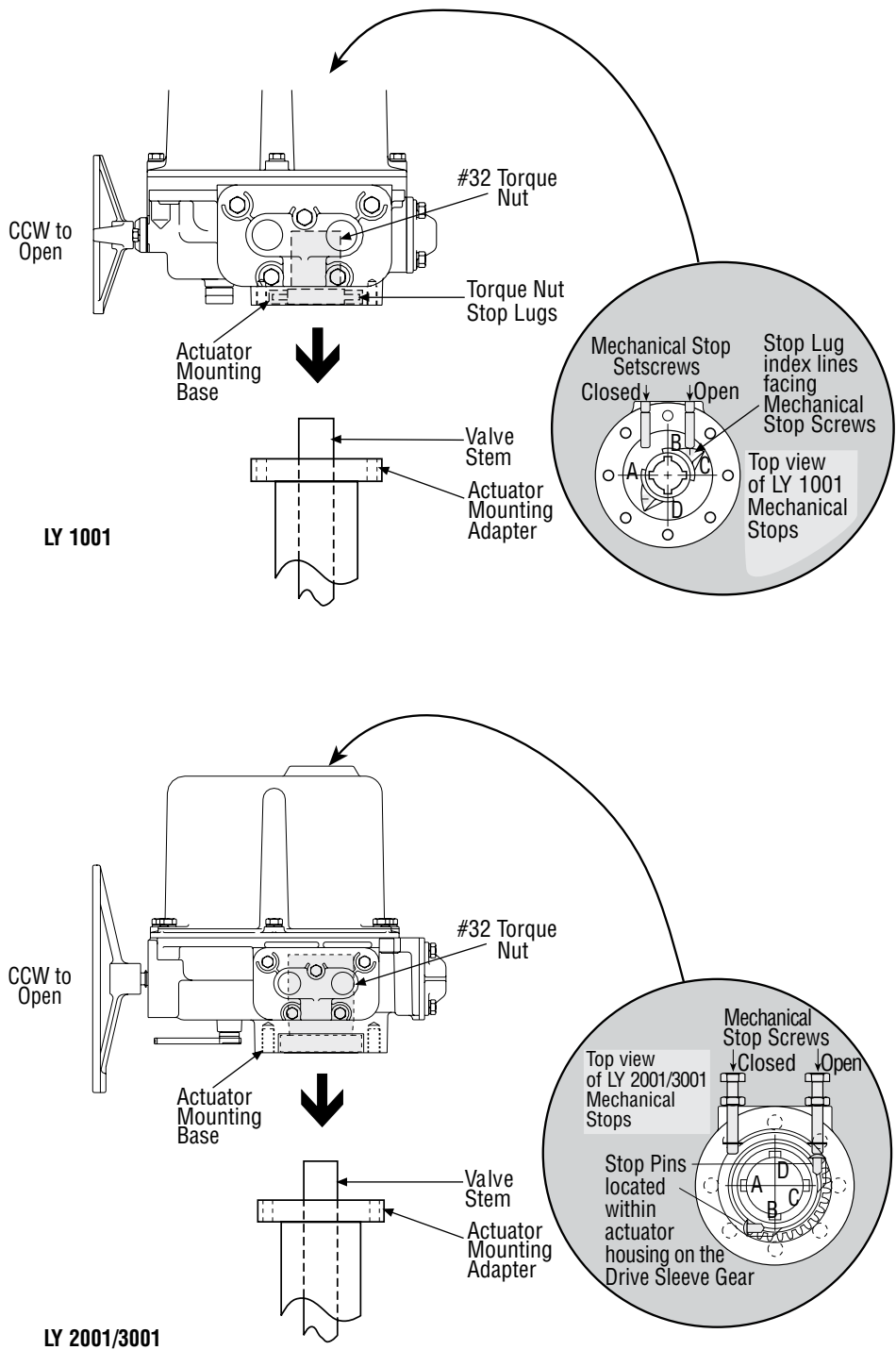

Table 5.2 – LY Actuator/Mounting Base Tap Sizes

Unit Type and Size	Qty	Tap Size	
		English	Metric
LY 1001	8	3/8-16 x 0.71 deep	M10 x 1.5 mm x 25 mm deep (Complies with F10 ISO mounting flange criteria)
LY 2001/3001	8	5/8-11 x 1.26 deep	M16 x 2 mm x 35 mm deep (Complies with F10 ISO mounting flange criteria)

NOTE: Flowserve has supplied eight taps for the LY 1001, LY 2001, and LY 3001 in English/Metric units to provide flexibility in mounting arrangements. A minimum of four securing bolts is required to properly secure and retain torque reaction on these units.

⚠ **WARNING: HAZARDOUS VOLTAGE.** No electrical power should be connected until all wiring and limit switch adjustments have been completed. Once power is supplied to unit, exercise caution if cover is not installed.

- Remove the Control Cover (piece #3) and Conduit Pipe Plugs (piece #144).

Figure 5.4 – Removing Control Cover and Conduit Pipe Plugs

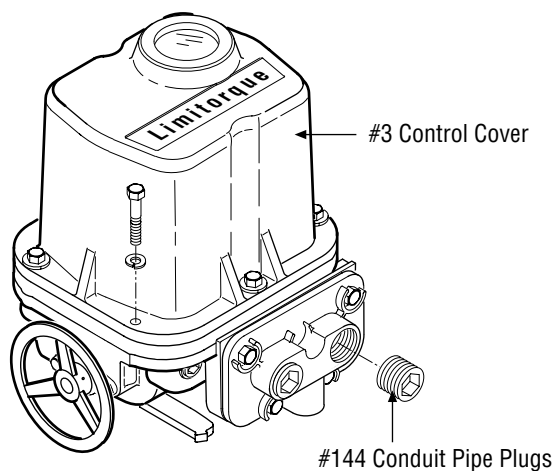

Table 5.3 – Control Cover and Conduit Pipe Plug Hardware

Unit Type	Control Cover		Conduit Pipe Plug	
	Quantity	Size	Quantity	Size
LY 1001 (WP & XP)	6	M8 x 40 mm	2	1" NPT Socket Hex Head
LY 2001/3001	8	M12 x 50 mm (WP) M12 x 55 mm (XP)	2	1" NPT Socket Hex Head

5. Adjust the Limit Switches, Mechanical Stops, and Position Indication Dial following the procedures detailed in Section 5.7, Limit Switch and Mechanical Stop Settings.
6. Connect the wiring to the terminal strips provided on the actuator. Refer to the wiring diagram supplied with the actuator. “Fork-type” terminal connections are recommended.
7. Insert a Conduit Pipe Plug in the unused conduit entrance if the wiring that enters the actuator uses only one conduit entrance.

NOTE:

- a. Explosionproof actuators require approved “sealing fittings” installed in accordance with the National Electric Code.
 - b. Submersible actuators require an approved “sealing fitting” in order to keep water from entering the actuator.
8. Attach grounding wire to Grounding Lug (piece #141).
 9. Verify motor rotation direction to ensure that the limit switch is wired properly for intended operation. (See Section 6.2, Verify Correct Motor Rotation (Phasing) and OPEN/CLOSE Pushbutton Operation.)

Figure 5.5 – Grounding Lug Location

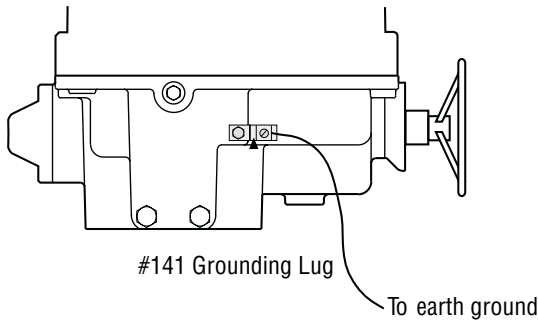

10. Reinstall Control Cover (piece #3).

NOTE: Submersible actuators require tightening the Control Cover Bolts and Integral Control Cover Bolts to a specified torque in order to maintain submersibility. (See Table 5.4 for specific torque settings.)

Table 5.4 – LY Control Cover and Integral Control Cover Bolt Sizes and Torques

Unit Type	Control Cover	Integral Compartment
LY 1001	M8 - 10 to 15 ft-lb	M10 - 15 to 20 ft-lb
LY 2001/3001	M12 - 20 to 25 ft-lb	M10 - 15 to 20 ft-lb

Unit is now ready for electrical operation.

5.5 Torque Switch Settings

⚠ **WARNING:** HAZARDOUS VOLTAGE. Turn power OFF before opening the Electrical Compartment Cover or making any adjustments to the Torque Switch.

▲ **CAUTION:** Installing or adjusting the Torque Switch with the actuator in a loaded condition will result in loss of torque protection. Before adjusting or installing the Torque Switch, place the actuator in MANUAL mode and turn the Handwheel in the direction necessary to release the torque load on the Wormshaft Assembly.

NOTE: Removal or modification of the Torque Switch Limiter Plate will void the actuator warranty. Do not exceed the torque setting indicated by the Torque Switch Limiter Plate without contacting the Limitorque Service Department.

The LY unit is equipped with a do W to MEDIUM or HIGH by adjusting the Torque Switch Adjustment Screw unless it is limited by the Limiter Plate. (See Figure 5.6 for Torque Switch Adjustment Screw location.)

5.6 Rewiring the Torque Switch for Non-Standard Drive Sleeve Rotation

▲ **CAUTION:** Double-check the wiring diagram to verify that the Torque Switch is wired appropriately for the application. The Torque Switch will not protect the valve from over-torque if the Torque Switch is not wired properly for the application.

LY series actuators are typically supplied with a CCW Drive Sleeve rotation to open a valve. The Torque Switch is marked OPEN (CCW) and CLOSE (CW) based upon CW Drive Sleeve rotation to close the valve. The Mechanical Dial Position Indicator (MDPI) is typically mounted for CW rotation to indicate the CLOSED position. If opposite Drive Sleeve rotation is required (CCW to close a valve), the following Torque Switch modifications are required.

1. Turn all power to the actuator OFF.
2. Reverse the ID Limiter Plate.
3. Interchange OPEN Torque Switch wires 18 and 18C with CLOSED wires 17 and 17C. (Refer to the wiring diagram for other Torque Switch wiring configurations.)

Figure 5.6 – Reversing Torque Switch Wiring

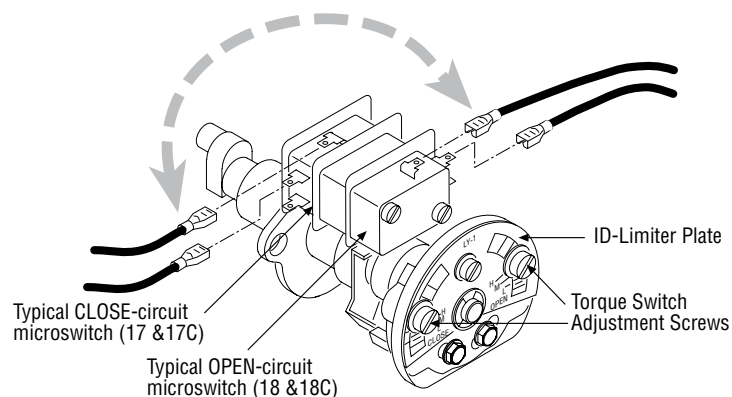

4. Remove the MDPI Plate and flip over for indication of CCW rotation to the valve's closed position. (See Figure 5.12 for MDPI Dial Plate.)

5.7 Limit Switch and Mechanical Stop Settings

The Limit Switch and Mechanical Stops are not preset at the factory, but must be set after mounting on the associated equipment. If the actuator has been shipped already installed on a valve, the actuator should have the Limit Switch and Mechanical Stops set for your application. If the actuator is not already installed on a valve or needs resetting, use the following instructions to make the appropriate settings.

The following instructions for setting the Limit Switches and Mechanical Stops are based on the typical orientation for most actuator applications. Consult the applicable wiring diagram located in the Control Compartment for the specific Limit Switch development.

NOTE: While making Limit Switch settings, remember that the Limit Cams rotate in the same direction as the valve stem.

5.8 Setting the Limit Switches

- ⚠ **WARNING:** Do not manually operate actuator with devices other than installed Handwheel and Declutch Lever. Using additive force devices (cheater bars, wheel wrenches, pipe wrenches or other devices of this nature) on the actuator Handwheel or Declutch Lever may cause serious personal injury and/or damage to the actuator or valve.
- ⚠ **WARNING:** HAZARDOUS VOLTAGE. Make sure all power is disconnected before making the following settings.

5.8.1 Setting the CLOSED Limit Switch

1. Put the actuator in MANUAL operation: move the Declutch Lever in the direction of the arrow on the lever until the Declutch Lever locks in place. If Declutch Lever is difficult to move, see Section 6.4, Manual Operation for instructions to release the Declutch Lever.
2. Turn the Handwheel CW to move the valve to the full CLOSE position.

NOTE: Most applications require turning the Handwheel CW to obtain the full CLOSE position and CCW to obtain full OPEN position. The Drive Sleeves and Limit Cams also rotate in CW rotation to the CLOSE position and CCW to the OPEN position. If the application is configured differently, the descriptions in this manual will describe rotation directions opposite your application.

3. Loosen Setting Nut (piece #7-10) located at the top of the switch bracket approximately $\frac{3}{4}$ turn.

NOTE: When setting the Limit Cams by rotating to the trip point as described in Step 4, be careful not to move more than one cam at a time. Limit Cams that have already been set are not secure until Setting Nut (piece #7-10) is retightened.

Figure 5.7 – Limit Switch Setting Nut

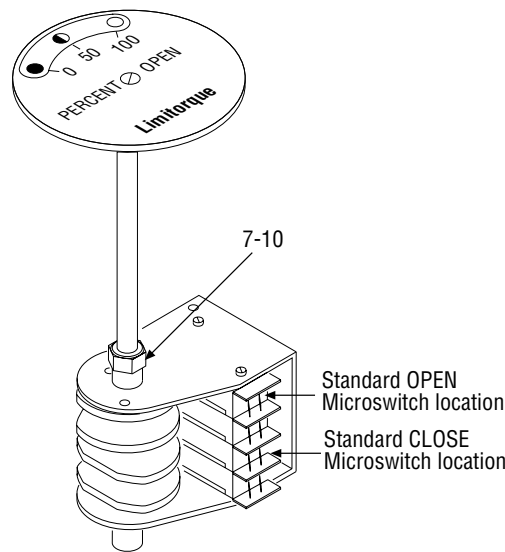

4. Rotate the CLOSE Limit Cam CW through the high side to the trip point until the Switch Plunger is released. This causes the N.O. (normally open) contact to open.

NOTE: There will be no electrical continuity at the trip point when measuring with an ohmmeter between the common lead and the N.O. lead. You may also hear a faint “click” at the trip point.

NOTE: During actuator operation, when the Switch Plunger trips, the N.O. contact is released, causing the Limit Switch to stop the actuator in the CLOSED position.

Figure 5.8 – Setting CLOSE Limit Cam

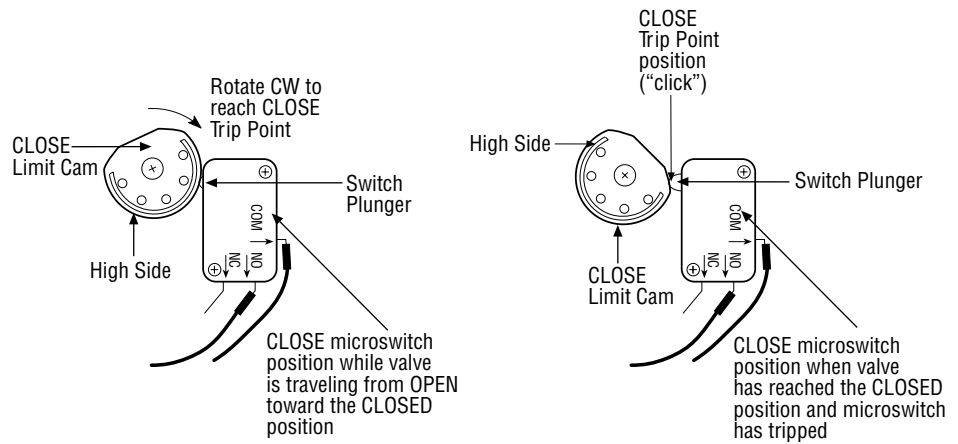

5. Retighten Setting Nut (piece #7-10).

5.8.2 Setting the OPEN Limit Switch

NOTE: When setting the OPEN Limit Switch, be careful not to rotate the CLOSE Limit Cam; rotating it will change the adjustments you previously made on the CLOSE Limit Switch.

1. Put the actuator into MANUAL operation by moving the Declutch Lever in the direction of the arrow on the lever until the Declutch Lever locks in place. If Declutch Lever is difficult to move, see Section 6.4, Manual Operation for instructions to release the Declutch Lever.
2. Turn the Handwheel to move the valve to the full OPEN position.

NOTE: Most applications require turning the Handwheel CCW to obtain the full OPEN position. The Drive Sleeve and Limit Cams also rotate in CCW rotation to the OPEN position. If your application is configured differently, keep in mind the descriptions in this manual will describe rotation directions opposite of your application.

3. Loosen Setting Nut (piece #7-10) located at the top of the switch bracket. (See Figure 5.7.)
4. Rotate the OPEN Limit Cam CCW through the high side to the trip point until the Switch Plunger is released. This causes the N.O. contact to open. There will be no electrical continuity at the trip point when measuring with an ohmmeter between the common lead and the N.O. lead; you may also hear a faint “click” at the trip point.

NOTE: During actuator operation, when the Switch Plunger trips, the N.O. contact is released, causing the Limit Switch to stop the actuator in the OPEN position.

Figure 5.9 – Setting OPEN Limit Cam

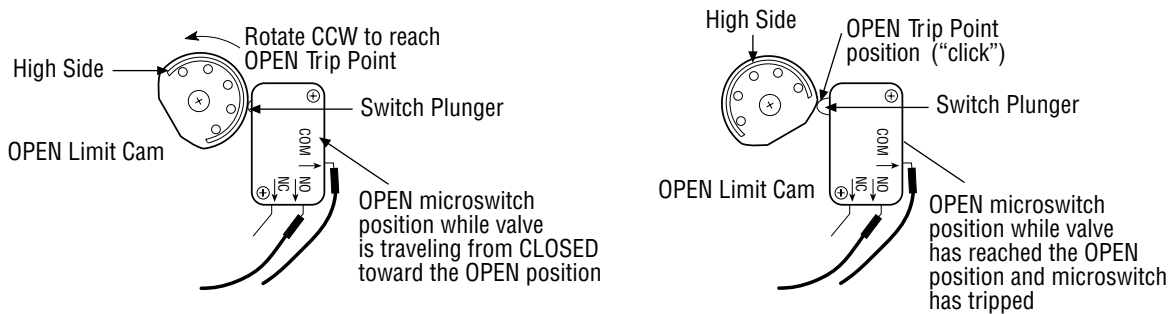

5. Retighten Setting Nut (piece #7-10).

5.9 Mechanical Stops

5.9.1 Setting the CLOSED Mechanical Stop on the LY 1001

Table 5.5 – Mechanical Stop Set Screws

Unit Type	Mechanical Stop Set Screw Size	Set Screw Size
LY 1001	3/8-16 x 1.25"	3/8-16 x 0.375"

Piece numbers refer to Figure 5.10.

1. Set CLOSE Mechanical Stop Set Screw (piece #58) by removing the Set Screw (piece #59).
2. Using the Handwheel, turn the valve to the CLOSE position. Make sure the valve is fully seated before setting the mechanical stop.
3. Rotate Mechanical Stop Set Screw (piece #58) in the CW direction until contact with the Torque Nut (piece #32) occurs. (See Figure 5.9.)
4. Back-off Mechanical Stop Set Screw (CCW direction) approximately 1½ turns.
5. Reinstall Set Screw (piece #59).
6. Manually operate the actuator through the close limit to assure setting is correct.

NOTE: The Mechanical Stops are intended to protect the equipment from overtravel if a Limit Switch fails. The valve should not torque-out against the Mechanical Stop Set Screw during normal OPEN/ CLOSE cycles.

Figure 5.10 – Mechanical Stop Set Screw Adjusted to Torque Nut Contact Point on LY 1001

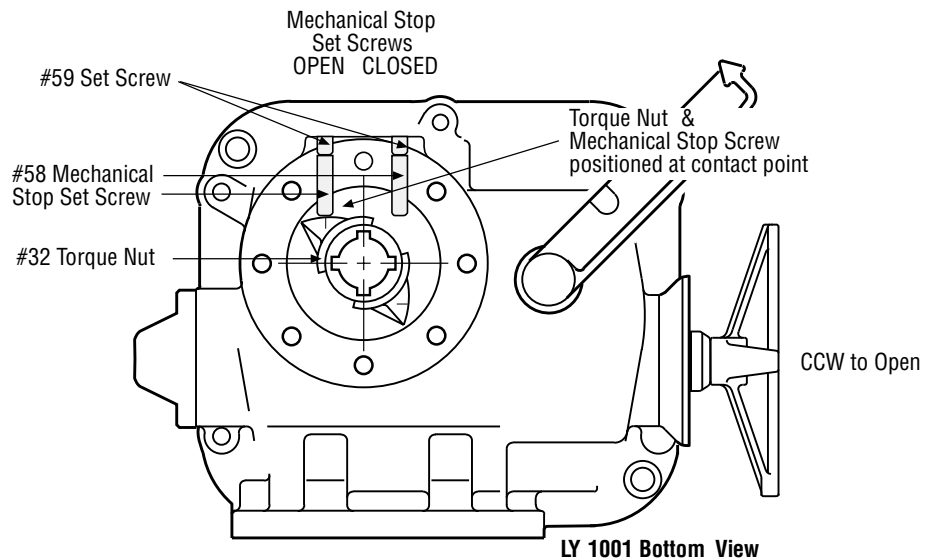

5.9.2 Setting the CLOSED Mechanical Stop on the LY 2001/3001

Table 5.6 – Mechanical Stop and Locknut Screw Sizes

Unit Type	Stop Screw Size	Locking Nut Size
LY 2001/3001	5/8-16 x 3"	5/8-11

All piece numbers refer to Figure 5.11.

1. Set CLOSE Mechanical Stop Screws (piece #58) (Hex Head Cap Screw) by loosening Locking Nut (piece #59) (Hex Head Nut).
2. Using the Handwheel, turn the valve to the CLOSE position. Make sure the valve is fully seated before setting the mechanical stop.
3. Rotate Mechanical Stop Screw (piece #58) in the CW direction until contact with the Stop Pin (piece #28) occurs.
4. Back-off Mechanical Stop Screw (CCW direction) approximately 1½ turns.
5. Retighten Locking Nut.
6. Manually operate the actuator through the close limit to assure setting is correct.

NOTE: The Mechanical Stops are intended to protect the equipment from overtravel if a Limit Switch fails. The valve should not torque-out against the Mechanical Stop Screw during normal OPEN/CLOSE cycles.

Figure 5.11 – Mechanical Stop Set Screw Adjusted to Torque Drive Nut Contact Point on LY 2001 and 3001

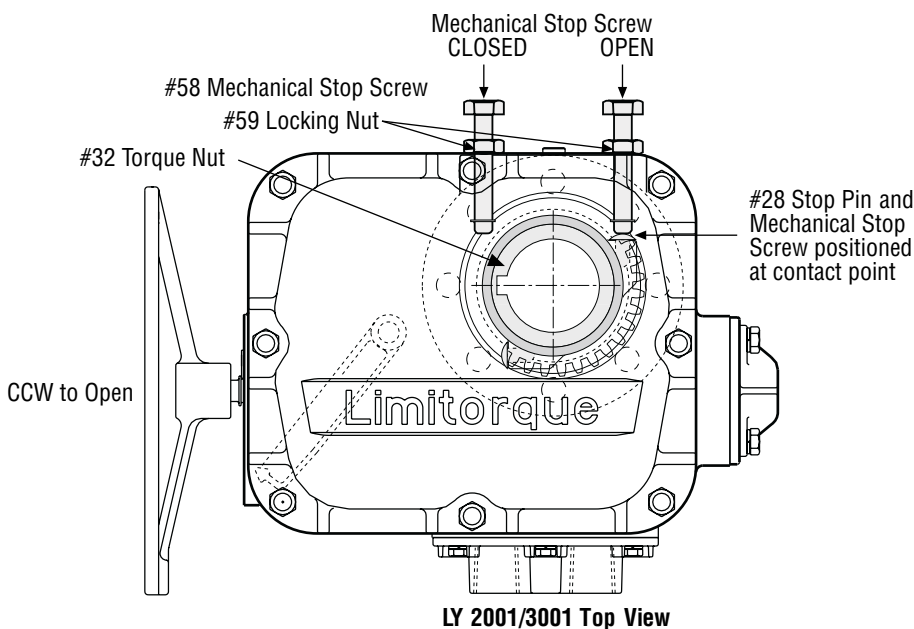

5.9.3 Setting the OPEN Mechanical Stop on the LY 1001

Piece numbers refer to Figure 5.10.

1. With the valve in the full OPEN position, set OPEN Mechanical Stop Set Screw (piece #58) by removing the Set Screw (piece #59). (See Figure 5.9 for orientation.)
2. Using the Handwheel, turn the valve to the OPEN position. Verify the valve is fully open before setting the Mechanical Stop Set Screw.
3. Rotate Mechanical Stop Set Screw (piece #58) in the CW direction until contact with the Torque Nut (piece #32) occurs.
4. Back-off Mechanical Stop Set Screw (CCW direction) approximately 1½ turns.
5. Reinstall Set Screw (piece #59).
6. Manually operate the actuator through the open limit to assure setting is correct.

5.9.4 Setting the OPEN Mechanical Stop on the LY 2001/3001

Piece numbers refer to Figure 5.11.

1. With the valve in the full OPEN position, set OPEN Mechanical Stop Screws (piece #58) (Hex Head Cap Screw) by loosening Locking Nut (piece #59) (Hex Head Nut). (See Figure 5.10 for orientation.)
2. Using the Handwheel, turn the valve to the OPEN position. Make sure the valve is fully open before setting the Mechanical Stop.
3. Rotate Mechanical Stop Screw (piece #58) in the CW direction until contact with the Stop Pin (piece #28) occurs.
4. Back-off Mechanical Stop Screw (CCW direction) approximately 1½ turns.
5. Retighten Locking Nut.
6. Manually operate the actuator through the open limit to assure setting is correct.

NOTE: The Mechanical Stops are intended to protect the equipment from overtravel if a Limit Switch fails. The valve should not torque-out against the Mechanical Stop Screw during normal OPEN/ CLOSE cycles.

5.10 Setting the MDPI (Mechanical Dial Position Indicator)

Piece numbers refer to Figure 5.12.

1. After setting the Limit Switch and Mechanical Stop Settings, manually position the valve in the fully CLOSED position.
2. Loosen Screw (piece #147) on MDPI.
3. Make sure the MDPI Dial Plate (piece #146) is aligned properly with the Dial Window Retaining Plate Arrow (piece #108), usually 0% (CLOSED) should align with the arrow. (See Figure 5.12.)

NOTE: If your application uses CW handwheel rotation to OPEN, flip the MDPI Plate over to properly orient the OPEN and CLOSED position on the MDPI Plate.

- Retighten the Screw (piece #147) on the MDPI Dial Plate (piece #146).

Figure 5.12 – Aligning MDPI with Dial Window Retaining Plate

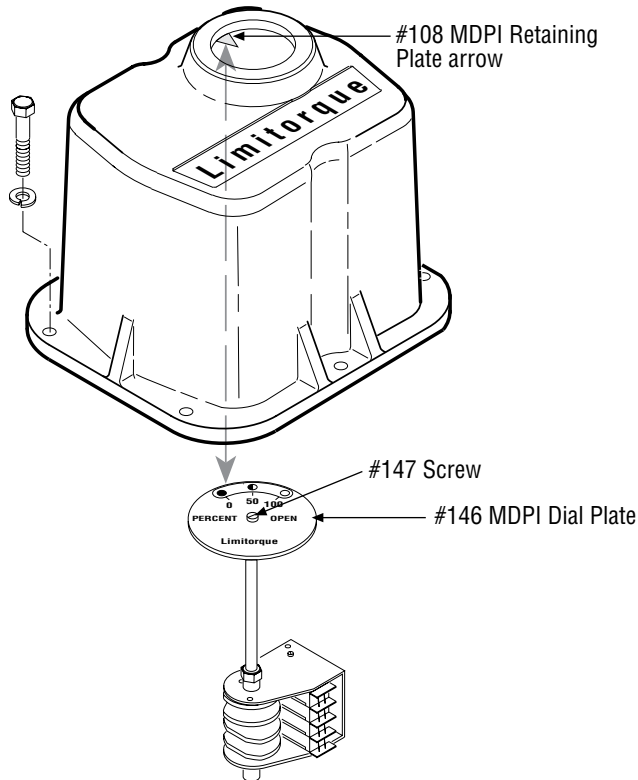

5.10.1 Setting the Potentiometer

If the LY actuator includes a Feedback Potentiometer used for remote valve position indication, use an ohmmeter to calibrate the position of the potentiometer.

⚠ WARNING: HAZARDOUS VOLTAGE. Turn power off before calibrating the Feedback Potentiometer.

- Using the Handwheel, position the actuator to mid-travel (valve at the 50% position).
- Disconnect the Potentiometer Wiring Harness from where it is plugged in or connected to a Terminal Strip.
- Using an ohmmeter, verify that the potentiometer is in mid-travel. The resistance from each End Connection to the Center Connection should be half of the full resistance of the Potentiometer. Example: 1000 ohm potentiometer should read approximately 500 ohms from one of the End Connections to the Center Connection.

Figure 5.13 – Potentiometer Calibration Components

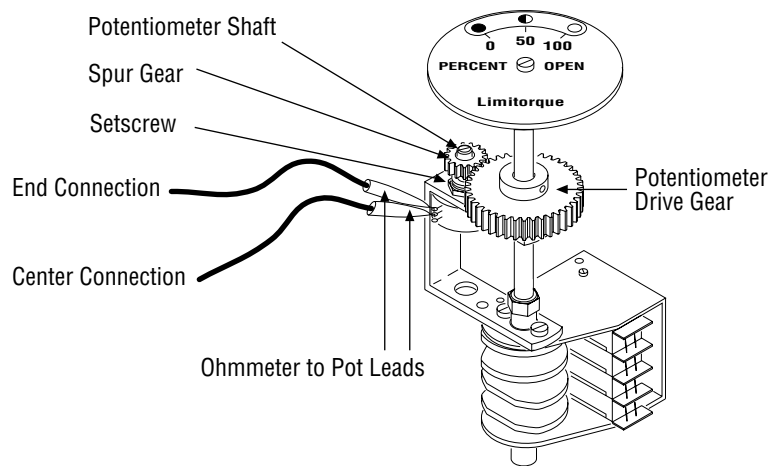

4. If the reading is not correct, proceed to Step 5. If the reading is correct, proceed to Step 6.
5.
 - a. Loosen the small Set Screw that retains the Spur Gear to the Potentiometer Shaft.
 - b. Using a small flat-tipped screwdriver in the slotted Potentiometer Shaft, rotate the Shaft until the correct reading is obtained as described in Step 3.
 - c. Retighten the Set Screw.
6. Disconnect the ohmmeter and reconnect the Potentiometer wiring to the original connection.

6 Operation

6.1 Typical LY 1001 Operation

LY actuators are always available for motor operation when the motor is energized.

NOTE: Applied voltage rating = voltage rating of actuator $\pm 10\%$

- ⚠ **WARNING:** Do not manually operate the actuator with devices other than installed Handwheel and Declutch Lever. Using force beyond the ratings of the unit and/or using additive force devices such as cheater bars, wheel wrenches, pipe wrenches, or other devices on the actuator Handwheel or Declutch Lever may cause serious personal injury and/or damage to the actuator or valve.

- ⚠ **CAUTION:** Do not motor-operate the valve without first setting or checking the limit switch setting, motor direction, and mechanical stops. Do not force the Declutch Lever into the motor operation position. The Declutch Lever returns to motor-operation position automatically when the motor is energized.

6.2 Verify Correct Motor Rotation (Phasing) and OPEN/CLOSE Pushbutton Operation

Correct motor rotation must be verified to prevent serious damage to valve or other equipment. If the actuator motor rotates in the wrong direction, damage could occur by over-torquing equipment into a seated position.

Prior to being shipped from the factory, each actuator is inspected to verify proper operation of the Torque and Position Limit Switches and to ensure that they function correctly, i.e., closes when the CLOSE pushbutton is depressed, opens with the OPEN pushbutton, etc. These inspections are made with a properly phased power source connected as described in the actuator manual.

- ⚠ **CAUTION:** To ensure proper operation and to prevent your actuator or other actuated equipment from damage, verify that your unit is properly connected to its power source.

6.2.1 Three-Phase Motor

NOTE: Your application may vary from the standard wiring configuration for three-phase shown in Figures 6.1 and 6.2. Refer to the specific actuator wiring diagram for wiring configuration.

1. Using the Handwheel, move the valve to a midtravel position. Midtravel position allows brief electrical operation in the valve “safe” area and keeps the OPEN and CLOSED Limit Switches from tripping while testing motor direction.
2. Test motor direction by momentarily pressing the OPEN pushbutton:
 - a. If the actuator moves toward CLOSED, immediately turn all power OFF and reverse the motor leads T1 and T3 on terminal strip.
 - b. If the actuator moves toward OPEN, the motor is wired properly for the application.

Figure 6.1 – Standard Actuator/Three-Phase

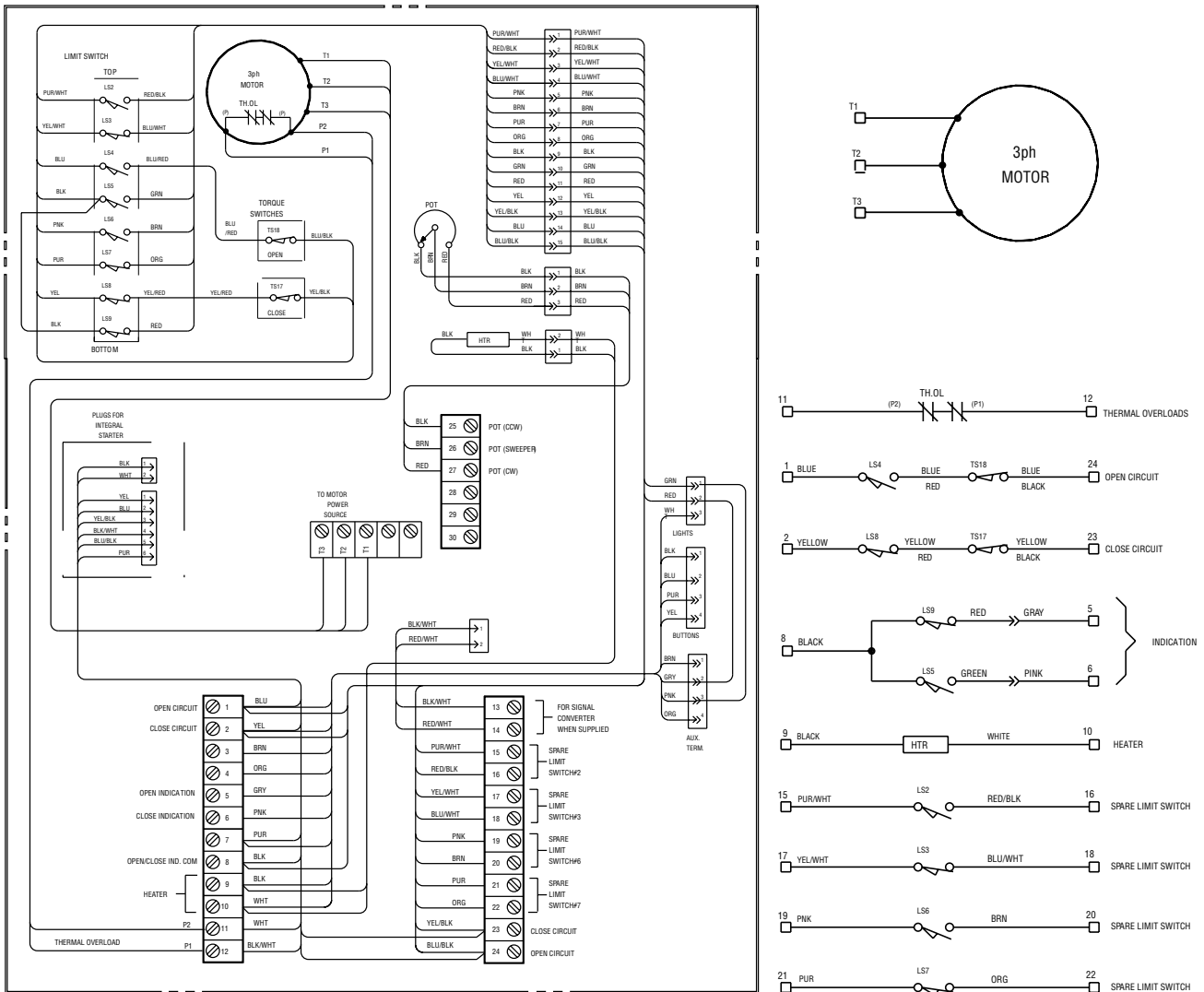

Valve shown in full open position

LIMIT SWITCH CONTACT	VALVE POSITION		FUNCTION
	FULL OPEN	FULL CLOSE	
2	---	█	SPARE
3	█	---	SPARE
4	█	█	OPEN LIMIT
5	█	█	IND LIGHT
6	---	█	INDICATION
7	█	---	INDICATION
8	█	---	CLOSED LIMIT
9	█	---	IND LIGHT

TS17 —Closing torque switch interrupts control circuit if mechanical overload occurs during closing cycle.

TS18 —Opening torque switch interrupts control circuit if mechanical overload occurs during opening cycle.

NOTES

1. --- Open contact
2. █ Close contact
3. All limit switch trip points are fully adjustable.

LEGEND

TH. OL - Thermal Overload Contacts
HTR - Space Heater
Pot - Slider wire transmitter

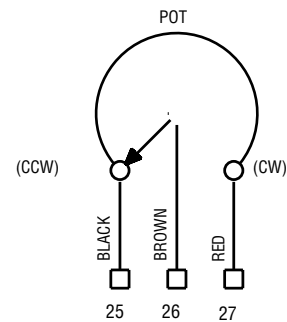

Figure 6.2 – Three-Phase with Control Package

Valve shown in full open position

LIMIT SWITCH CONTACT	VALVE POSITION		FUNCTION
	FULL OPEN	FULL CLOSE	
2	---	█	SPARE
3	█	---	SPARE
4	---	█	OPEN LIMIT
5	---	█	IND LIGHT
6	---	█	INDICATION
7	█	---	INDICATION
8	█	---	CLOSED LIMIT
9	█	---	IND LIGHT

TS17 — Closing torque switch interrupts control circuit if mechanical overload occurs during closing cycle.

TS18 — Opening torque switch interrupts control circuit if mechanical overload occurs during opening cycle.

NOTES

1. --- Open contact
2. █ Close contact
3. All limit switch trip points are fully adjustable.

LEGEND

- O** — Open contact
- C** — Close contact
- ⊕** — Opening coil
- ⊖** — Closing coil
- CPT** — Control Power Transformer
- +** — Mechanical interlock
- TH. OL** — Thermal overload contacts
- SS** — Selector switch (local-remote)
- PB1** — Open pushbutton
- PB2** — Stop pushbutton
- PB3** — Close pushbutton
- HTR1** — Space heater
- HTR2** — Space heater (Side mounted compt. only)
- POT** — Slidewire transmitter
- ⓧ** — Red indicating light
- Ⓞ** — Green indicating light
- RES** — Lamp Resistors

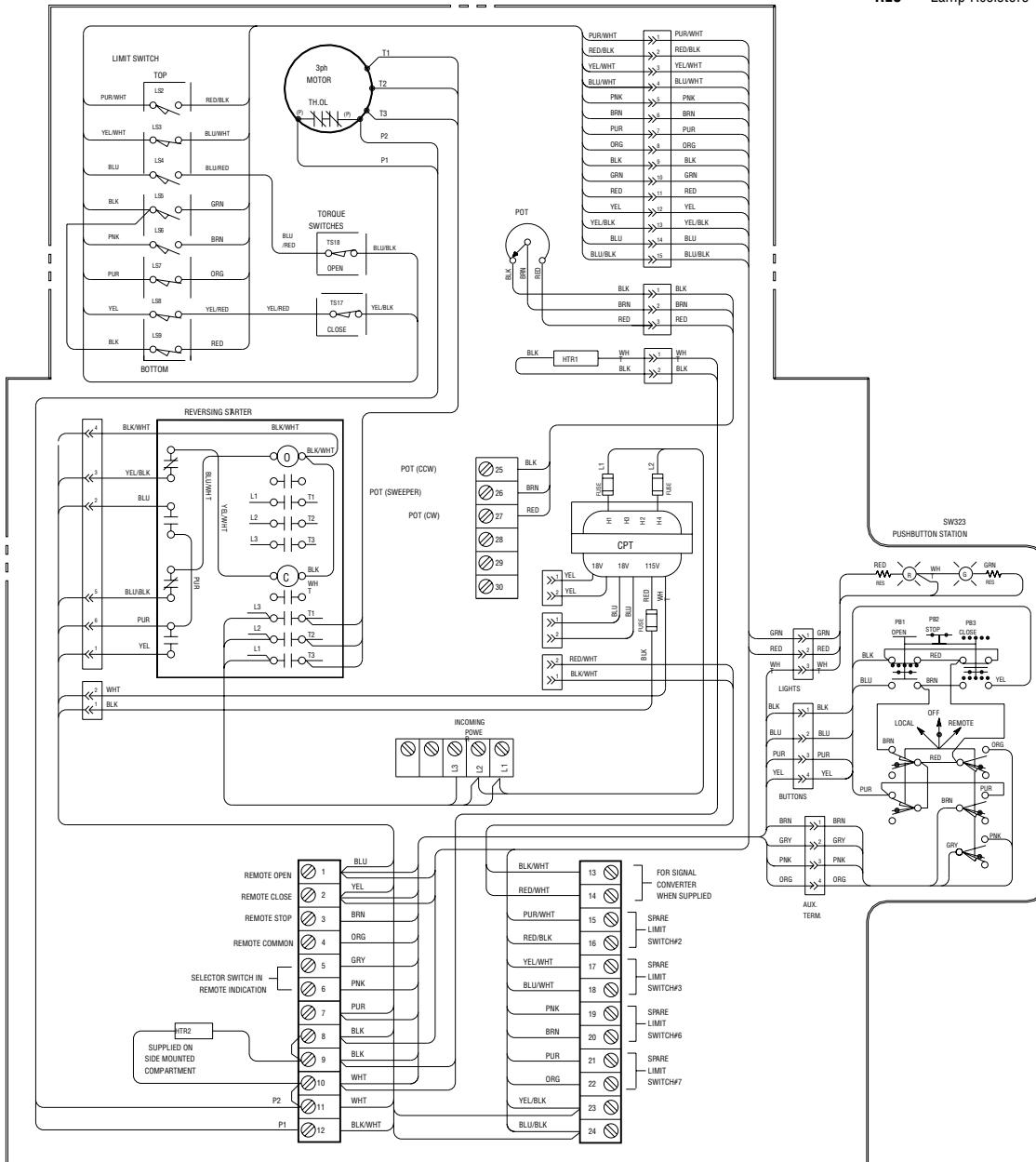
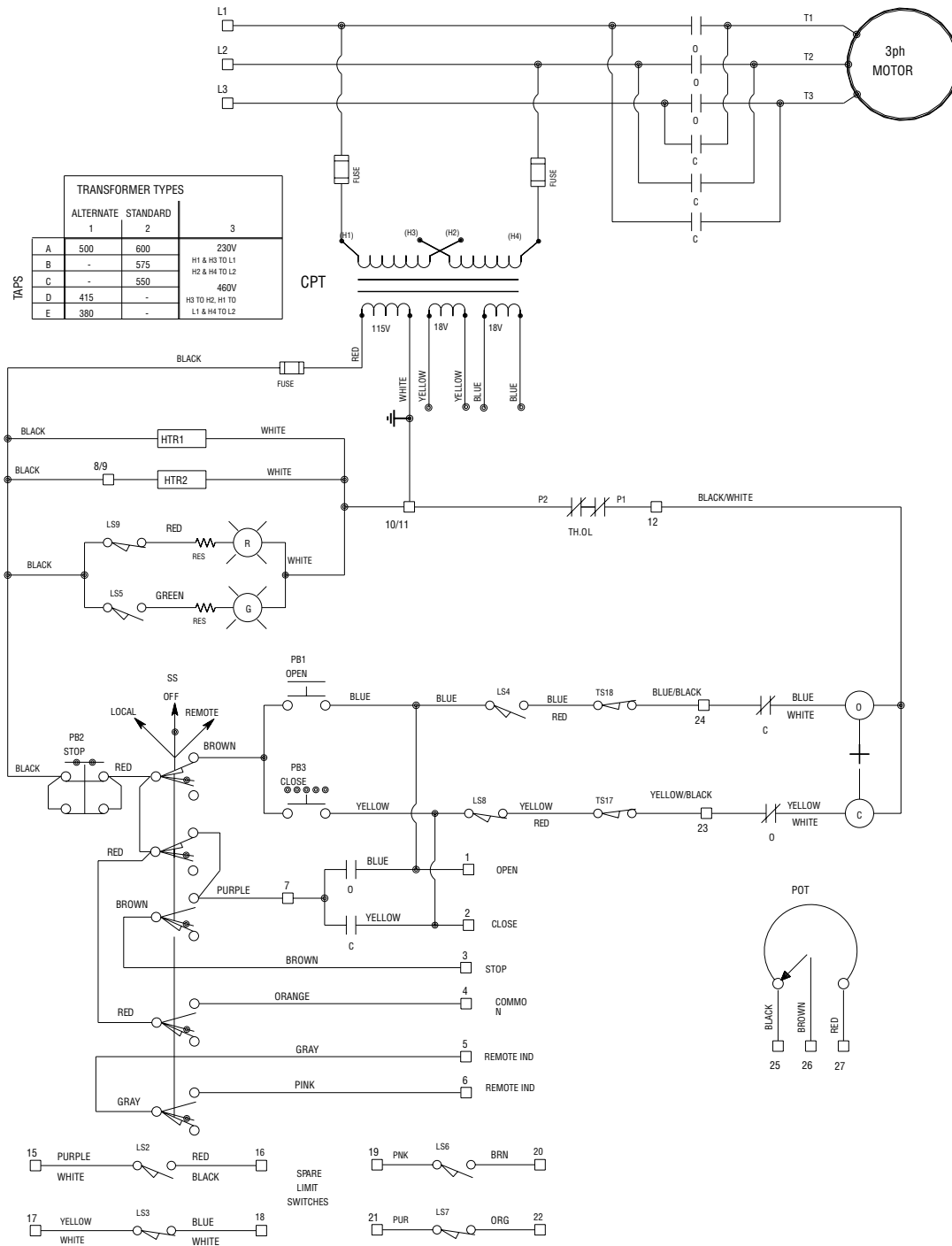

Figure 6.2 – Three-Phase with Control Package (continued)



6.2.2 Single-Phase Motor

NOTE: Your application may vary from the standard wiring configuration for the single-phase motor shown in Figures 6.3 and 6.4. Refer to the specific actuator wiring diagram for wiring configuration.

1. Using the Handwheel, move the valve to a midtravel position. Midtravel position allows electrical operation in the valve “safe” area and keeps the OPEN and CLOSED limit switches from tripping while testing motor direction.
2. Momentarily press the OPEN pushbutton to test motor direction. If the actuator moves toward CLOSED, immediately turn power OFF and proceed with the instructions that match your application. Permanent Split Capacitor single-phase motors can be connected for opposite rotation by interchanging the leads T1 and T2 coming from the motor to the terminal strip.

Figure 6.3 – Standard Actuator/Single-Phase

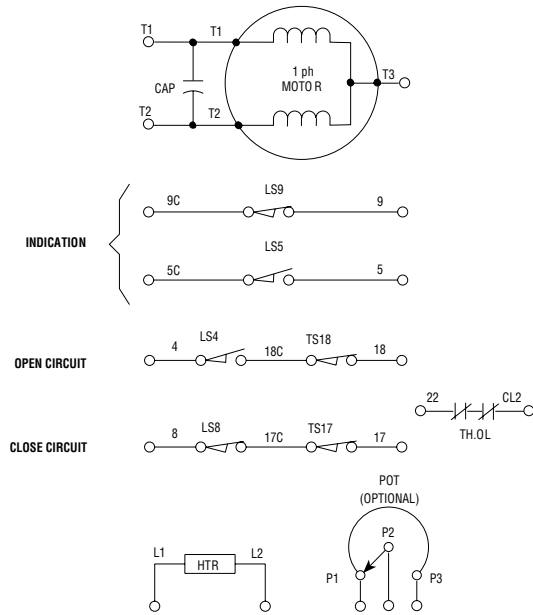

Valve shown in full open position

LIMIT SWITCH CONTACT	VALVE POSITION		FUNCTION
	FULL OPEN	FULL CLOSE	
4	—	█	OPEN LIMIT
5	—	█	INDICATION
8	█	—	CLOSED LIMIT
9	█	—	INDICATION

TS17 —Closing torque switch interrupts control circuit if mechanical overload occurs during closing cycle.

TS18 —Opening torque switch interrupts control circuit if mechanical overload occurs during opening cycle.

NOTES

1. - - - - Open contact
2. █ Close contact
3. All limit switch trip points are fully adjustable.

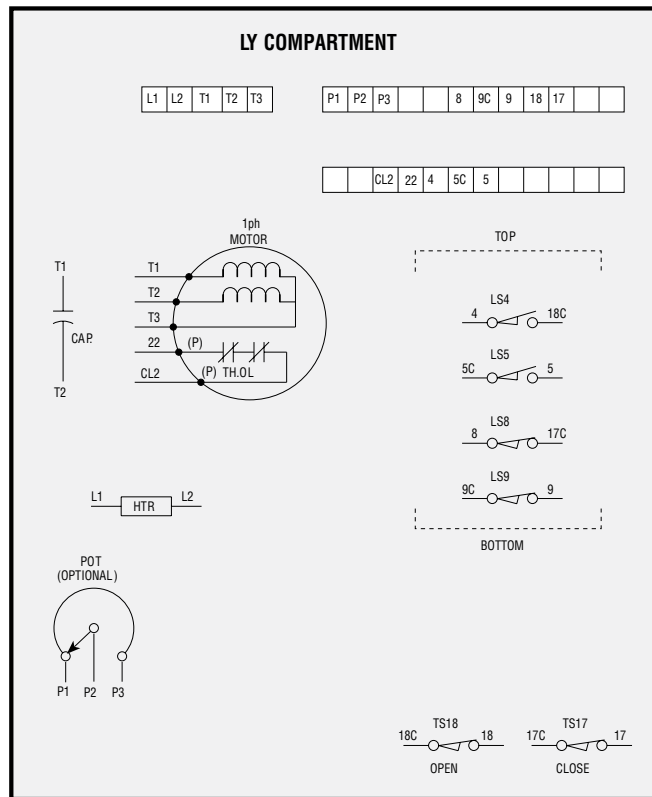

LEGEND

- HTR —Space heater (LY COMPT.)
- POT —Slidewire transmitter (optional)
(See certification sheet if supplied)
- TH. OL —Thermal overload (internal)

Note: Refer to certified data for construction purposes 16-476-1630-2C.

Figure 6.4 – Single-Phase with Control Package

Valve shown in full open position

LIMIT SWITCH CONTACT	VALVE POSITION		FUNCTION
	FULL OPEN	FULL CLOSE	
2	---	---	SPARE
3	---	---	SPARE
4	---	---	OPEN LIMIT
5	---	---	IND LIGHT
6	---	---	INDICATION
7	---	---	INDICATION
8	---	---	CLOSED LIMIT
9	---	---	IND LIGHT

TS17 — Closing torque switch interrupts control circuit if mechanical overload occurs during closing cycle.

TS18 — Opening torque switch interrupts control circuit if mechanical overload occurs during opening cycle.

NOTES

1. --- Open contact
2. ■ Close contact
3. All limit switch trip points are fully adjustable.

LEGEND

- O** — Open contact
- C** — Close contact
- ⓪** — Opening coil
- Ⓢ** — Closing coil
- CAP** — Motor capacitor
- +** — Mechanical interlock
- TH. OL** — Thermal overload contacts
- SS** — Selector switch (local-remote)
- PB1** — Open pushbutton
- PB2** — Stop pushbutton
- PB3** — Close pushbutton
- HTR1** — Space heater (LY Compt.)
- HTR2** — Space heater (Control Compt.)
- POT** — Slidewire transmitter (optional)
(See certification sheet if supplied.)
- J1** — Connector for Modutronic 20 units
- Red indicating light
- Green indicating light

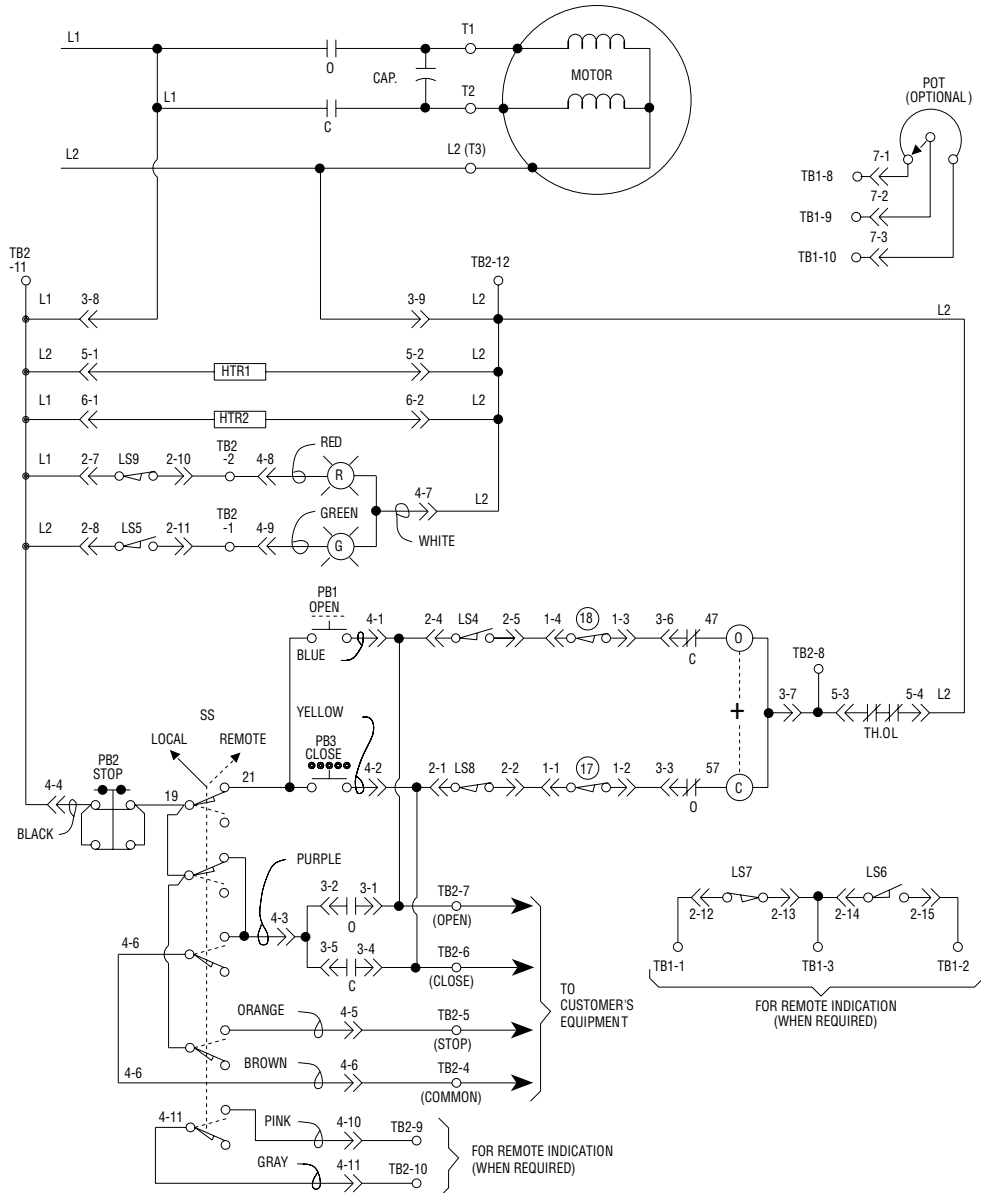
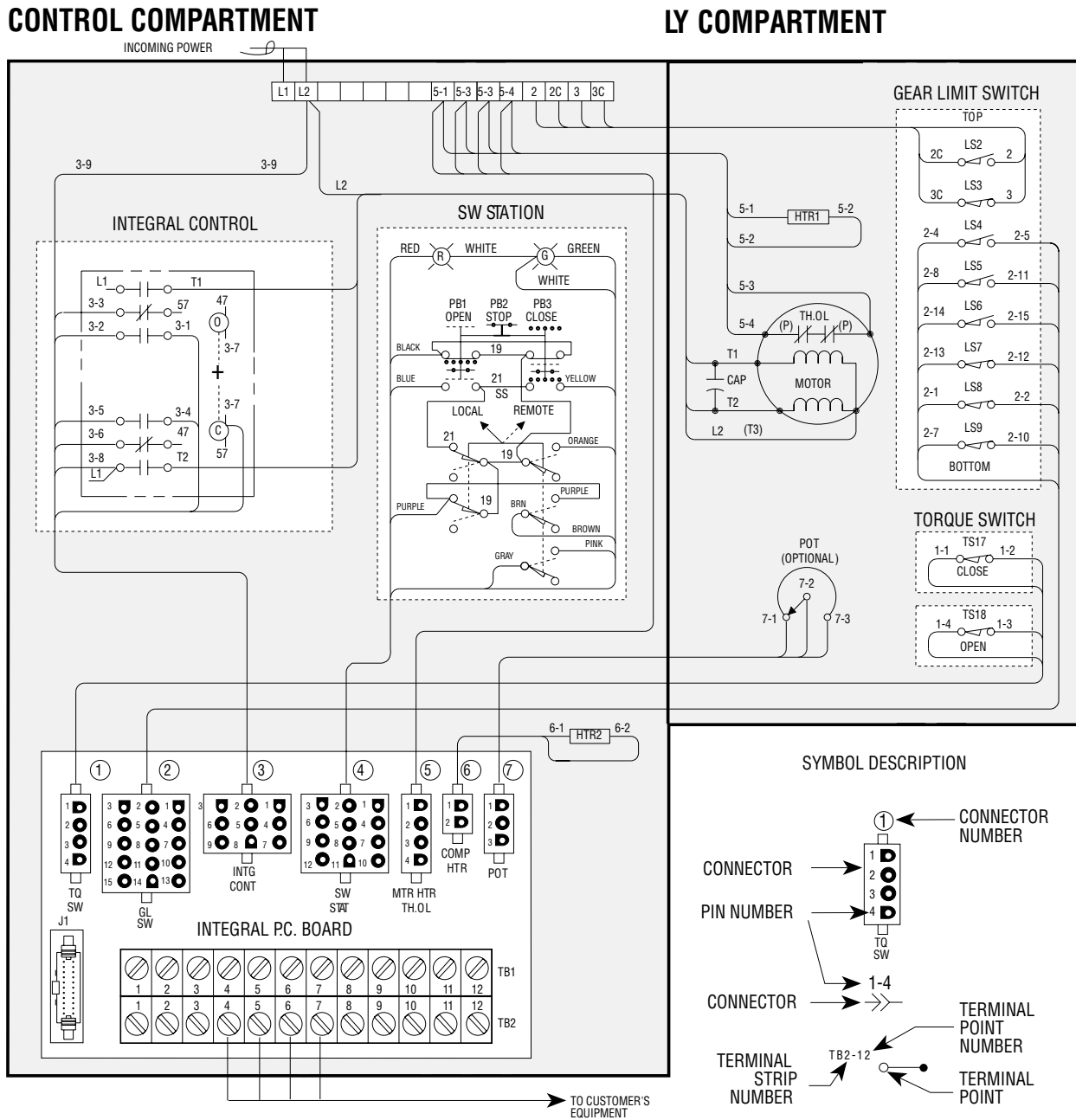

Figure 6.4 – Single-Phase with Control Package (continued)



Note: Refer to certified data for construction purposes 16-476-1633-3D.

6.2.3 DC Motor

NOTE: Your application may vary from the standard wiring configuration for the DC motor. Refer to the specific actuator wiring diagram for wiring configuration.

1. Using the Handwheel, move the valve to a midtravel position. Midtravel position allows electrical operation in the valve “safe” area and keeps the OPEN and CLOSED limit switches from tripping while testing motor direction.
2. Test motor direction by momentarily pressing the OPEN pushbutton:
 - a. If the actuator moves toward CLOSED, immediately turn all power OFF and reverse the motor leads A1 and A2 on the terminal strip.
 - b. If the actuator moves toward OPEN, the motor is wired properly for the application.

6.3 Electrical Startup

1. Confirm that the actuator has been correctly lubricated. This is particularly important if the actuator has been in long-term storage.
2. Ensure that the Torque Switch and Limit Switch have been properly set per Section 5.5, Torque Switch Settings and Section 5.8, Setting the Limit Switches respectively.
3. Engage MANUAL operation and hand-crank valve well away from the OPEN or CLOSED end-of-travel.
4. Turn power ON and push the OPEN button to electrically operate the actuator.
5. Verify output rotation:
 - If Motor rotation (phase) is correct, the valve will begin to open.
 - If the valve begins to CLOSE — STOP IMMEDIATELY.

Refer to Section 6.2, Verify Correct Motor Rotation (Phasing) and OPEN/CLOSE Pushbutton Operation to correct the motor rotation, if necessary.

6. If the actuator configuration has a control package, see the specific control package Instruction and Maintenance Manual for proper setup and calibration.

The actuator should operate correctly and will stop at the end-of-travel by the Torque and Limit Switch functions.

6.4 Manual Operation

- ⚠ **WARNING:** Do not manually operate actuator with devices other than installed Handwheel and Declutch Lever. Using additive force devices (cheater bars, wheel wrenches, pipe wrenches, or other devices of this nature) on the actuator handwheel or declutch lever may cause serious personal injury and/or damage to the actuator or valve.

Piece numbers refer to Figures 6.5, 6.6, and 6.7 for LY 1001 and Figure 6.8, 6.9, 6.10, and 6.11 for LY 2001/3001.

The LY actuator has a Handwheel for manual operation. The unit can be manually operated any time the motor is not energized.

1. To manually operate the actuator, push the Declutch Lever (piece #45) clockwise approximately 20° until it latches.
2. If the Declutch Lever will not turn 20° or it does not latch, DO NOT FORCE. Rotate the Handwheel (piece #41) slightly (in either direction) while continuing to push the Declutch Lever in the clockwise direction; the Declutch Lever will latch in place. When the Declutch Lever is latched in place, the Clutch (piece #13) is moved until its lugs engage with the lugs on the Handwheel Clutch (piece #16). This position is maintained indefinitely by the Declutch Fork Assembly (piece #46). When the motor is energized, a flat on the Input Worm Gear (piece #18) releases the Declutch Fork Assembly, pushing the Clutch into motor operation by the Declutch Return Spring (piece #47).

6.5 Motor Operation

- ⚠ **CAUTION:** Do not force the Declutch Lever into motor operation. Lever will automatically return to motor operation when the motor is energized.

Piece numbers refer to Figures 6.5, 6.6, and 6.7 for LY 1001, and Figures 6.8, 6.9, 6.10, and 6.11 for LY 2001/3001.

The Motor Pinion Gear (piece #54) turns the Worm Shaft Pinion Gear (piece #53), which is part of the Input Worm Shaft (piece #31). The Input Worm Shaft drives the Input Worm Gear (piece #18) that is lugged to the Clutch Sleeve (piece #13). The Input Worm Gear drives the Worm Shaft Assembly through the lugs and splines on the Clutch Sleeve. The Output Worm (piece #15) on the Worm Shaft Assembly turns the Drive Sleeve (piece #10). The Drive Sleeve accepts the Torque Nut (piece #32) that is bored and keyed to fit and turn the particular valve stem.

Figure 6.5 – LY 1001 Cover and Associated Parts

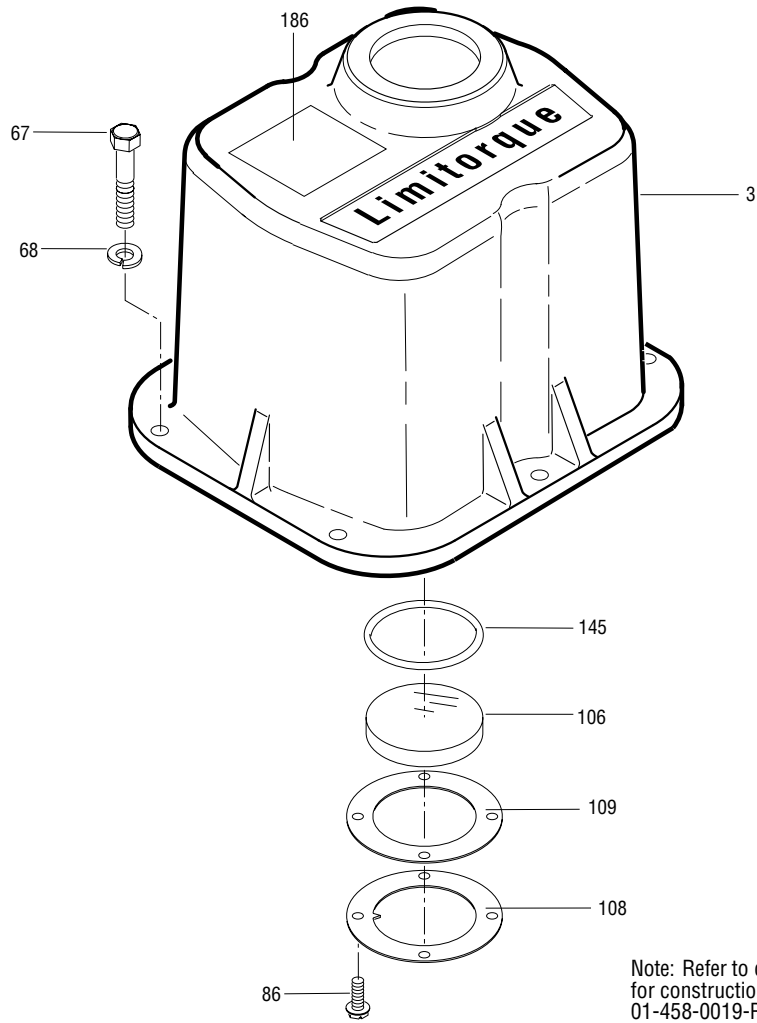
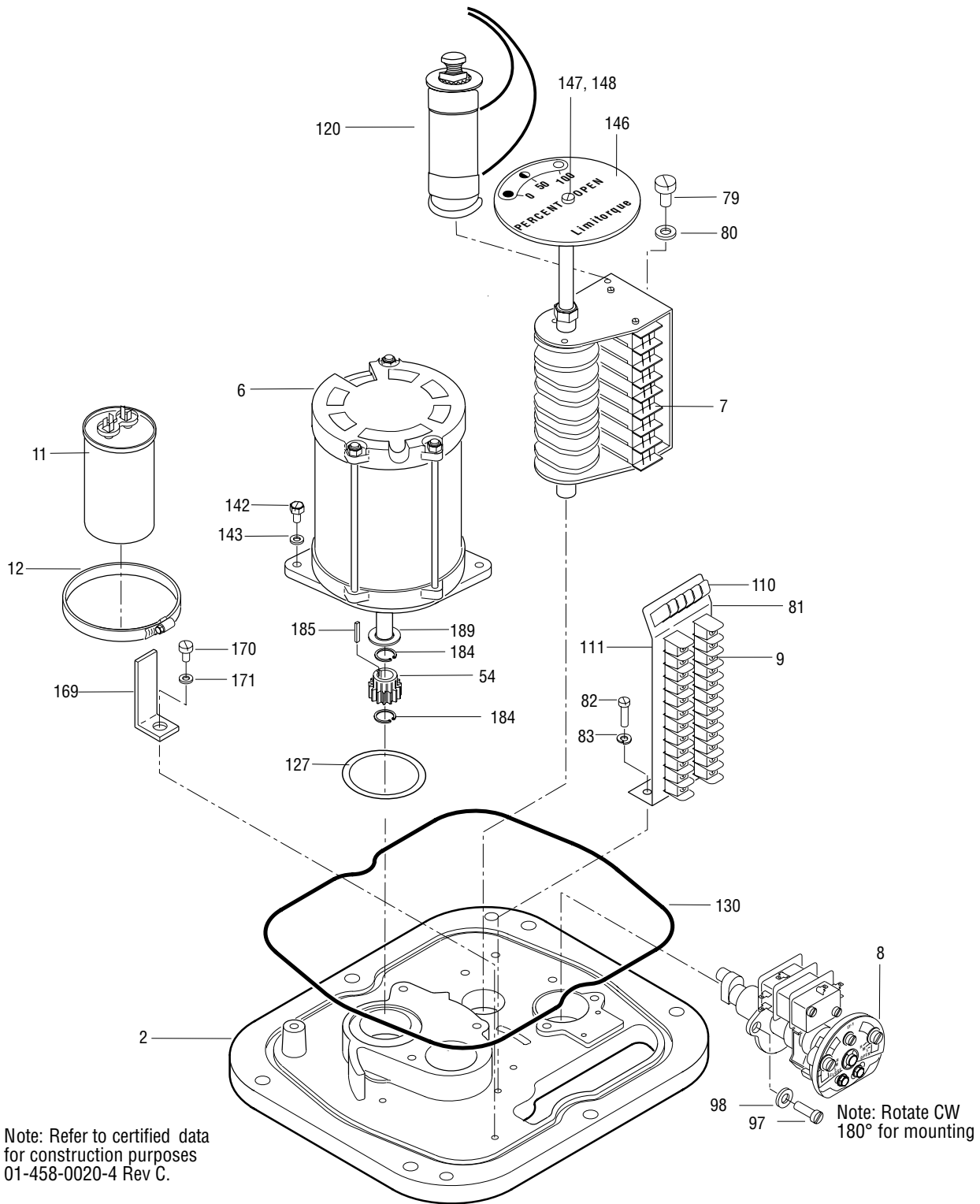
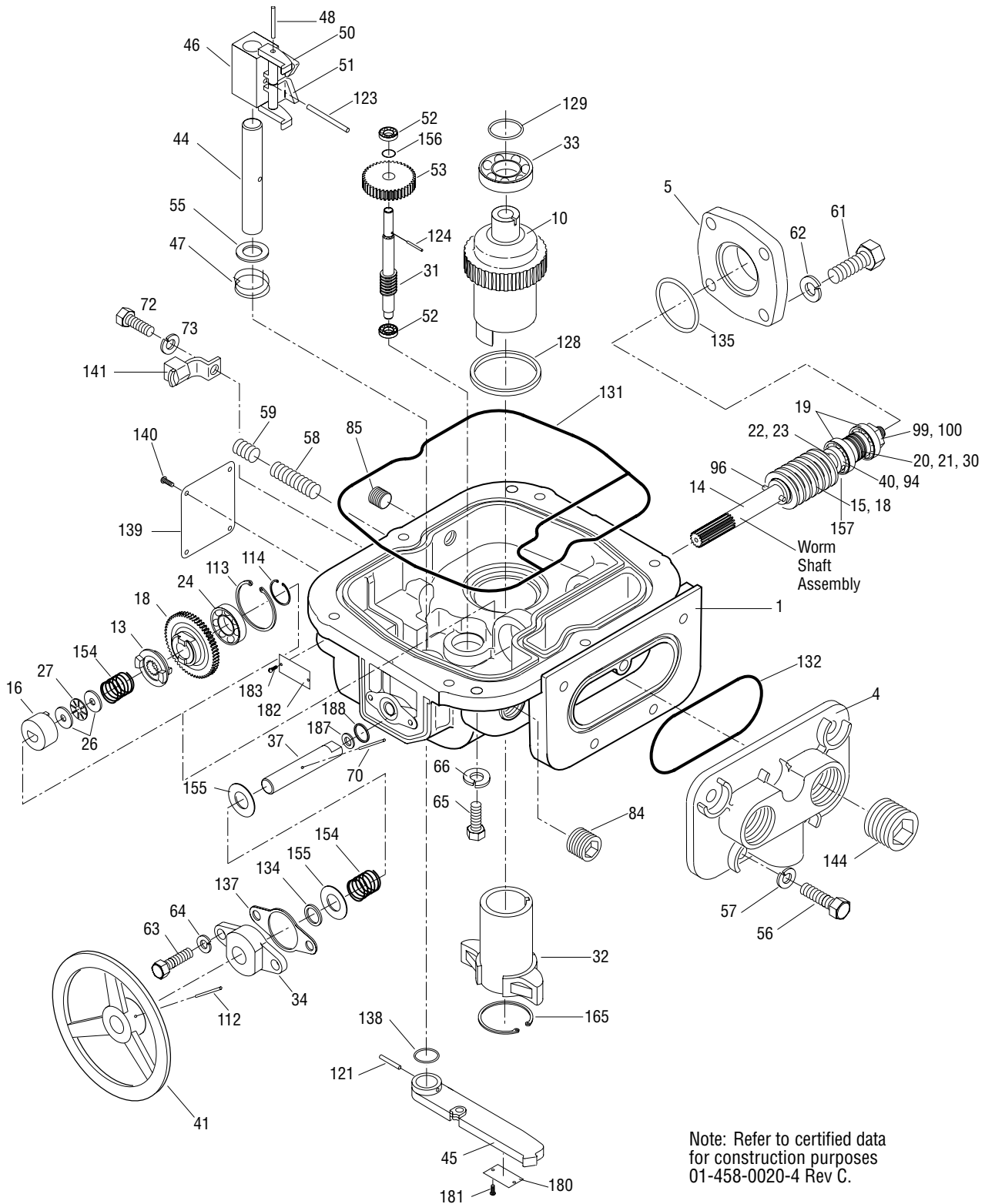

Figure 6.6 – LY 1001 Top Plate and Associated Parts



Note: Refer to certified data for construction purposes
01-458-0020-4 Rev C.

Figure 6.7 – LY 1001 Housing and Associated Parts



Note: Refer to certified data for construction purposes 01-458-0020-4 Rev C.

Figure 6.8 – LY 2001/3001 Cover and Associated Parts

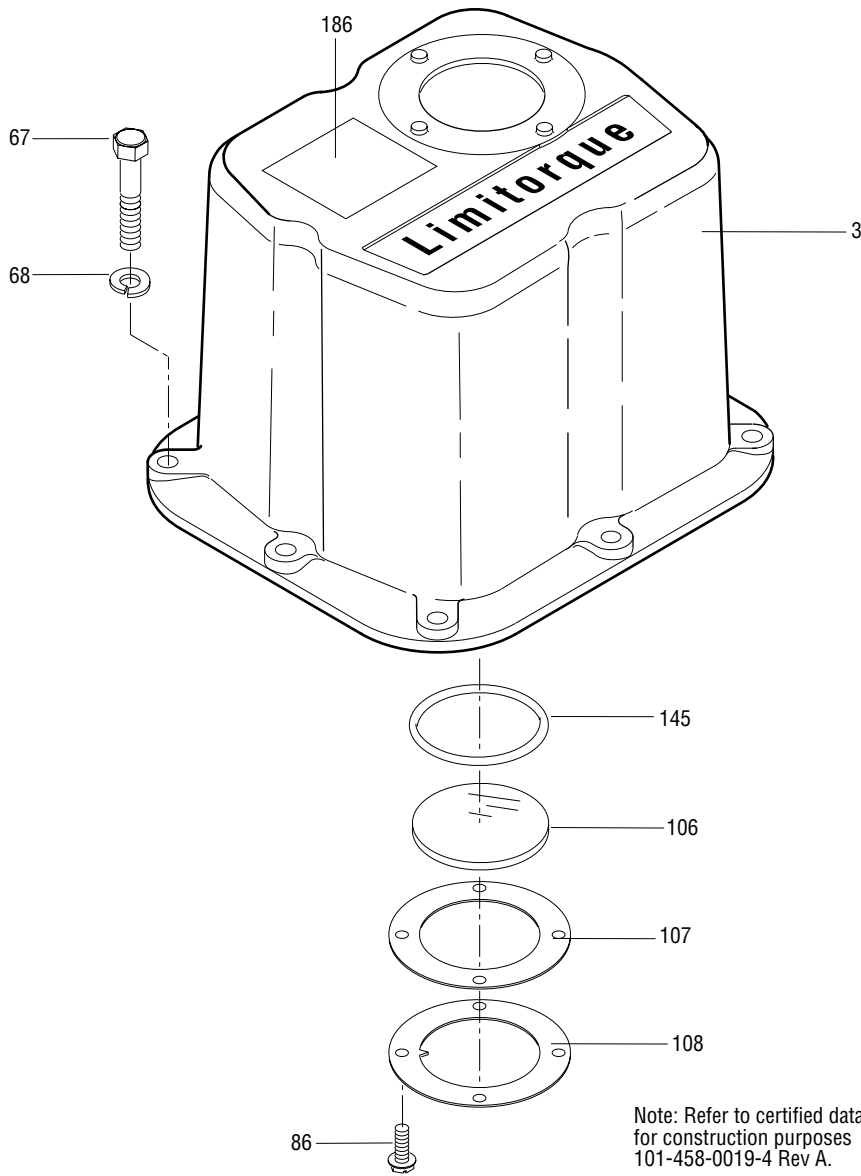
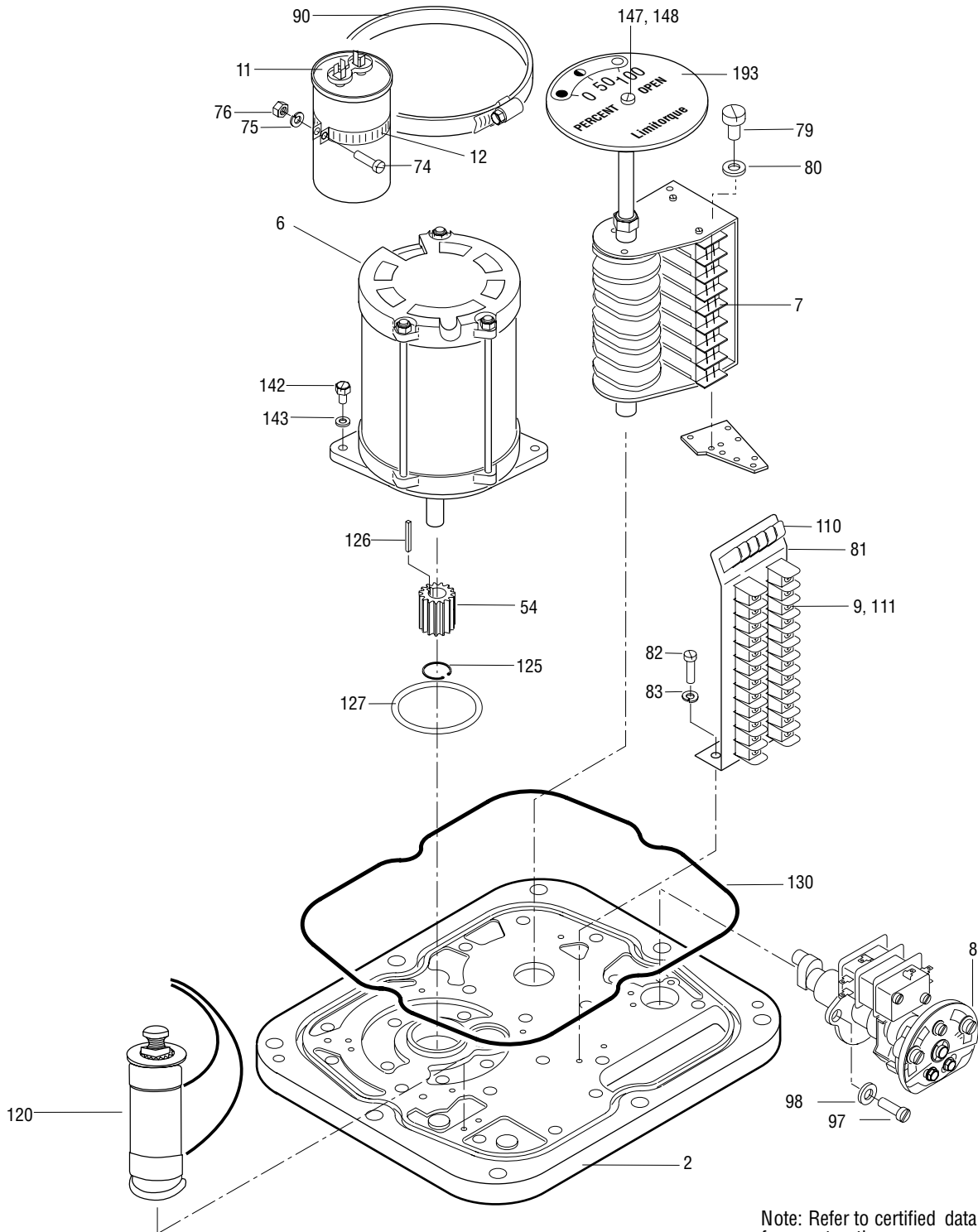
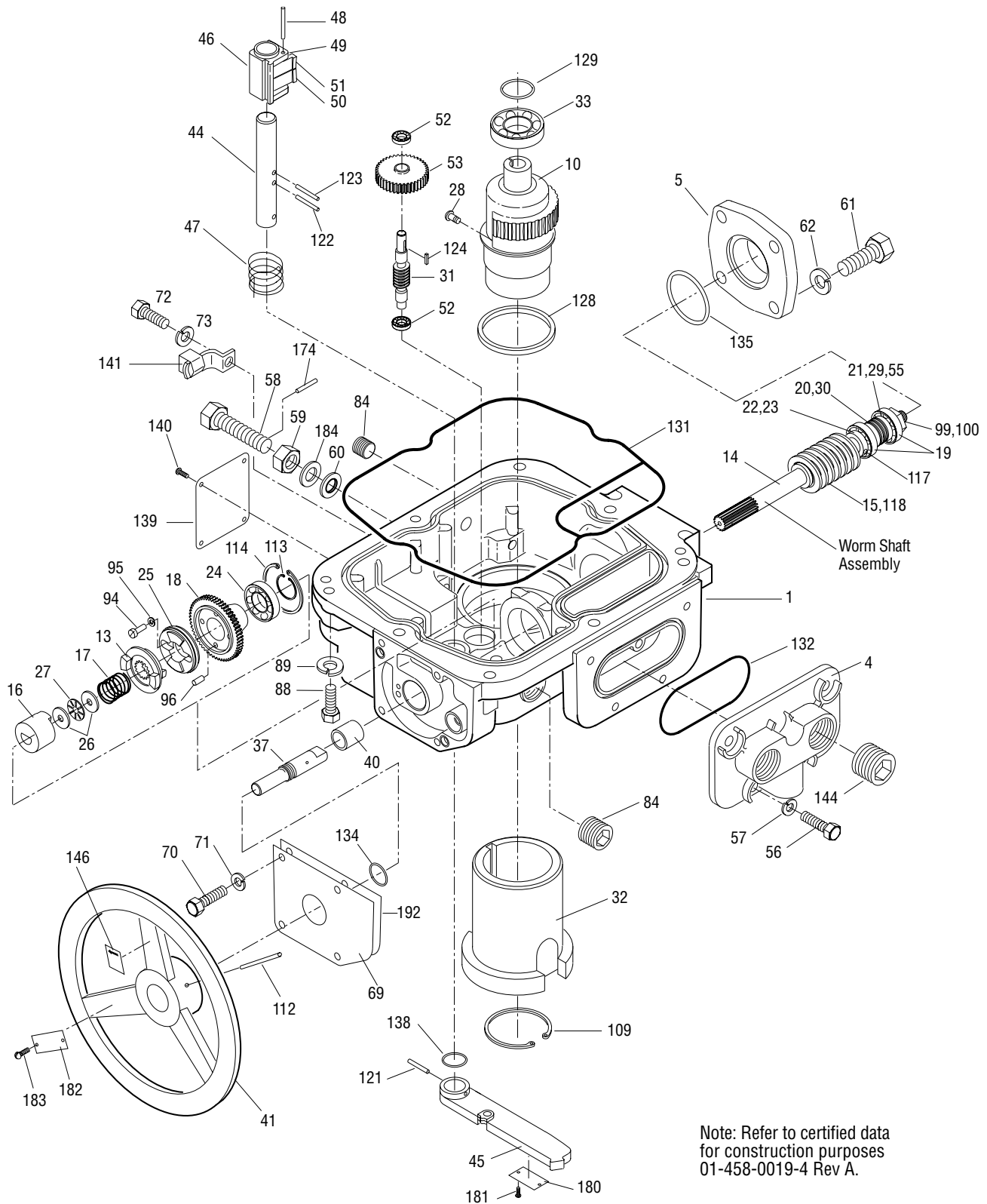

Figure 6.9 – LY 2001/3001 Top Plate and Associated Parts



Note: Refer to certified data for construction purposes 101-458-0019-4 Rev A.

Figure 6.10 – LY 2001/3001 Housing and Associated Parts



Note: Refer to certified data for construction purposes 01-458-0019-4 Rev A.

Figure 6.11 – LY 3001 Handwheel Assembly

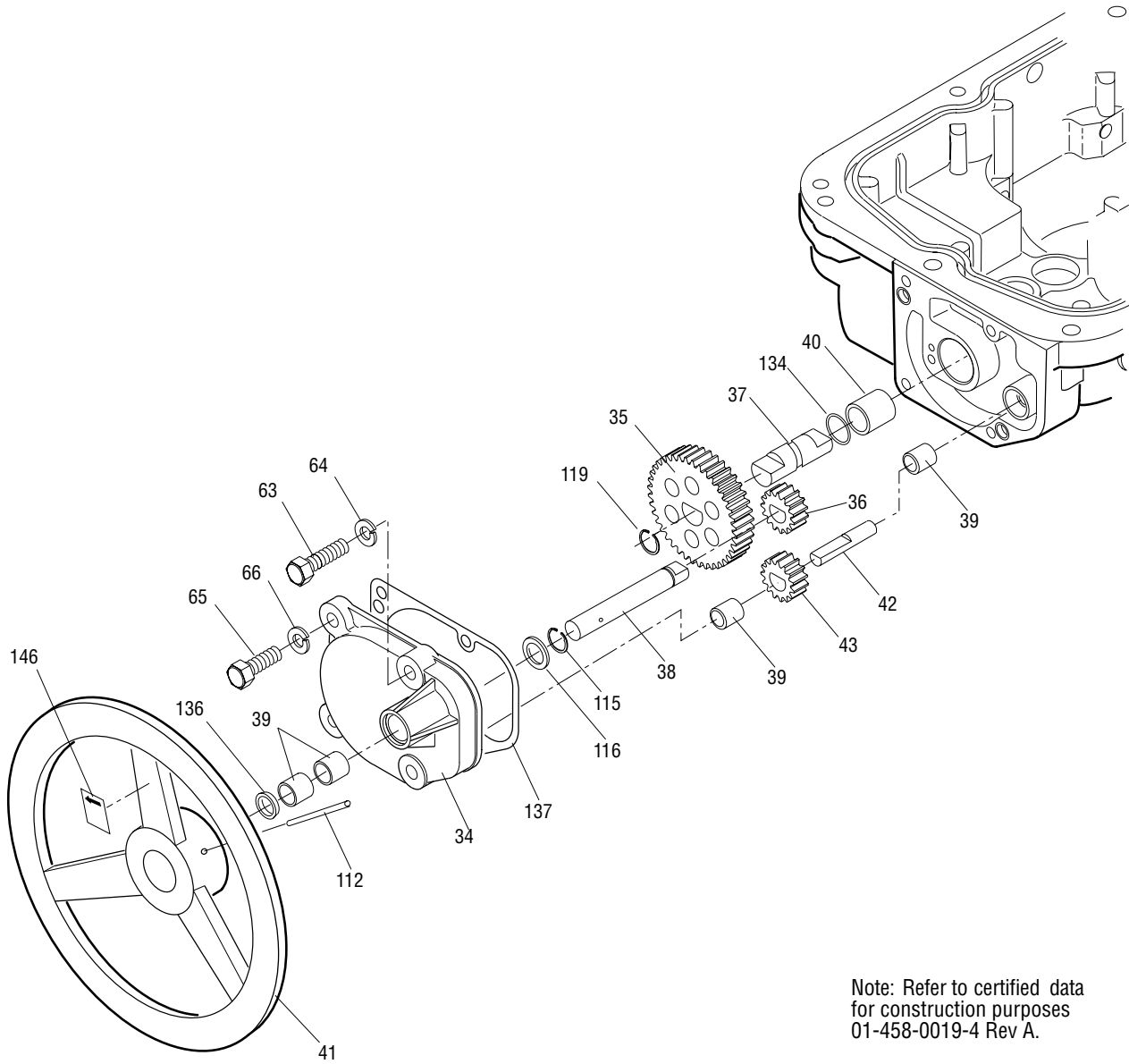

Note: Refer to certified data for construction purposes
01-458-0019-4 Rev A.

7 Maintenance

7.1 Lubrication

No seal can remain absolutely tight at all times. Therefore, it is not unusual to find a very small amount of weeping around shaft seals—especially during long periods of idleness such as storage. Using grease minimizes this condition as much as possible. If a small amount is weeping at startup, remove it with a clean cloth. Once the equipment is operating on a regular basis, the weeping should stop.

7.1.1 Lubrication Inspection

Inspect Limitorque LY series actuators for correct lubrication prior to operating—particularly following a long storage period.

Each application has its own effect on the actuator and the frequency of these inspections should be based on the application and the operating experience. The following lubrication inspection schedule is recommended until operating experience indicates otherwise.

For Gear Case, inspect lubrication every 18 months or 500 cycles, whichever occurs first.

During an inspection, consider the following:

- Quantity – LY operators are built to operate on the immersion principle. Ensure there is enough lubricant so that the Worm is totally immersed in grease regardless of the position.
- Quality – Inspect lubricant for dirt, water, or other foreign matter. If any one of these is found:
 1. Flush the actuator with a commercial degreaser/cleaner such as Exxon Varsol #18. This degreaser/cleaner is not corrosive and does not affect the seal materials.
 2. Repack the actuator with fresh lubricant, allowing room for grease thermal expansion.
- Consistency – Ensure the lubricant is fluid approximating a standard NLGI-0 grade consistency or less. Thinners such as Amoco WAYTAC #31 oil may be added provided the volume of thinner does not exceed 20% of the total lubricant.

7.1.2 Factory Lubricant

The LY actuator gear case is factory-lubricated with an NLGI Grade 0 lithium-base grease suitable for temperatures from -20°F (-29°C) to 250°F (121°C). For temperatures above or below this range, consult the factory.

7.2 Minimum Lubricant Qualities Required

The standard lubricants used by Flowserve have been proven to be extremely reliable over years of service. Flowserve does not recommend a particular lubricant substitute for the standard lubricants; however, Flowserve does require the following lubricant qualities as a minimum.

▲ **CAUTION:** Do not mix lubricants of a different base chemical. Mixing lubricant bases may cause lubricant properties to be ineffective.

The lubricant must:

- have “EP” properties.
- be suitable for the temperature range intended.
- be water and heat-resistant and non-separating.
- not create more than 8% swell in Buna N or Viton.
- not contain any grit, abrasive, or fillers.
- slump NLGI 0 or 00.
- not be corrosive to steel gears, ball, or roller bearings.
- have a dropping point above 316°F (158°C) for temperature ranges of -20°F (-9°C) to 250°F (121°C).

7.3 Disassembly and Reassembly

▲ **CAUTION:** Turn off all power services before attempting to perform service on the actuator. POTENTIAL HIGH-PRESSURE VESSEL. Before removing or disassembling your actuator, ensure that the valve or other actuated device is isolated and not under pressure.

7.3.1 LY 1001 Disassembly

Unless otherwise noted, piece numbers refer to the Illustrated Parts Breakdown of Figures 6.5, 6.6, and 6.7.

⚠ **WARNING:** HAZARDOUS VOLTAGE. Turn off all power before disassembling your LY actuator.

⚠ **WARNING:** POTENTIAL HIGH-PRESSURE VESSEL. Before disassembling your actuator, ensure that the valve or other actuated device is isolated and is not under pressure.

Remove Cover and Top Plate

1. Turn off all power to the actuator.
2. Remove the Control Cover (piece #3).

3. Disconnect all electrical leads from the Torque Switch (piece #8) and Limit Switch (piece #7). Make sure all wire leads are properly marked for reassembly.
4. Remove all external wires to the Terminal Strips (pieces #9 and 110).
5. If unit has an Integral Assembly, remove all wires from the Integral Assembly to the Terminal Strip (pieces #9 and 110).
6. Remove Screws/Lockwashers (pieces #77, 78, 79, and 80) that are holding the Limit Switch (piece #7) and Heater Assembly (piece #120). Remove the Limit Switch and Heater Assembly.
7. Remove two Screws (piece #97) and two Lockwashers (piece #98) that are holding the Torque Switch (piece #8). Remove the Torque Switch.
8. Remove two Screws (piece #65) and two Lockwashers (piece #66) to remove the Top Plate (piece #2).
9. Lift Top Plate (piece #2) off the LY Housing (piece #1). The Motor (piece #6) can be left attached to the Top Plate when the Top Plate is removed.

Remove Input Worm Motor Pinion Assembly

10. Remove Input Worm Motor Pinion Assembly (pieces #52, 156, 53, 124, and 31).

Remove Worm Shaft Assembly

11. Remove four Screws (piece #61) and four Lockwashers (piece #62) to remove Disc Spring Cap (piece #5).
12. Remove Disc Spring Cap (piece #5) and O-Ring (piece #135).
13. Rotate Worm Shaft Assembly CCW. The Worm Shaft Assembly should travel out of the Housing. Once it has reached the end-of-travel, pull the remaining Worm Shaft Assembly out; Clutch Sleeve (piece #13) will slip off the Worm Shaft Assembly. In the event that the Worm is stripped, the Worm Shaft Assembly will need to be completely replaced.

NOTE: If Light Spring Pack or Heavy Spring Pack replacement is necessary, contact your Limitorque authorized dealer or the Limitorque Service Department for a complete Worm Shaft Assembly replacement.

Remove Handwheel Assembly

14. Remove the Handwheel Clutch (piece #16), Compression Spring (piece #154), Clutch Sleeve (piece #13), Thrust Washer (piece #26 [two pieces]), and Thrust Bearing (piece #27).
15. Remove two Screws (piece #63) and two Lockwashers (piece #64) from the Handwheel Cap (piece #34).
16. Remove the Handwheel Assembly as one piece, (piece #41, 112, 34, 137, 134, 155 [two pieces], 154, 70, and 37).

Remove Drive Sleeve

17. Remove O-Ring (piece #129) and Bearing (piece #33) from the top of the Drive Sleeve (piece #10).
18. Remove the Drive Sleeve (piece #10).

Remove Declutch Assembly

19. Remove Roll Pin (piece #121) and remove Declutch Lever (piece #45).
20. Push the Declutch Assembly (piece #46, 123, 44, and 55 [two pieces]) up through the Housing and remove. Remove the Declutch Return Spring (piece #47).
21. Remove O-Ring (piece #138) from the Housing.

Remove Input Worm Gear

22. Remove the Retaining Drive Ring (piece #114).
23. Remove Input Worm Gear (piece #18) from the Ball Bearing (piece #24).

7.3.2 LY 1001 Reassembly

⚠ **WARNING: HAZARDOUS VOLTAGE.** Turn off all power before reassembling your LY actuator.

All piece numbers refer to Figures 6.5, 6.6, and 6.7.

Install Input Worm Gear

1. Install Input Worm Gear (piece #18).
2. Install External Retaining Drive Ring (piece #114) on Input Worm Gear.

Install Declutch Assembly

3. Install Declutch Return Spring (piece #47), making sure one end of Spring is secured behind the Rib of the actuator housing and the other end is secured behind the bottom Declutch Fork of the Declutch Fork Assembly.

Figure 7.1 – LY 1001 Declutch Return Spring Installation Position

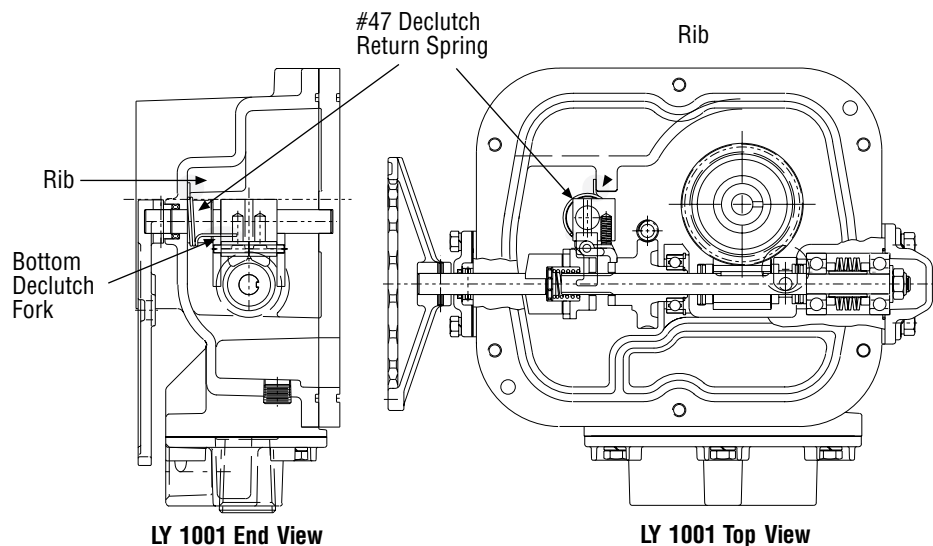

4. Install Declutch Assembly (piece #46, 123, 44, and 55).
5. Install O-Ring (piece #138) over Declutch Shaft (piece #44).
6. Install Declutch Lever (piece #45) and Roll Pin (piece #121).

Install Drive Sleeve

7. Install Drive Sleeve (piece #10).
8. Install Ball Bearing (piece #33) and O-Ring (piece #129) on the Drive Sleeve.

Install Worm Shaft Assembly

9. Install Worm Shaft Assembly.

NOTE: Push the Worm Shaft Assembly through to about ½" past the Input Worm Gear for installing the Clutch Sleeve (piece #13).

Install Handwheel Assembly

10. Install the Clutch Sleeve (piece #13), ensuring the Declutch Fork Assembly (piece #46) is between the Input Worm Gear (piece #18) and the Clutch Sleeve (piece #13).
11. Install Thrust Washer (piece #26), Thrust Bearing (piece #27), and second Thrust Washer (piece #26) into the Handwheel Clutch (piece #16).
12. Put a light coat of grease on the Thrust Bearing. Install Spring (piece #154) into the Handwheel Clutch.
13. Install Handwheel Clutch Assembly (pieces #16, 154, 26 [two pieces], and 27) into the Housing. Push remaining Worm Shaft Assembly into the Handwheel Clutch of the Handwheel Clutch Assembly.
14. Install O-Ring (piece #135) over the Worm Shaft Assembly Bearing.
15. Install Disc Spring Cap (piece #5) and Hardware (pieces #61 and 62).
16. Install Handwheel Cap Gasket (piece #137) and Handwheel Assembly (pieces #41, 112, 34, 137, 134, 155 [two pieces], 154, 70, and 37).
17. Install Hex Head Cap Screw and Lockwasher (pieces #63 and 64).

Install Input Worm Motor Pinion Assembly

18. Install Input Worm Motor Pinion Assembly (pieces #52, 156, 53, 124, and 31) into the Housing.
19. Install Housing Seal (O-Ring) (pieces #131).

Grease Unit

20. Grease unit with the properly recommended grease. (See Section 7.1, Lubrication.)

Install Top Plate

21. Install Top Plate (piece #2) and Hardware (pieces #65 and 66).

NOTE: If Top Plate will not fit properly, check Ball Bearing (piece #33) and Declutch Shaft (piece #44) for proper alignment into Top Plate molding.

Install Torque Switch Assembly, Motor Assembly, and Limit Assembly

22. Install Torque Switch Assembly (piece #8) with Gasket and Hardware (piece #98 and 97).
23. Install Limit Switch Assembly (piece #7) and Heater Assembly (piece #120) with Hardware (piece #77, 78, 79, and 80).
24. Reconnect Limit Switch, Torque Switch, and Terminal Strip. (See the wiring diagram included with the actuator for proper wiring configuration.)

Install Control Cover

NOTE: Before installing the Control Cover, reset the Limit Switches and Mechanical Stops. Recheck motor for proper rotation.

25. Install Cover Seal O-Ring (piece #130).
26. Install Control Cover (piece #3) with Hardware (piece #67 and 68).

7.3.3 LY 2001/3001 Disassembly

- ⚠ **WARNING:** HAZARDOUS VOLTAGE. Turn off all power before disassembling your LY actuator.
- ⚠ **WARNING:** POTENTIAL HIGH-PRESSURE VESSEL. Before disassembling your actuator, ensure that the valve or other actuated device is isolated and is not under pressure.

Piece numbers refer to Figures 6.8, 6.9, 6.10, and 6.11.

Remove Cover and Top Plate

1. Shut off all power to the actuator.
2. Remove the Control Cover (piece #3).
3. Disconnect all electrical leads from the Torque Switch (piece #8) and Limit Switch (piece #7). Make sure all wire leads are properly marked for reassembly.
4. Remove all external wires to the Terminal Strips (piece #9, 110, and 111).
5. If unit has an Integral Assembly, remove all wires from the Integral Assembly to the Terminal Strip (piece #9, 110, and 111).
6. Remove Screws/Lockwashers (piece #79 and 80) that are holding the Limit Switch (piece #7). Remove the Limit Switch.
7. Remove two Screws (piece #97) and two Lockwashers (piece #98) that are holding the Torque Switch (piece #8). Remove the Torque Switch.
8. Remove two Screws (piece #88) and two Lockwashers (piece #89) to remove the Top Plate (piece #2).

9. Lift Top Plate (piece #2) off the LY Housing (piece #1). The Motor (piece #6) can be left attached to the Top Plate when the Top Plate is removed.

Remove Input Worm Motor Pinion Assembly

10. Remove Input Worm Motor Pinion Assembly (piece #52, 53, 124, and 31).

Remove Worm Shaft Assembly

11. Remove four Screws (piece #61) and four Lockwashers (piece #62) to remove Bearing Cap (piece #5).
12. Remove Bearing Cap (piece #5) and O-Ring (piece #135).
13. Rotate Worm Shaft Assembly counterclockwise. The Worm Shaft Assembly should travel out of the Housing. Once it has reached the end-of-travel, pull the remaining Worm Shaft Assembly out; Clutch Sleeve (piece #13) will slip off the Worm Shaft Assembly. In the event that the Worm is stripped, the Worm Shaft Assembly will need to be completely replaced.

NOTE: If Light Spring Pack or Heavy Spring Pack replacement is necessary, contact your Limitorque authorized dealer or the Limitorque Service Department for a complete Worm Shaft Assembly replacement.

Remove Handwheel Assembly (LY 2001)

14. Remove the Handwheel Clutch (piece #16), Compression Spring (piece #17), Clutch Sleeve (piece #13), Thrust Washer (piece #26 [two pieces]), and Thrust Bearing (piece #27).
15. Remove four Screws (piece #70) and four Lockwashers (piece #71) from the Handwheel Cap Plate (piece #69).
16. Remove the Handwheel Assembly as one piece (pieces #146, 41, 112, 69, 192, 134, and 37).
17. Go to Step 19.

Remove Handwheel Assembly (LY 3001)

14. Remove the Handwheel Clutch (piece #16), Compression Spring (piece #17), Clutch Sleeve (piece #13) and Thrust Washer (piece #26 [two pieces]), and Thrust Bearing (piece #27).
15. Remove Screws (pieces #63 and 65) and Lockwashers (piece #64 and 66) from the Spur Gear Cover (piece #34) of the Handwheel Assembly.
16. Remove the Handwheel Assembly as one piece (pieces #146, 41, 112, 136, 39 [two pieces], 34, 137, 116, 115, 38, and 36).
17. Remove the Handwheel Pinion and Idler (piece #43) and Idler Shaft (piece #42).
18. Remove the Handwheel Gear Assembly (pieces #119, 35, and 37).

Remove Drive Sleeve

19. Remove the Roll Pins (piece #174) located in the end of the Mechanical Stop Screws (piece #58).
20. Remove the Mechanical Stop Screws (piece #58), Locking Nut (piece #59), Thread-Seal (piece #60), and Retaining Washer (piece #184).

21. Remove O-Ring (piece #129) and Bearing (piece #33) from the top of the Drive Sleeve (piece #10).
22. Remove the Drive Sleeve (piece #10).

Remove Declutch Assembly

23. Remove Roll Pin (piece #121) and remove Declutch Lever (piece #45).
24. Push the Declutch Assembly (pieces #46, 48, 123, 122, and 44) up through the Housing and remove. Then remove Declutch Return Spring (piece #47).
25. Remove O-Ring (piece #138) from the Housing.

Remove Input Worm Gear

26. Remove the Retaining Drive Ring (piece #113).
27. Remove Input Worm Gear (piece #18) and Lug Adapter (piece #25) as an assembly from the Ball Bearing (piece #24).

7.3.4 LY 2001/3001 Reassembly

⚠ **WARNING:** HAZARDOUS VOLTAGE. Turn off all power before assembling the LY actuator.

Piece numbers refer to Figures 6.8, 6.9, 6.10, and 6.11.

Install Input Worm Gear

1. Install Input Worm Gear (piece #18).
2. Install External Retaining Drive Ring (piece #113) on Input Worm Gear.

Install Declutch Assembly

3. Install Declutch Return Spring (piece #47), making sure one end of Spring is secured in the Spring Seat Hole of the actuator housing and the other end is secured around the Roll Pin (piece #122) on the Declutch Fork Assembly.

Figure 7.2 – LY 2001/3001 Declutch Return Spring Installation Position

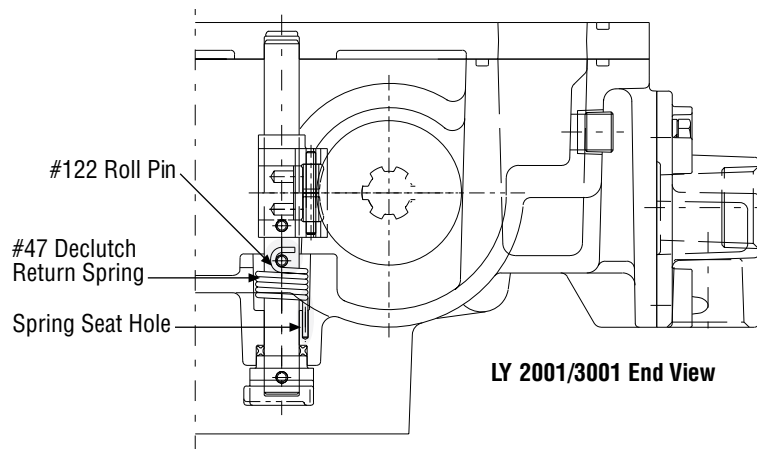

4. Install Declutch Assembly (piece #46, 48, 123, 122, and 44).
5. Install O-Ring (piece #138) over Declutch Shaft (piece #44).
6. Install Declutch Lever (piece #45) and Roll Pin (piece #121).

Install Drive Sleeve

7. Install Drive Sleeve (piece #10).
8. Install Bearing (piece #33) and O-Ring (piece #129) on the Drive Sleeve.
9. Install the Mechanical Stop Screws (piece #58), Locking Nut (piece #59), Thread-Seal (piece #60), and Retaining Washer (piece #184).
10. Install the Roll Pins (piece #174) located in the end of the Mechanical Stop Screws (piece #58).

Install Worm Shaft Assembly

11. Install Worm Shaft Assembly. Push the Worm Shaft Assembly through to about ½" past the Input Worm Gear. This allows installation of the Clutch Sleeve (piece #13).

Install Handwheel Assembly

12. Install the Clutch Sleeve (piece #13), ensuring the Declutch Fork Assembly (piece #46) is between the Input Worm Gear (piece #18) and the Clutch Sleeve (piece #13).
13. Install Thrust Washer (piece #26), Thrust Bearing (piece #27) and second Thrust Washer (piece #26) into the Handwheel Clutch (piece #16).
14. Put a light coat of grease on the Thrust Bearing. Install Spring (piece #17) into the Handwheel Clutch.
15. Install Handwheel Clutch Assembly (pieces #16, 17, 26 [two pieces], and 27) into the Housing. Push remaining Worm Shaft Assembly into the Handwheel Clutch of the Handwheel Clutch Assembly.
16. Install O-Ring (piece #135) over the Worm Shaft Assembly Bearing.
17. Install Bearing Cap (piece #5) and Hardware (pieces #61 and 62).

LY 2001 Handwheel Assembly

18. Install Handwheel Assembly (pieces #146, 41, 112, 69, 192, 134, and 37).
19. Install Hardware (pieces #70 and 71).
20. Go to Step 22.

LY 3001 Handwheel Assembly

18. Install the Handwheel Gear Assembly (pieces #119, 35, and 37).
19. Install the Handwheel Pinion and Idler (piece #43) and Idler Shaft (piece #42).
20. Install the Handwheel Assembly (pieces #146, 41, 112, 136, 39, 34, 137, 116, 115, 38, and 36).
21. Install Screws (pieces #63 and 65) and Lockwashers (pieces #64 and 66) to secure the Handwheel Assembly onto the housing.

Install Input Worm Motor Pinion Assembly

22. Install Input Worm Motor Pinion Assembly (piece #52, 53, 124, and 31) into the Housing.
23. Install Housing Seal (O-Ring) (piece #131).

Grease Unit

24. Grease unit with the properly recommended grease. (See Section 7.1, Lubrication.)

Install Top Plate

25. Install Top Plate (piece #2) and Hardware (piece #88 and 89).

NOTE: If Top Plate will not fit properly, check Bearing (piece #33) and Declutch Shaft (piece #44) for proper alignment into Top Plate molding.

Install Torque Switch Assembly, Motor Assembly, and Limit Assembly

26. Install Torque Switch Assembly with Gasket (piece #8) and Hardware (piece #97 and 98).
27. Install Limit Switch (piece #7) with Hardware (piece #79 and 80).
28. Reconnect Limit Switch, Torque Switch, and Terminal Strip. Refer to the actuator wiring diagram for proper wiring configuration.

Install Control Cover

NOTE: Before installing the Control Cover, reset the Limit Switches and Mechanical Stops. Recheck motor for proper rotation.

29. Install Cover O-Ring (piece #130).
30. Install Control Cover (piece #3) with Hardware (piece #67 and 68).

7.4 Troubleshooting

⚠ WARNING: Be aware of electrical hazards within the actuator and high-pressure hazards of the attached valve or other actuated device when installing or performing maintenance on the LY actuator.

Symptom	Possible Cause	Corrective Action
Unit will not operate electrically	No power to unit	<p>a. Verify power supply is electrically correct and present at actuator.</p> <p>b. Verify power leads are connected in accordance with the applicable wiring diagram.</p> <p>c. Inspect for blown fuse, tripped circuit breaker or overload or open disconnect switch.</p>
	Loose or incorrect wiring	Check wiring for proper wiring connection in accordance with the applicable wiring diagram. Check also for tight connections.
	Limit Switches not set or incorrectly set	Check Limit Switch development incorrectly set for agreement with the applicable wiring diagram. If not set properly, follow instructions in Section 5.7, Limit Switch and Mechanical Stop Settings.
	Foreign material on switch contacts preventing good electrical contact	Check continuity of microswitch with an ohmmeter.
Motor runs, but no output from unit	Actuator not coupled properly to output	Inspect Torque Nut and Valve Shaft to verify key is in place and properly staked.
	Worm gear worn out	Remove Worm Shaft Assembly in accordance with Section 7.3.1, Disassemble Unit LY 1001 or Section 7.3.3, Disassemble Unit LY 2001/3001 as applicable. Inspect worm gear for unusual wear. If excessive wear has occurred, replace the Worm Shaft Assembly.
	Torque Nut disengaged from Drive Sleeve	Verify Torque Nut properly installed in accordance with Section 5.4, Installation (continued) Overview Step No. 1.
Motor runs, but no output from unit	Damaged gearing	Disassemble actuator in accordance with Section 7.3.1, Disassemble Unit LY 1001 or Section 7.3.3, Disassemble Unit LY 2001/3001 as applicable. Inspect gearing for rough or damaged spots. Replace as required. Most often, damaged spots are seen in motor gear set.

Symptom	Possible Cause	Corrective Action
Unit operation is noisy	Inadequate lubrication (poor quality or not enough)	Inspect quality and quantity of lubrication in accordance with Section 7.1, Lubrication.
	Gearing misaligned	Inspect gearing for uneven wear pattern and replace gearing as needed. Most wear is seen in the motor gear set.
	Worn or damaged bearings	Disassemble unit and replace worn bearings, seals, and lubricant.
Fuse blown	Incorrect fuse size	Verify fuses are sized correctly.
	Pinched wire	Inspect control compartment to ensure Control Cover is not pinching or making contact with wiring when installed.
	Power surges	Investigate control circuit for surges.
Premature Torque Switch trip	Torque Switch setting too low	Increase Torque Switch setting as Switch trip required, up to but not exceeding maximum setting established by the Torque Switch Limiter Plate.
	Valve packing too tight	Inspect valve packing for excessive tightness. Repair valve by replacing packing as required. Refer to your valve manufacturer for specific instructions.
	Unit is not properly aligned with valve	Take bolts off between the unit and the valve. Check for proper unit alignment.
	Valve needs lubrication	Check valve lubrication using grease fitting on bottom of valve.
Torque Switch fails to stop actuator	Output rotation not in agreement with unit wiring	Consult Flowserve to verify design rotation. If actual rotation is opposite to design rotation, the Torque Switch needs to have contact wiring reversed.
	Inadequate voltage going to unit	Check incoming voltage supply.
Reversing Starter failure	Starter undersized	Verify starter is sized correctly for application. Consult factory to evaluate.
	Excessive cycling (too frequent operation)	Review application to determine number of starts per hour and review with factory if more than 100 per hour.
Excessive current draw	Valve running loads higher than expected	Inspect valve for possible causes of high running load. In particular, check for excessive tightness of valve packing and for proper lubrication of valve. Consult Flowserve for review of application.

Symptom	Possible Cause	Corrective Action
Motor overload tripping	Excessive current draw	Inspect valve for possible causes of high running load. In particular, check for excessive tightness of valve packing and for proper lubrication of valve. Consult Flowserve for review of application.
	Incorrect overloads	Verify proper overloads selected for motor rating.
Excessive gear wear	Excessive loads	Verify actual loads are in accordance with both start and run capabilities of your actuator.
	Inadequate lubrication	Inspect quality and quantity of lubrication in accordance with Section 7.1, Lubrication.
	Improper alignment	Inspect worn gears for evidence of uneven wear pattern.
Excessive torque required to turn handwheel	Valve running loads higher than expected	Inspect valve for possible cause of high running loads. In particular, check for excessive tightness of valve packing, proper lubrication of valve stem, bent or damaged valve, tight Stem/Torque Nut fit, worm, or damaged Stem Nut.
	Unit is not properly aligned with valve	Take bolts off between the unit and the valve and check for proper unit alignment.
Oil leaking from unit	Infrequent operation of actuator resulting in grease separation	Institute periodic operation of unit into a maintenance program to keep grease mixed. If not possible, schedule more frequent lubrication to ensure adequate lubrication of gearbox.
	Damaged or worn seals	Replace seals.
Valve is closed, but flow is not cut off	Valve mechanical stops not set correctly	<p>a. Do not set Torque Switch flow is not cut off not set correctly higher than maximum setting defined by Torque Limiter Plate. Inspect valve seat and repair as required.</p> <p>b. Check setting of Closed Mechanical Stop.</p>

⚠ **CAUTION:** Most quarter-turn valves are position-seated, not torque-seated. Applying additional torque to the hand-wheel and/or repeated electrical bumping at the full closed position may damage the valve and/or the actuator.

8 Parts List

Table 8.1 – LY 1001 Parts List (Refer to Figures 6.5, 6.6 and 6.7)

Piece #	Description	Qty
1	LY 1001 Housing	1
2	Top Plate	1
3	Control Cover	1
4	Conduit Adapter	1
5	Disc Spring Cap	1
6	Motor	1
7	Limit Switch Assembly	4
8	Torque Switch Assembly	1
9	Terminal Strip	2
10	Drive Sleeve	1
11	Capacitor	Varies
12	Capacitor Clamp	1
13	Clutch Sleeve	1
14	Worm Shaft*	1
15	Worm*	1
16	Handwheel Clutch	1
18	Input Worm Gear	1
19	Ball Bearing*	2
20	Disc Spring*	6
21	Spring Spacer*	2
22	Torque Switch Spacer*	1
23	Worm Spacer*	2
24	Ball Bearing	1
26	Thrust Washer	2
27	Thrust Bearing	1
30	Spring Sleeve*	1
31	Input Worm Shaft	1
32	Torque Nut	1
33	Ball Bearing	1
34	Handwheel Cap	1
37	Handwheel Input Shaft	1
40	Bearing Stop*	1
41	Handwheel	1
44	Declutch Shaft	1
45	Declutch Lever	1
46	Declutch Fork Assembly	1
47	Declutch Return Spring	1
48	Dowel Pin	1
50	Declutch Latch – Right	1
51	Declutch Latch – Left	1
52	Ball Bearing	2
53	Pinion Gear	1
54	Motor Pinion Gear	1

Piece #	Description	Qty
55	Retaining Washer	
56	Hex Head Cap Screw	4
57	Lockwasher	4
58	Mechanical Stop (Set Screw)	2
59	Set Screw	2
61	Hex Head Cap Screw	4
62	Lockwasher	4
63	Hex Head Cap Screw	2
64	Lockwasher	2
65	Hex Head Cap Screw	2
66	Lockwasher	2
67	Hex Head Cap Screw	6
68	Lockwasher	6
70	Roll Pin – HW Input Shaft	1
72	Hex Head Cap Screw	1
73	Lockwasher	1
79	Fillister HD Machine Screw	1
80	Lockwasher	2
81	Terminal Bracket	1
82	Fillister HD Machine Screw	2
83	Lockwasher Internal Tooth	2
84	Pipe Plug	1
85	Pipe Plug	1
86	Hex Head Screw	4
94	Roll Pin*	1
96	Groove Pin*	1
97	Fillister HD Machine Screw.	2
98	Lockwasher Internal Tooth	2
99	Flat Washer*	1
100	Flexloc Nut*	1
106	Dial Window	1
108	Dial Window Retaining Plate	1
109	Dial Window Gasket	1
110	Terminal Strip	1
111	Press-on Retaining Clip	15
112	Roll Pin - Handwheel	1
113	Retaining Ring	1
114	Retaining Ring	1
118	Key*	1
120	Heater	1
121	Roll Pin – Declutch Handle	1
123	Roll Pin – Declutch Shaft	1
124	Roll Pin – Input Shaft	1

Table 8.1 – LY 1001 Parts List (continued)

Piece #	Description	Qty
126	Roll Pin	1
127	O-Ring – Motor	1
128	Quad Ring	1
129	O-Ring (3 mm) – Drive Sleeve	1
130	Cover Seal	1
131	Housing Seal	1
132	O-Ring – Conduit Adapter	1
134	Quad Ring – Handwheel Shaft	1
135	O-Ring – Disc Spring Cap	1
137	Handwheel Cap Gasket	1
138	O-Ring – Declutch Handle	1
139	Unit Nameplate	1
140	Drive Screw – Nameplate	4
141	Grounding Lug	1
142	Hex Head Cap Screw	2
143	Lockwasher	2
144	Pipe Plug	2
145	O-Ring – Window	1
146	Dial	1
147	Fillister HD Machine Screw	1
148	Lockwasher Internal Tooth	1

* Worm Shaft Assembly Component

Piece #	Description	Qty
153	Spring Spacer*	1
154	Compression Spring	2
155	Handwheel Washer	2
156	Spacer – Worm Shaft	1
59	Set Screw	2
157	Washer*	1
165	Retaining Ring – Torque Nut	1
169	Capacitor Bracket	1
170	Fillister HD Machine Screw	1
171	Lockwasher Internal Tooth	1
180	Declutch Lever Plate	1
181	Drive Screws - Handle	2
182	Cheater Bar Warning Label	1
183	Drive Screws	2
184	Retaining Drive Rings	2
185	Key	1
186	Warning Label – Cover	1
187	Washer	1
188	Quad ring – Handwheel Shaft	1
189	Oil Seal – Motor Shaft	1

Table 8.2 – LY 2001/3001 Parts List

Piece #	Description	Qty
1	Housing	1
2	Top Plate	1
3	Control Cover	1
4	Conduit Adapter	1
5	Bearing Cap	1
6	Motor	1
7	Limit Switch Assembly	1
8	Torque Switch Assembly	1
9	Terminal Strip	2
10	Drive Sleeve and Gear	1
11	Capacitor	Varies
12	Capacitor Bracket	1
13	Clutch Sleeve	1
14	Worm Shaft*	1
15	Worm*	1
16	Handwheel Clutch (Lug Adapter)	1
17	Compression Spring	1
18	Input Worm Gear	1
19	Ball Bearing*	2
20	Disc Spring*	6
21	Spring Washer*	1
22	Bearing Spacer*	1
23	Worm Spacer*	1

Piece #	Description	Qty
24	Ball Bearing - Input	1
25	Lug Adapter	1
26	Thrust Washer	2
27	Thrust Bearing	2
28	Stop Pin	2
29	Spring Pack Shim*	1
30	Limit Sleeve*	1
31	Input Worm Shaft	1
32	Torque Nut	1
33	Ball Bearing	1
34	Spur Gear Cover	1
35	Handwheel Gear	1
36	Handwheel Pinion and Idler	1
37	Handwheel Input Shaft	1
38	Handwheel Input Shaft	1
39	Bushing	3
40	Bushing	1
41	Handwheel	1
42	Idler Shaft	1
43	Handwheel Pinion and Idler	1
44	Declutch Shaft	1
45	Declutch Lever	1
46	Declutch Fork Assembly	1

Table 8.2 – LY 2001/3001 Parts List (continued)

Piece #	Description	Qty
47	Declutch Lever Return Spring	1
48	Dowel Pin	1
49	Compression Spring	2
50	Declutch Latch – Right	1
51	Declutch Latch – Left	1
52	Ball Bearing	2
53	Worm Shaft Gear	1
54	Motor Pinion Gear	1
55	Spring Sleeve*	2
56	Hex Head Cap Screw	4
57	Lockwasher	4
58	Full-Threaded Hex Head Cap Screw	2
59	Locking Nut (Jam Nut)	2
60	Thread-Seal	2
61	Hex Head Cap Screw	4
62	Lockwasher	4
63	Hex Head Cap Screw	2
64	Lockwasher	2
65	Hex Head Cap Screw	2
66	Lockwasher	2
67	Hex Head Cap Screw	8
68	Lockwasher	8
69	Handwheel Cap Plate	1
70	Fillister HD Machine Screw	1
71	Lockwasher	1
72	Hex Head Cap Screw	1
73	Lockwasher	1
74	Fillister HD Machine Screw	Varies
75	Lockwasher	Varies
76	Hex Nut	Varies
77	Fillister HD Machine Screw	Varies
78	Lockwasher Internal Tooth	1
79	Fillister HD Machine Screw	2
80	Lockwasher Internal Tooth	2
81	Terminal Bracket	1
82	Fillister HD Machine Screw	2
83	Lockwasher Internal Tooth	2
84	Pipe Plug	2
86	Hex Head Cap Screw	4
88	Hex Head Cap Screw	2
89	Lockwasher	2
90	Worm Drive Clamp	Varies
94	Socket Head Cap Screw	2
95	Lockwasher	2
96	Input Gear – Dowel Pin	2
97	Fillister HD Machine Screw	2
98	Lockwasher Internal Tooth	2
99	Bearing Locknut*	1
100	Stop Window*	1
106	Dial Window	1
107	Dial Window Gasket	1

Piece #	Description	Qty
108	Dial Window Retaining Plate	1
109	Retaining Drive Ring Internal	1
110	Terminal Strip	1
111	Press-on Retaining Clip	15
112	Roll Pin – Handwheel	1
113	Retaining Ring	1
114	Retaining Ring	1
115	Retaining Ring	1
116	Retainer Washer	1
117	Roll Pin (Spring)*	1
118	Key*	1
119	Retaining Ring	1
120	Heater Bracket Assembly	1
121	Roll Pin – Declutch Lever	1
122	Roll Pin – Declutch Shaft	1
123	Roll Pin – Declutch Shaft	1
124	Key – Input Shaft	1
125	Retaining Ring – Motor Pinion	1
126	Key – Motor Pinion	1
127	O-Ring – Motor	1
128	Quad Ring – Drive Sleeve	1
129	O-Ring – Drive Sleeve	1
130	Cover Seal	1
131	Housing Seal	1
132	O-Ring – Conduit Adapter	1
134	O-Ring – Handwheel Shaft	1
135	O-Ring – Bearing Cap	1
136	Lip Seal	1
137	Gear Cover Gasket	1
138	O-Ring – Declutch	1
139	Unit Nameplate	1
140	Drive Screw	4
141	Grounding Lug	1
142	Hex Head Cap Screw	2
143	Lockwasher	2
144	Pipe Plug	2
145	O-Ring – Window	1
146	Handwheel Label	1
147	Fillister HD Machine Screw	1
148	Lockwasher Internal Tooth	1
157	Spacer	4
174	Roll Pin	2
180	Declutch Lever Plate	1
181	Drive Screw	2
182	Cheater Bar Warning Label	1
183	Drive Screw	2
184	Retaining Washer	1
186	Warning Label	1
192	Gear Cover Gasket	1
193	Dial	1

* Worm Shaft Assembly Component

9

How to Order Parts

To order parts or obtain further information for your Limitorque LY valve actuators, contact your local Limitorque distributor sales office, or:

Flowserve Limitorque
5114 Woodall Road
Lynchburg, VA 24502
Telephone: 434-528-4400
Fax 434-845-9736

All inquiries or orders must be accompanied by the following information, which is located on the nameplate:

1. Operator size
2. Order number
3. Serial number

10

Regulatory Information

Declaration of Conformity

Application of Council Directive(s)

89/336/EEC; EMC Directive

98/37/EEC; Machinery Directive

Standard(s) to which Conformity is Declared

Machinery; EN 60204 EMC

- Emissions; EN 50081-1and 2, EN 55011, CFR 47
- Immunity; EN 50082-1and 2, IEC 801-3 and IEC 801-6 ESD; IEC 801-2
- EFT/Bursts; IEC 801-4
- Surge Immunity; IEC 801-5, ANSI/IEEE C62.41 Mains (power)
- Harmonics; MIL-STD-462, Method CSO1 and CSO2

Manufacturer's Name

Limitorque, a Flowserve Company

Manufacturer's Address

5114 Woodall Road

Lynchburg, VA 24502

Importer's Name

Limitorque, a Flowserve Company

Importer's Address

Abex Road

Newbury

Berkshire, RG14 5EY

England

Type and Description of Equipment

Valve Actuators

Model Number

LY Series

Note

Tested with Limitorque products only

I, the undersigned, hereby declare that the equipment specified above conforms to the above Directive(s) and Standard(s). List as follows:



(Signature)

Barry Morse
(Full Name)

Internal Sales Manager
(Title)

Newbury, England
(Place)

November 1, 1999
(Date)



This page intentionally left blank.



Flowserve Corporation Flow Control

United States

Flowserve Limatorque
5114 Woodall Road
P.O. Box 11318
Lynchburg, VA 24506-1318
Phone: 434-528-4400
Facsimile: 434-845-9736

England

Flowserve Limatorque
Euro House
Abex Road
Newbury
Berkshire, RG14 5EY
United Kingdom
Phone: 44-1-635-46999
Facsimile: 44-1-635-36034

Japan

Limatorque – Nippon Gear Co., Ltd.
NOF Bldg. 9th Floor
1-11-11, Kita-Saiwai, Nishi-Ku
Yokohama (220-0004)
Japan
Phone: 81-45-326-2065
Facsimile: 81-45-320-5962

Singapore

Flowserve Limatorque
12, Tuas Avenue 20
Singapore 638824
Phone: 65-6868-4628
Facsimile: 65-6862-4940

China

Limatorque Beijing, Pte., Ltd.
RM A1/A2
22/F, East Area, Hanwei Plaza
No. 7 Guanghua Road, Chaoyang District
Beijing 100004, Peoples Republic of China
Phone: 86-10-5921-0606
Facsimile: 86-10-6561-2702

India

Flowserve Limatorque, Ltd.
Plot No 4
Export Promotional Industrial Park
Whitefield, Bangalore 560066
India
Phone: 91-80-40146200
Facsimile: 91-80-28410286

FCD LMENIM1501-00 Printed in USA. (Replaces LMAIM1501)

To find your local Flowserve representative:

For more information about Flowserve Corporation, visit
www.flowserve.com or call USA 1 800 225 6989

Flowserve Corporation has established industry leadership in the design and manufacture of its products. When properly selected, this Flowserve product is designed to perform its intended function safely during its useful life. However, the purchaser or user of Flowserve products should be aware that Flowserve products might be used in numerous applications under a wide variety of industrial service conditions. Although Flowserve can (and often does) provide general guidelines, it cannot provide specific data and warnings for all possible applications. The purchaser/user must therefore assume the ultimate responsibility for the proper sizing and selection, installation, operation, and maintenance of Flowserve products. The purchaser/user should read and understand the Installation Operation Maintenance (IOM) instructions included with the product, and train its employees and contractors in the safe use of Flowserve products in connection with the specific application.

While the information and specifications contained in this literature are believed to be accurate, they are supplied for informative purposes only and should not be considered certified or as a guarantee of satisfactory results by reliance thereon. Nothing contained herein is to be construed as a warranty or guarantee, express or implied, regarding any matter with respect to this product. Because Flowserve is continually improving and upgrading its product design, the specifications, dimensions and information contained herein are subject to change without notice. Should any question arise concerning these provisions, the purchaser/user should contact Flowserve Corporation at any one of its worldwide operations or offices.

© 2011 Flowserve Corporation, Irving, Texas, USA. Flowserve is a registered trademark of Flowserve Corporation.