



Goulds 3409

Medium Capacity, Single Stage,
Double Suction Pump



ITT

ENGINEERED FOR LIFE

3409

Double Suction Pumps Designed for a Wide Range of Industrial, Marine and Power Generation Services

- Capacities to 12,000 GPM (2725 m³/h)
- Heads to 850 feet (259 m)
- Temperatures to 250° F (120° C)
- Working Pressures to 400 PSIG (2758 kPa)

Design Features

- **Horizontally Split Casing** - In-line suction and discharge nozzles in lower half casing for ease of inspection/maintenance.
- **Double Suction Impeller** - Assures Hydraulic Axial Balance for lower thrust bearing loads, longer pump life, and low maintenance.
- **Wear Rings** - Easily replaceable wear rings renew running clearances, protect against impeller, casing wear. Overall cost of operation is minimized.
- **Sealing Flexibility** - Choice of packing or wide range of mechanical seals.
- **Installation Versatility** - Horizontal or vertical mounting, clockwise or counter clockwise rotation.
- **Material Flexibility** - Available in a wide variety of metals from cast iron to stainless steels.



Services

- **Process** - Quench water, stripper bottoms, reboiler circulation, cooling tower
- **Pulp & Paper** - Primary and secondary cleaner, filtrate, mill water supply shower, fan pump
- **Primary Metals**- Cooling Water, Quench and Leaching
- **Municipal** - High Lift, Low Lift, Wash Water, Waste Water, Raw Water
- **Power Generation** - Cooling Tower, Component Cooling, Service Water, Ash Sluicing, Heater Drain
- **Marine** - Bilge and Ballast, Cargo, Cooling Water, Fire Pump
- **General** - River Water, Brine, Sea Water

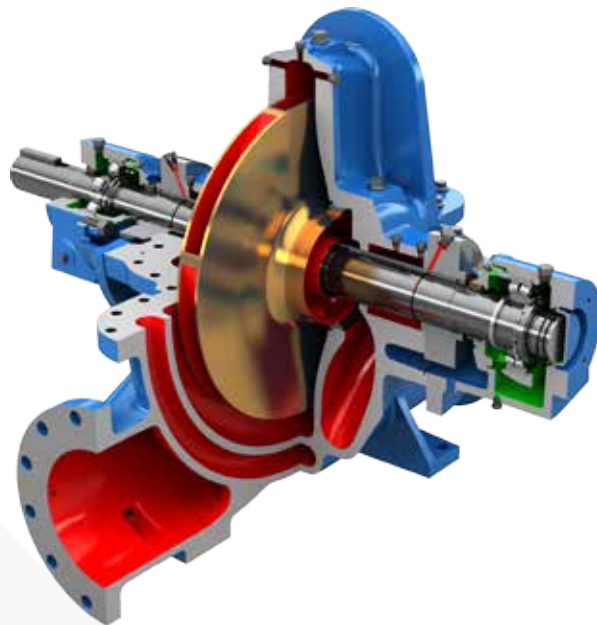

Sectional View

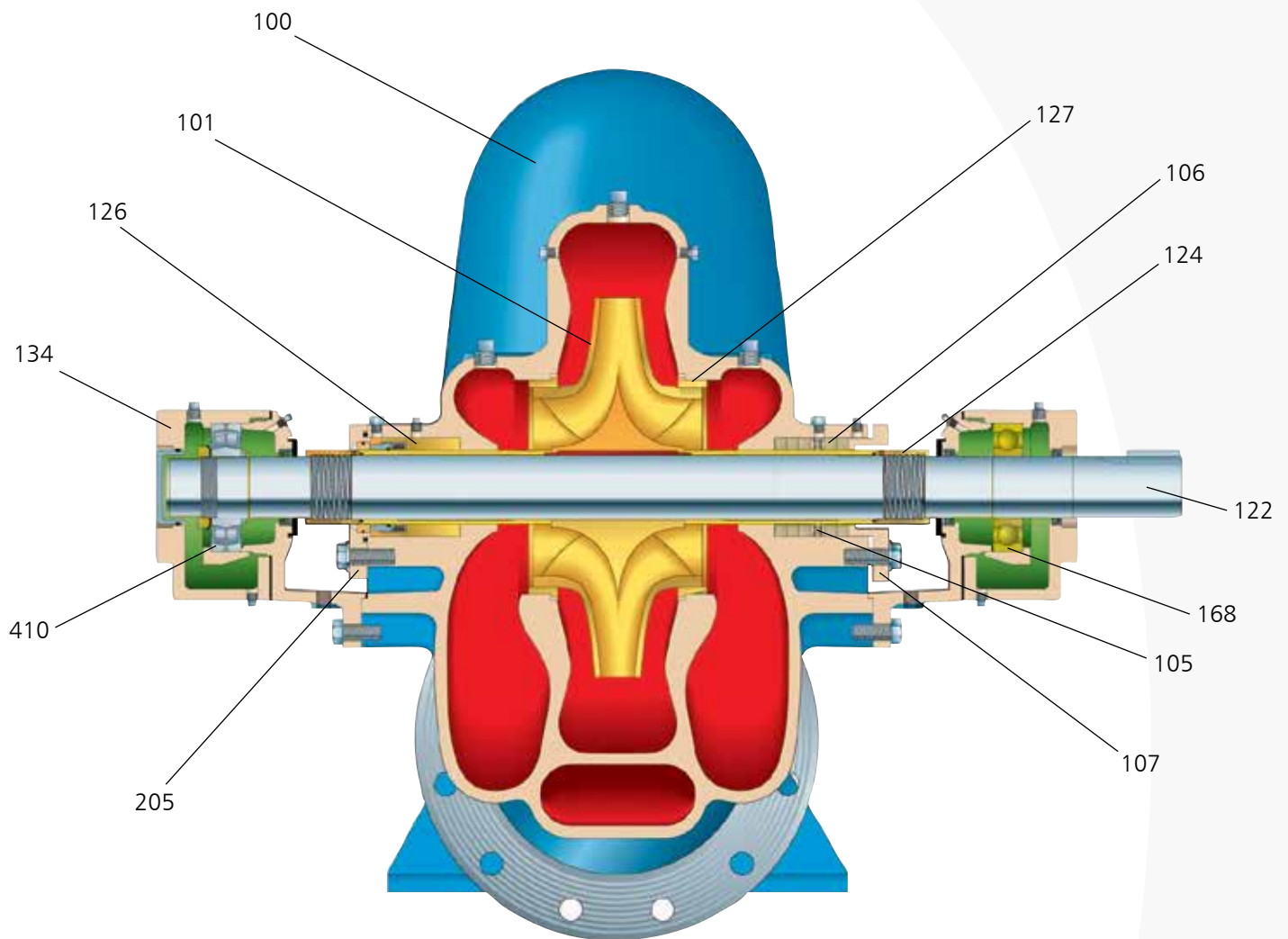

Parts List and Materials of Construction

Item Number	Part Name	Material			
		Bronze Fitted	All Iron	316SS Fitted	All 316SS
100	Casing		Cast Iron		316SS
101	Impeller	Bronze	Cast Iron	316SS	
105	Lantern Ring	Teflon			
106	Packing	Graphite Impregnated Yarn			
107	Packing Gland	Bronze	Cast Iron	316SS	
250	Mechanical Seal Gland		Cast Iron		316SS
122	Shaft	Carbon Steel ¹			
124	Shaft Sleeve Nut	Bronze	Cast Iron	Nitronic 60	
126	Shaft Sleeve ²	Bronze	Cast Iron	316SS	
127	Casing Wear Ring	Bronze	Cast Iron	Nitronic 60	
134	Bearing Housing	Cast Iron			
142	Impeller Wear Ring (optional on 3409)	Bronze	Cast Iron	316SS	
168 & 410	Bearings	Steel (Anti-Friction)			

3409 Medium Capacity, Single Stage, Double Suction Pumps

Heavy Duty Design Features for a Wide Range of Heavy Duty Industrial, Marine and Power Generation Services

RENEWABLE CASE WEAR RINGS

Permits easy maintenance of proper running clearances. Locked in lower half casing to prevent rotation.

HEAVY DUTY SHAFT

Designed to reduce deflection. Renewable shaft sleeves fully protect shaft from pumpage. Threaded sections removed from stress areas.

HIGH THRUST CAPABILITY

Spherical roller bearings handle unexpected thrusts. Secured with locknut and washer.

LARGE INLET AREAS

Assures smooth flow to impeller inlet for efficient, quiet operation.

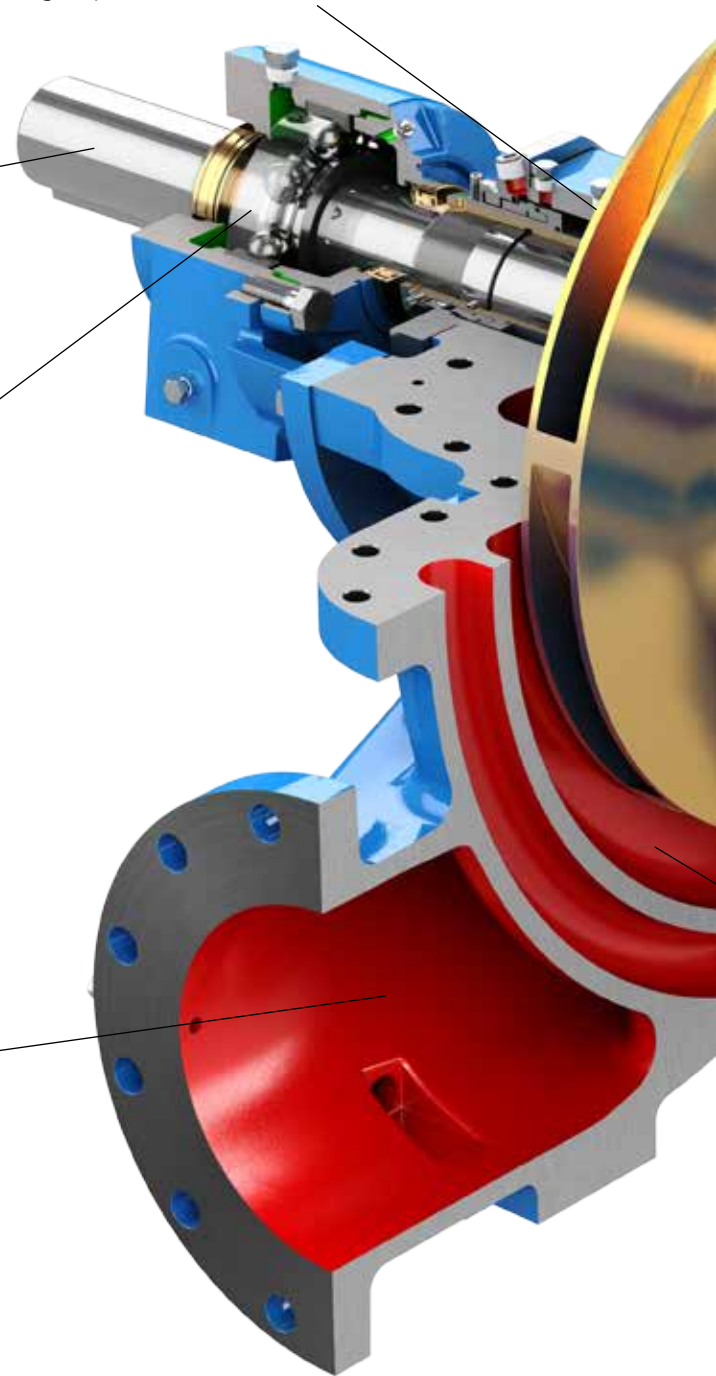



HEAVY DUTY CASING

Casing walls designed to withstand pressure extremes. Rugged design resists external forces and vibrations. Both suction and discharge connections in lower half casing. Removal of upper half casing permits inspection, maintenance and removal of the complete rotating element without disturbing piping or driver.

RENEWABLE IMPELLER WEAR RINGS AVAILABLE

A must for proper maintenance of running clearances. Rings are mechanically locked onto impeller hubs.

POSITIVE LIQUID SEALING

Gaskets between impeller and sleeves, and O-rings between sleeves and sleeve nuts protect shaft from pumpage or confined corrosion attack.

LABYRINTH BEARING PROTECTION

Labyrinth bearing isolators significantly reduce the chance for bearing contamination and greatly improve mean time between failures.

DOUBLE SUCTION IMPELLER

Minimizes axial thrust. Highly efficient for smooth, vibration-free operation.

DUAL VOLUTE CASING DESIGN

Dual volutes having cutwaters 180° apart provide opposing radial forces reducing radial loads on bearings and minimizing shaft deflection. Permits smooth, trouble-free operation over wide range of flow rates.

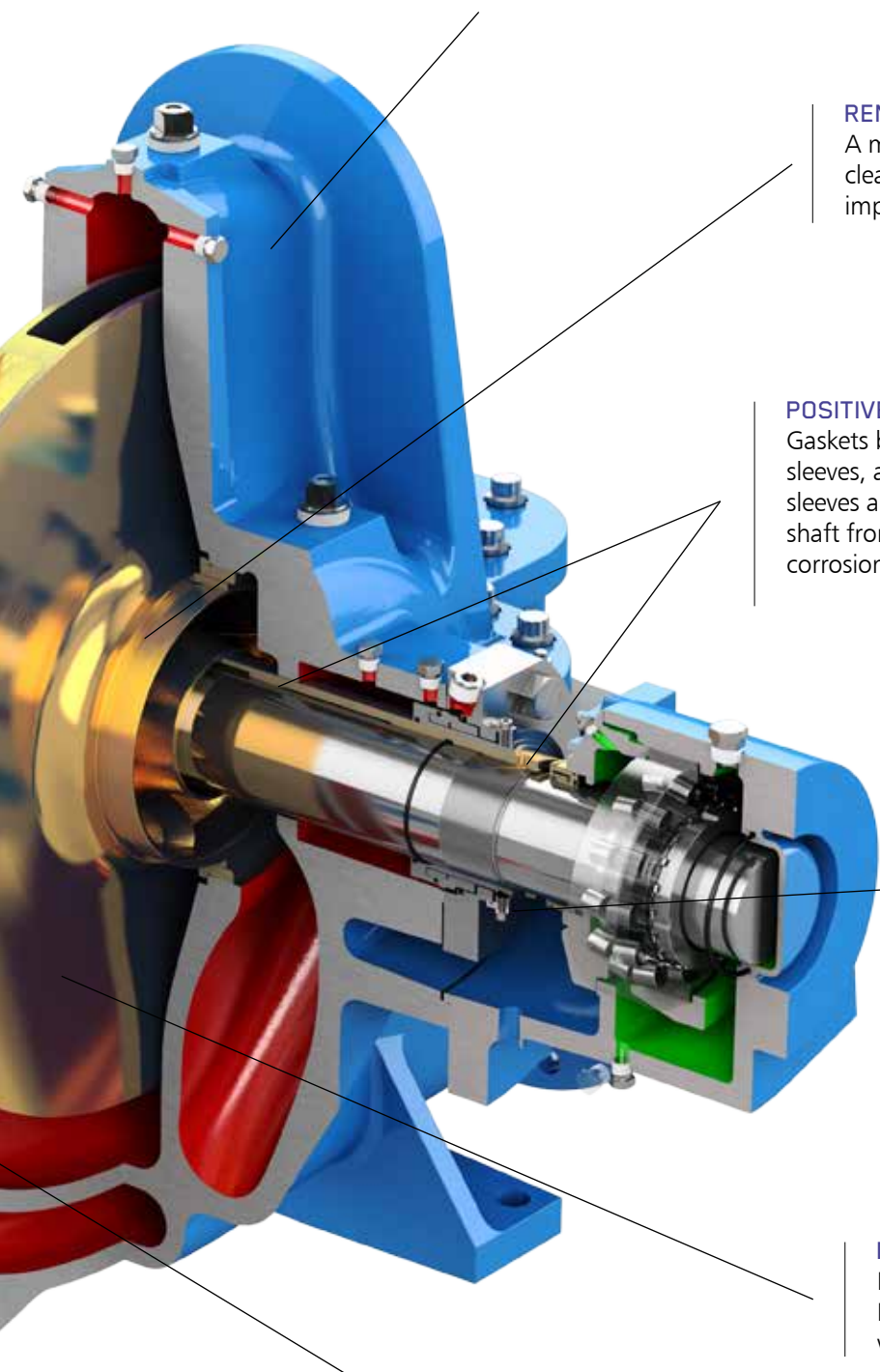

Hydraulic Coverage

MODEL 3409 – 1785 RPM

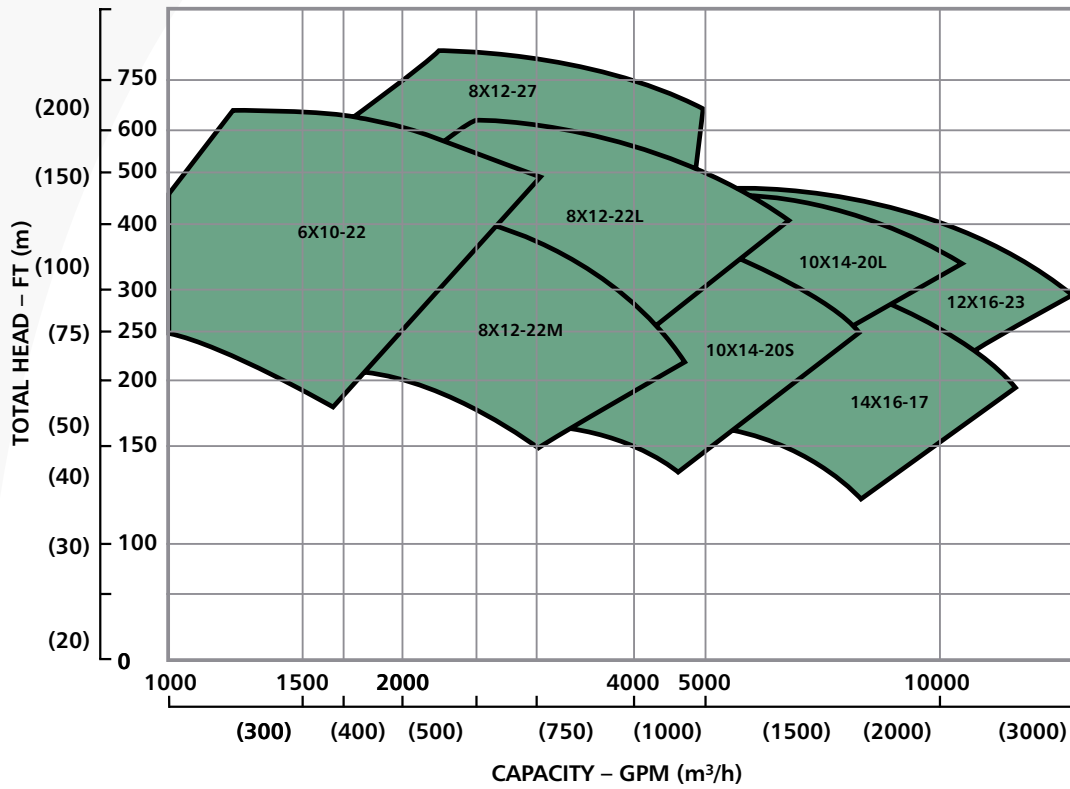

MODEL 3409 – 1180/880 RPM

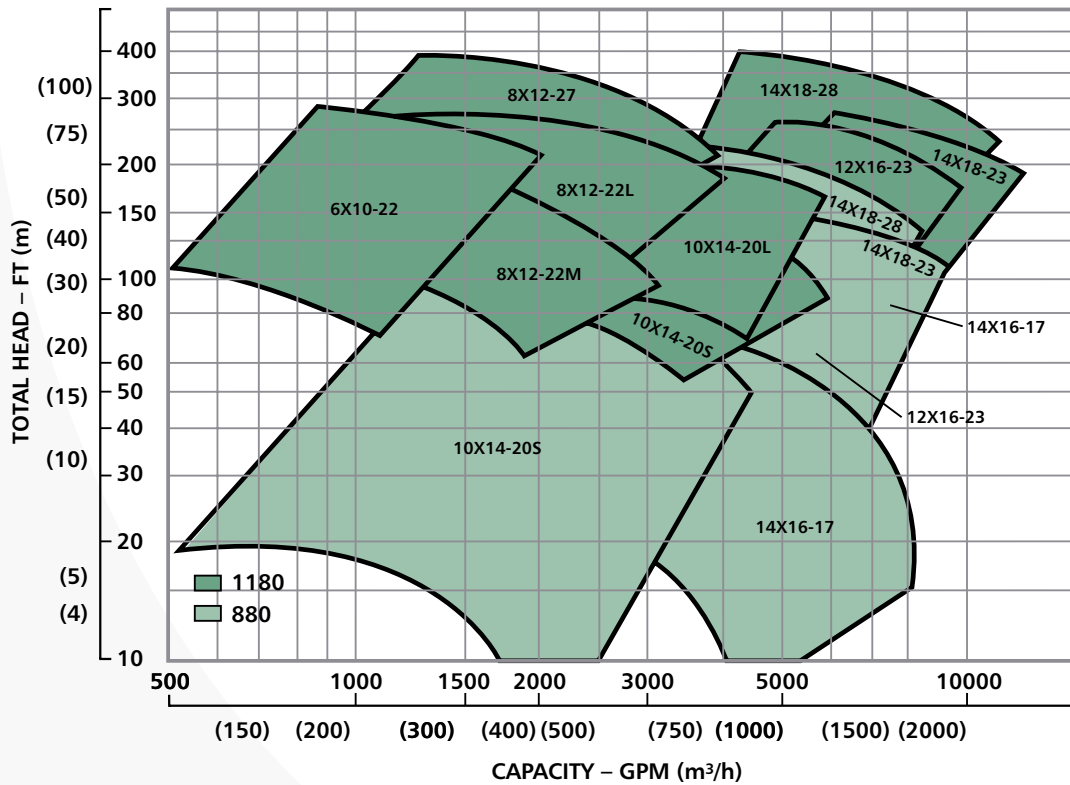

Dimensions and Weights

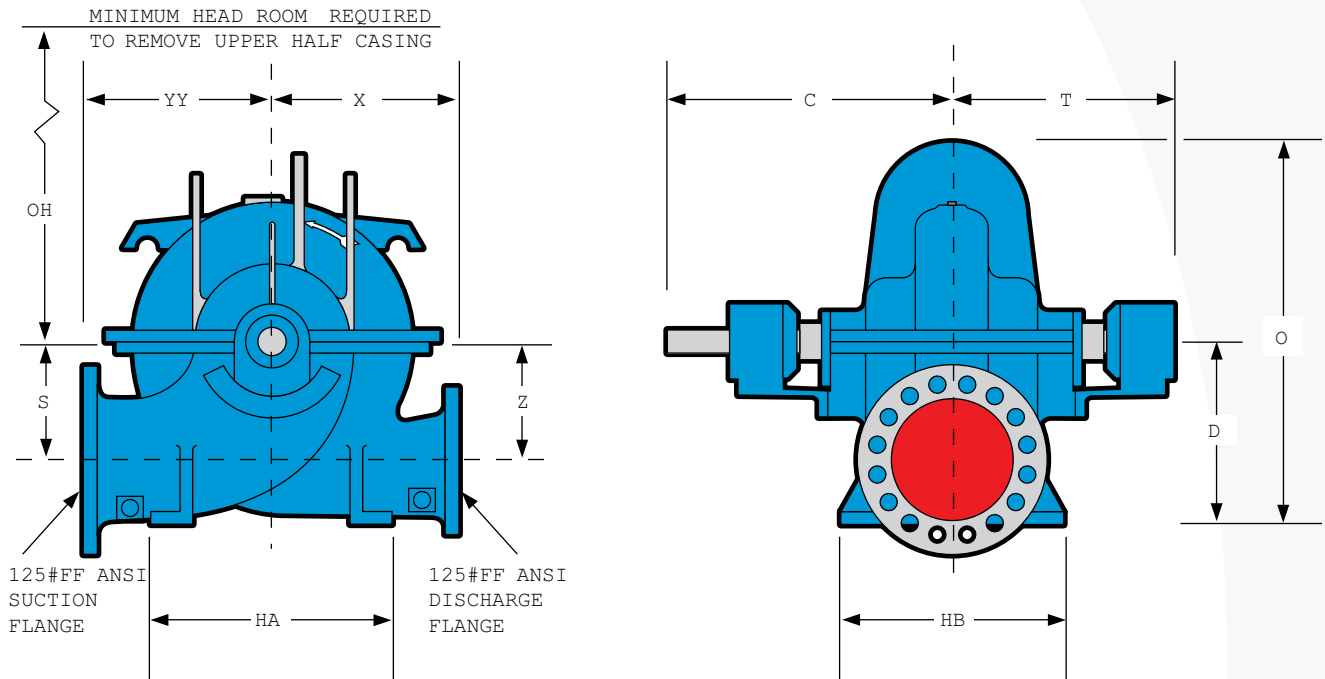

Frame Group	Pump Size	C	T	D	OH	O	S & Z	X		HA	HB	Weight Lbs. (kg)	
37.9 (962) S	6X10-22	28.3 (718)	21.8 (552)	19 (483)	30.4 (772)	12 (305)	19 (483)	20	24 (610)	18 (457)	1545 (701)		
	8X12-22M				30.4 (772)						21 (533)	1920 (871)	
	8X12-22L				31.4 (798)						21 (533)	1930 (875)	
43.9 (1115) 42.8 (1086) M	8X12-27	30.5 (775)	23.8 (603)	21 (533)	36.4 (924)	14.2 (360)	23 (584)	24 (610)	24 (610)	24 (610)	2940 (1334)		
	10X14-20S				31.7 (804)						19 (483)	21 (533)	2000 (907)
	10X14-20L				23 (584)						25 (635)	25 (635)	2050 (930)
	12X16-23				37.4 (949)						18 (457)	24 (610)	2600 (1179)
	14X16-17				23.5 (597)						31.8 (806)	24 (610)	2860 (1297)
47.6 (1210) 56.8 (1441)	14X18-23	31.6 (802)	24.8 (629)	24 (610)	14 (356)	27 (686)	27 (686)	27 (711)	26 (660)	2940 (1334)			
	14X18-28			26 (660)						44.7 (1135)	28 (711)	28 (711)	3255 (1476)

Sizes 6X10-22, 8X12-22M, 8X12-22L are furnished with 250# FF discharge flange as standard.

Size 8X12-27 is furnished with 250# FF suction and discharge flange as standard.

All dimensions in inches (mm) and are not to be used for construction or installation purposes.

Standard rotation is right hand (CW). Optional rotation is left hand (CCW).

Steel casings will have 150#RF or 300#RF flanges.

Visit our website at
www.gouldspumps.com

Wherever you are, we're there too.

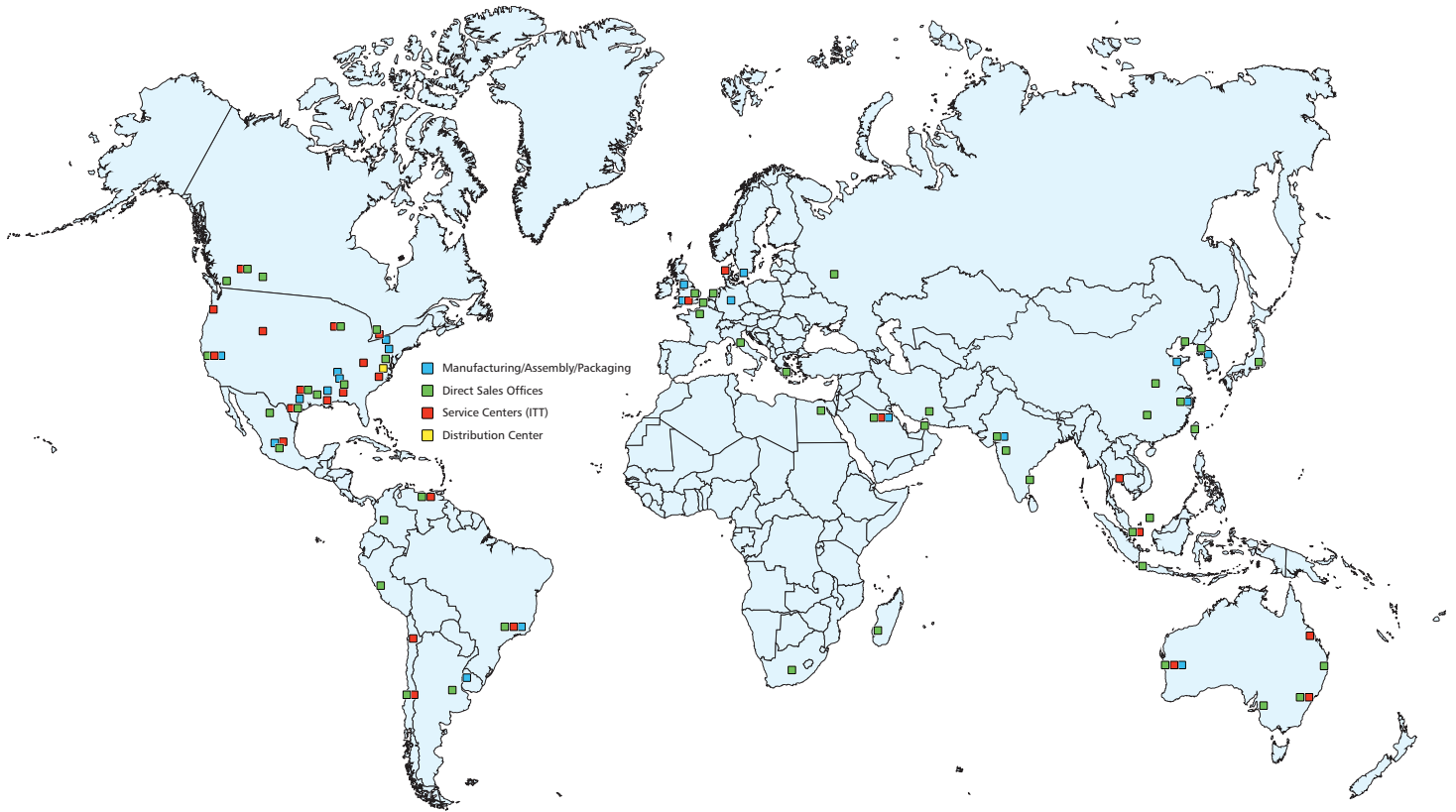

PRO services

Reliability has no quitting time.

Building on over 160 years of Goulds Pumps experience, PRO Services provides an array of services focused on reducing equipment total cost of ownership (TCO) and increasing plant output, including predictive monitoring, maintenance contracts, field service, engineered upgrades, inventory management, and overhauls for pumps and other rotating equipment.

Your Total Solution For Equipment Life Cycle Optimization

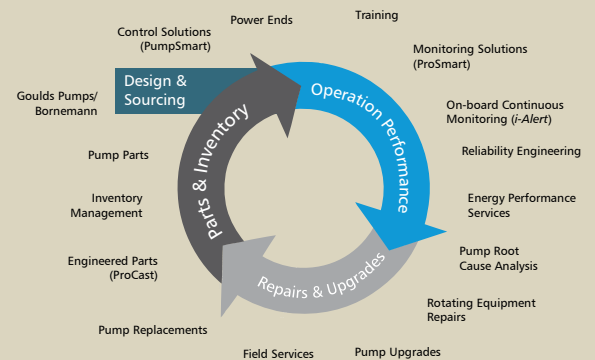

240 Fall Street
Seneca Falls, NY 13148
www.itt.com

© 2015 ITT Corporation, Inc.

B.3409.en-US.2016-06